

# IKA

designed for scientists

**EUROSTAR 20 digital**  
**EUROSTAR 40 digital**  
**EUROSTAR 60 digital**  
**EUROSTAR 100 digital**  
**EUROSTAR 20 high speed digital**  
**EUROSTAR 400 high torque digital**

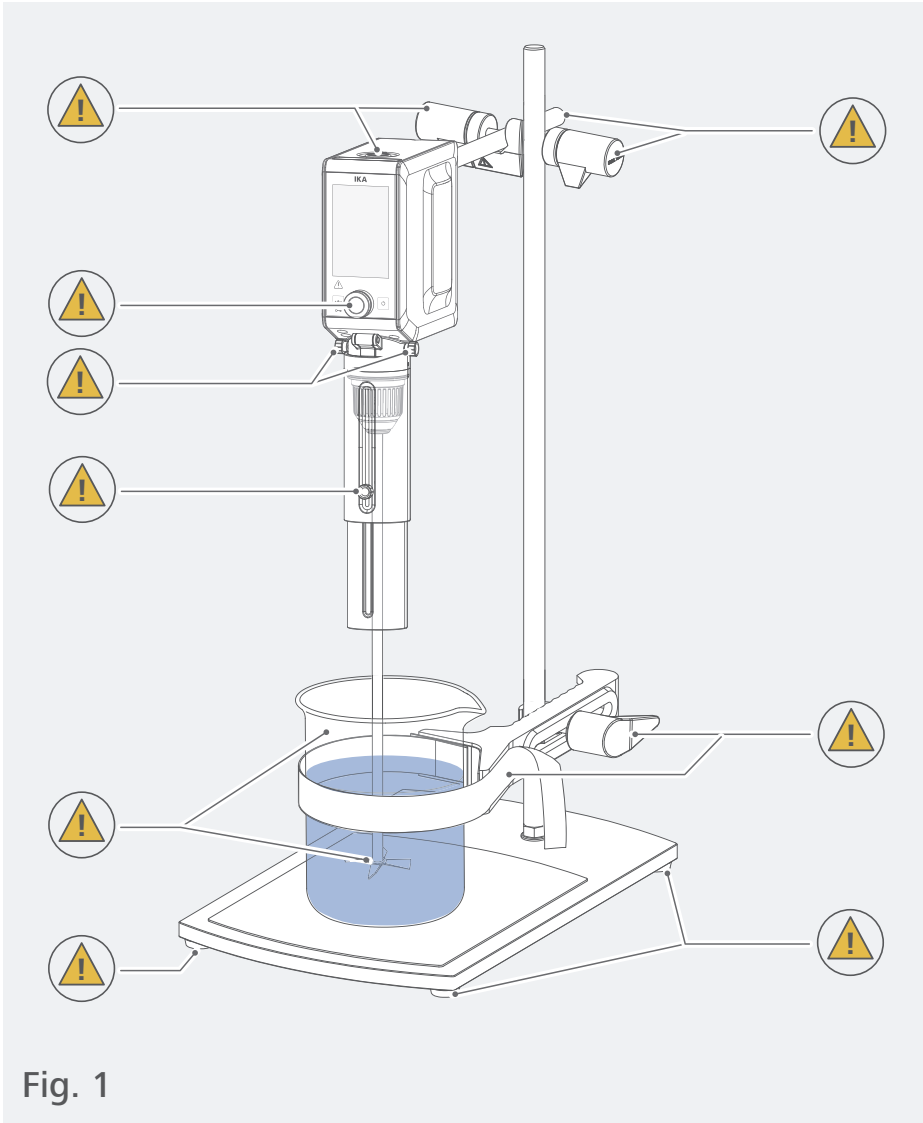

	EU Declaration of conformity .....	5
	Explication of warning symbols .....	6
	Safety instructions.....	7
	Intended use.....	10
	Unpacking .....	100
	Installation .....	101
	Operation .....	106
	Menu navigation and structure .....	110
	Technical Data .....	112



This user guide will inform you about the most important information and operations.  
You can download the complete operating instructions on our website.



Source language: German

## EU Declaration of conformity

We declare under our sole responsibility that this product corresponds to the directives 2014/35/EU and 2006/42/EC, 2014/30/EU and 2011/65/EU and conforms with the following standards or normative documents: EN 61010-1, EN 61010-2-051, EN 61326-1, EN 60529 and EN ISO 12100.

A copy of the complete declaration of conformity or further declarations of conformity can be requested.





## Explication of warning symbols

### /// Warning symbols



#### **Danger!**

Indicates an (extremely) hazardous situation, which, if not avoided, will result in death, serious injury.



#### **Warning!**

Indicates a hazardous situation, which, if not avoided, can result in death, serious injury.



#### **Caution!**

Indicates a potentially hazardous situation, which, if not avoided, can result in injury.



#### **Notice!**

Indicates practices which, if not avoided, can result in equipment damage.

### /// General Symbols

**A** — Position number



#### **Correct/Result!**

Shows the correct execution or the result of an action step.



#### **Wrong!**

Shows the incorrect execution of an action step.



#### **Note!**

Displays action steps that require particular attention to detail.



#### **Beep**

Shows action steps where audible beeps can be heard.



#### **Closed lock**

Indicates the status of "locked".



#### **Open lock**

Indicates the status of "Unlocked".

# Safety instructions



## /// General information

- › **Read the operating instructions completely before starting up and follow the safety instructions.**
- › Keep the operating instructions in a place where it can be accessed by everyone.
- › Ensure that only trained staff work with the device.
- › Follow the safety instructions, guidelines, occupational health and safety and accident prevention regulations.

### **Danger!**

- › Pay attention to the marked sites in Fig. 1.  
Beware of the risk of:
  - flammable materials
  - glass breakage as a result of mechanical stirring power.

### **Caution!**

- › Wear your personal protective equipment in accordance with the hazard category of the medium to be processed, there is a risk of:
  - splashing of liquids
  - projectile parts
  - body parts, hair, clothing and jewellery getting caught.
- › The device must only be used in a technically perfect condition.

## /// Device setup

### **Danger!**

- › The power switch of the IKA device must be accessed immediately, directly and without risk at any time. If installation or positioning cannot ensure this access at all times, an additional **EMERGENCY STOP** switch that can be easily accessed must be installed in the work area.

### **Warning!**

- › Ensure stable assembly. The vessel used for stirring must be secured.
- › Use stirring shaft protective equipment.

### **Notice!**

- › Set up the stand in a spacious area on an even, stable, clean, non-slip, dry and fireproof surface.
- › Avoid knocking and impacting on the lower end of the shaft and the chuck. Even minor, invisible damage can lead to imbalance and uneven shaft action.
- › You must ensure that the stirring element is securely clamped in the chuck.
- › All screw connections must be properly tightened.
- › The high torque developed by the device requires particular care in the choice of stand, cross sleeve and anti-rotation element for the agitating vessel.

## /// Working with the device

### ⊗ **Danger!**

- › Do not use the device in explosive atmospheres, it is not EX-protected.
- › With substances capable of forming an explosive mixture, appropriate safety measures must be applied, e.g. working under a fume hood.
- › To avoid body injury and property damage, observe the relevant safety and accident prevention measures when processing hazardous materials.
- › The device is not suitable for hand-held operation.
- › Do not touch rotating parts during operation.

### ⓘ **Warning!**

- › Pathogenic materials must only be processed in closed vessels under a suitable fume hood. If you have any questions, please contact IKA application support.
- › The operation of a free rotating shaft end is prohibited. Therefore, for safety reason, only insert through the stirring tool over the upper edge of housing at standstill.

### ⊗ **Caution!**

- › Make certain that the device is set at the lowest speed before commissioning; otherwise, the device will begin running at the speed set in last operation. Gradually increase the speed. Please observe the max. permitted speed for the stirring element. Never set higher speed.

### ⚠ **Notice!**

- › Covers or parts that can be removed from the device without tools must later be refitted to ensure safe operation. This will prevent the infiltration of foreign objects, liquids and other contaminants.
- › Imbalance of the output shaft, the chuck and in particular the stirring tools can lead to uncontrolled resonant vibrational behavior of the device and the whole assembly. Glass apparatus and stirrer containers can be damaged or shattered by this. It can cause injury to the operator, also can damage the rotating stirring tool. In this case exchange the stirring tool for one without imbalance or remedy the cause of the imbalance. If there is still imbalance, return it to the dealer or the manufacturer along with a description of the fault.
- › There may be electrostatic activity between the medium and the output shaft which could cause a direct danger.
- › Never operate the device with the stirrer tools rotating freely. Ensure that parts of the body, hair, jewelry or items of clothing cannot be trapped by the rotating parts.
- › Pay attention when setting the speed to any imbalance of the stirrer tools and possible spraying of the medium to be stirred.
- › Ensure that the stand does not start to move.
- › Only process media that will not react dangerously to the extra energy produced through processing. This also applies to any extra energy produced in other ways, e.g. through light irradiation.
- › Reduce the speed if:
  - the medium splashes out of the vessel because the speed is too high,
  - the device is not running smoothly,
  - the device begins to move around because of dynamic forces,
  - an error occurs.

### /// Accessories

- › Protect the device and accessories from bumping and impacting.
- › Check the device and accessories beforehand for damage each time when you use them. Do not use damaged components.
- › Safe operation is only guaranteed with the accessories described in the "Accessories" section.
- › Must disconnect the power before changing stirring element and fitting allowed accessories.

### /// Power supply / switching off the device

#### **Notice!**

- › If the device is operated too long in overload or if the ambient temperature is too high, the device switches off permanently.
- › The voltage stated on the type plate must correspond to the power voltage.
- › The socket for the power cord must be easily accessible.
- › Socket must be earthed (protective ground contact).
- › After an interruption in the power supply during a stirring process, the device does not restart automatically.
- › Disconnect the power plug before attaching or changing any accessories.
- › Disconnect the power plug before cleaning, maintenance and transportation of the unit.

### /// Maintenance

- › The device must only be opened by trained specialists, even during repair. The device must be unplugged from the power supply before opening. Live parts inside the device may still be live for some time after unplugging from the power supply.

### /// Disposal instructions

- › The device, accessories and packaging must be disposed of in accordance with local and national regulations.



## Intended use

### /// Use

For mixing/stirring liquids from low to high viscosities with various stirring tools.

**Intended use:** Stand device (chuck points down)

### /// Range of use

Indoor environments similar to that a laboratory of research, teaching, trade or industry.

The safety of the user cannot be guaranteed:

- › if the device is operated with accessories that are not supplied or recommended by the manufacturer.
- › if the device is operated improperly or contrary to the manufacture's specifications.
- › if the device or the printed circuit board are modified by third parties.



EUROSTAR 20 digital / 40 digital / 60 digital / 100 digital / 400 high torque digital

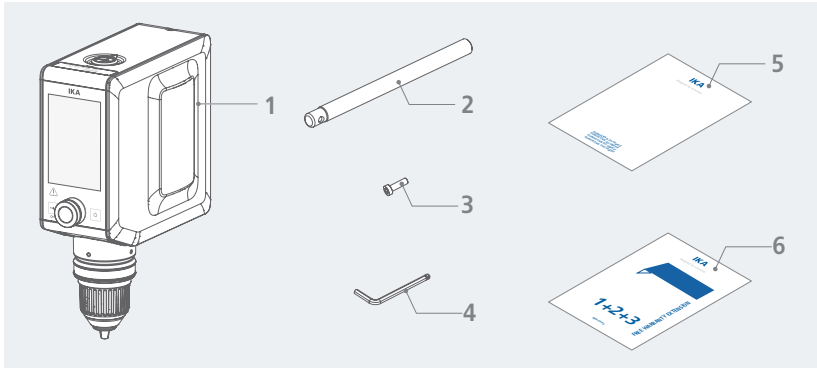

EUROSTAR 20 high speed digital

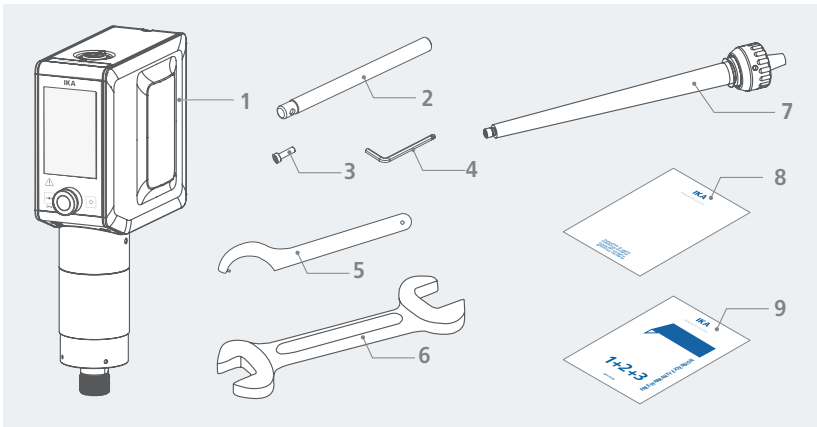

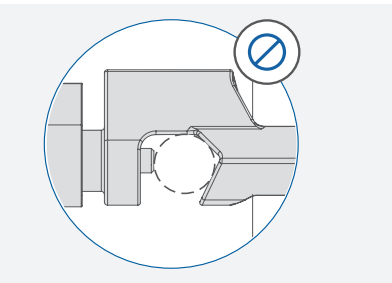
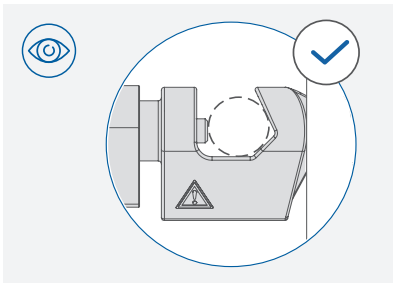
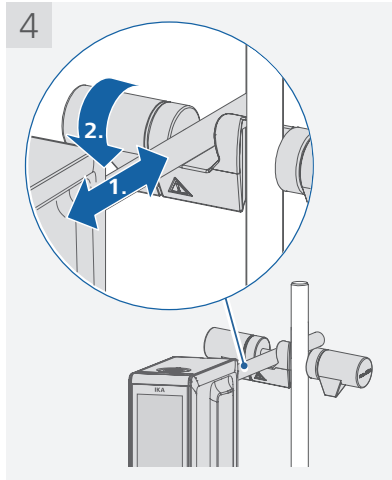
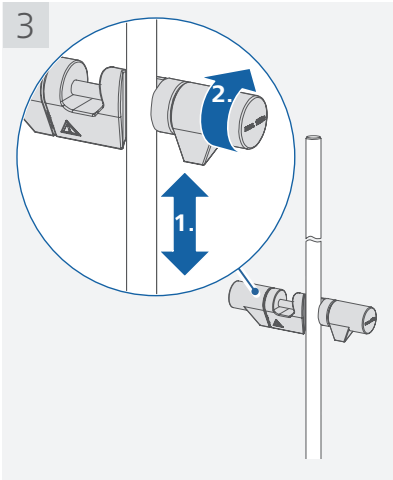
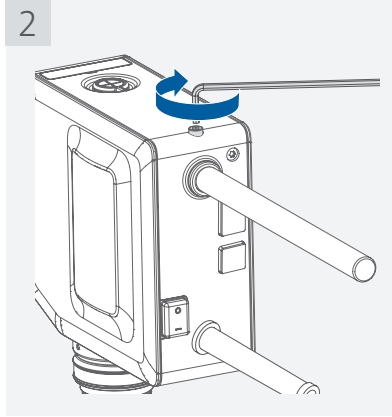
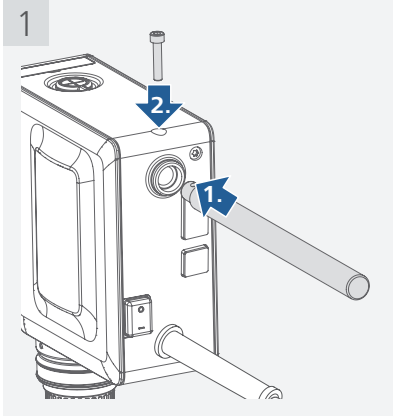

5 (a)

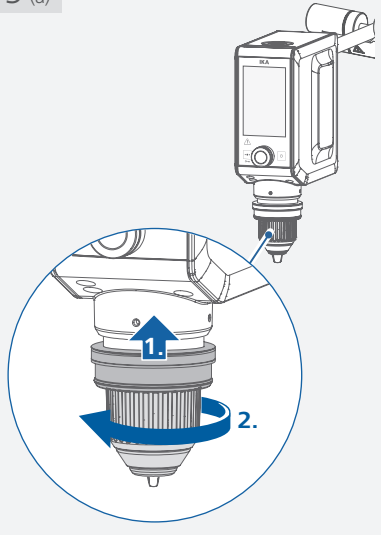

6 (a)

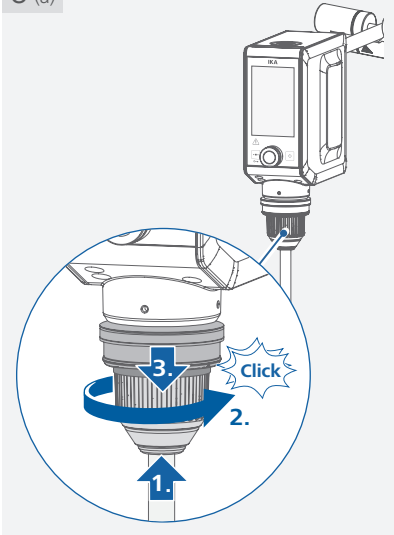

5 (b)

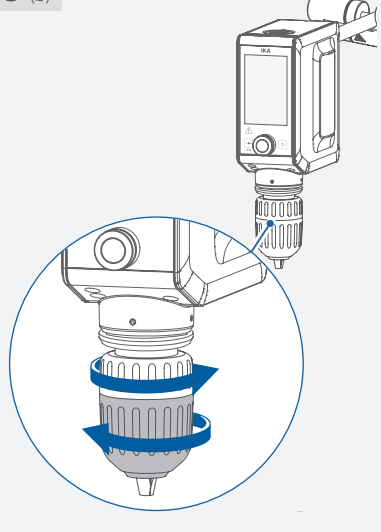

6 (b)

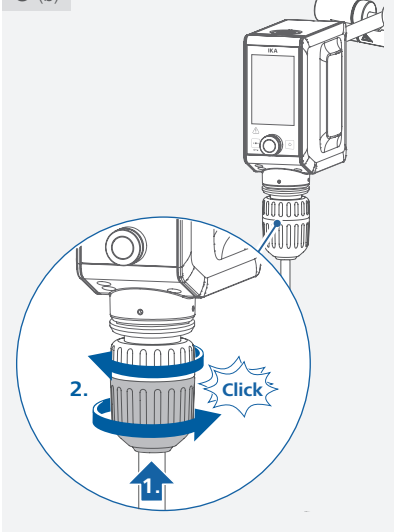

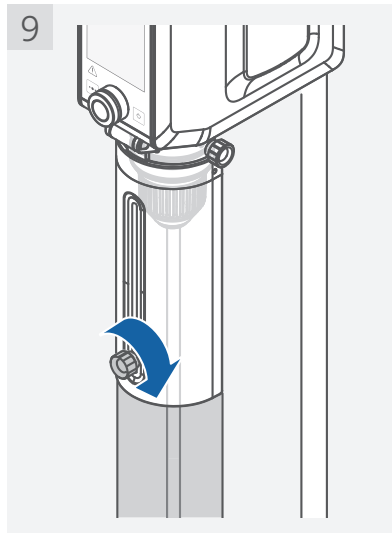
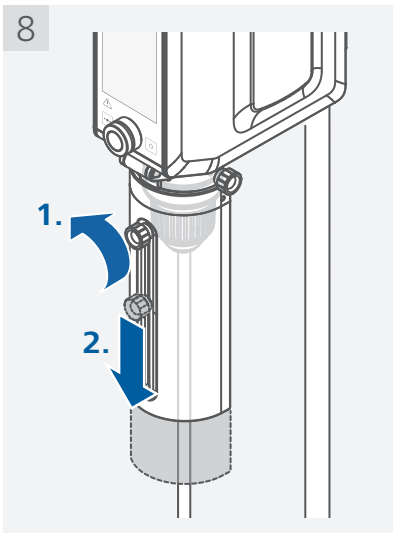
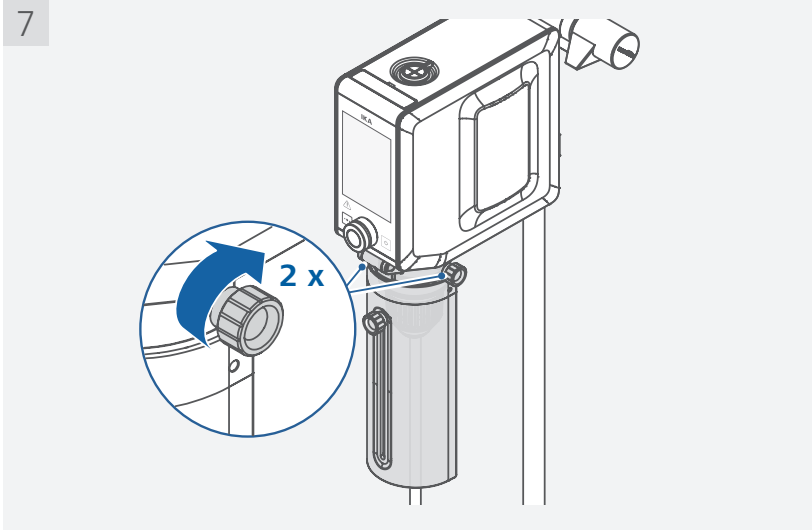

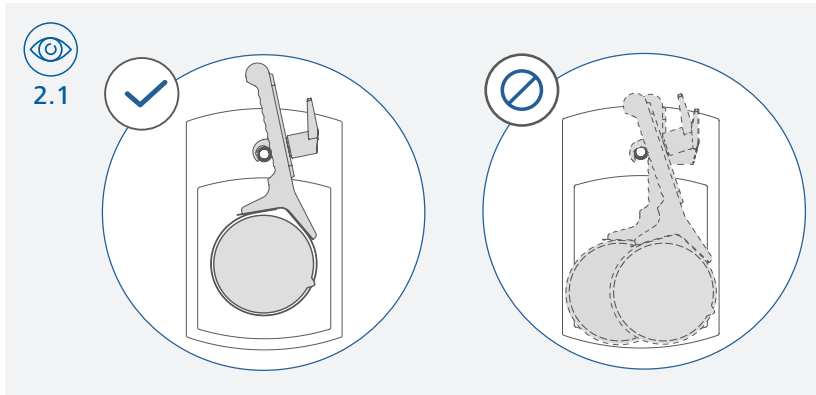
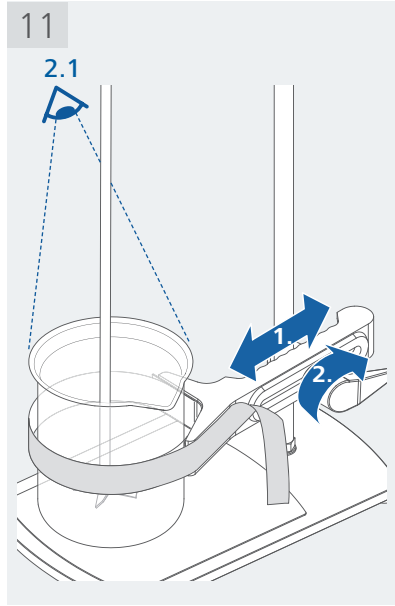
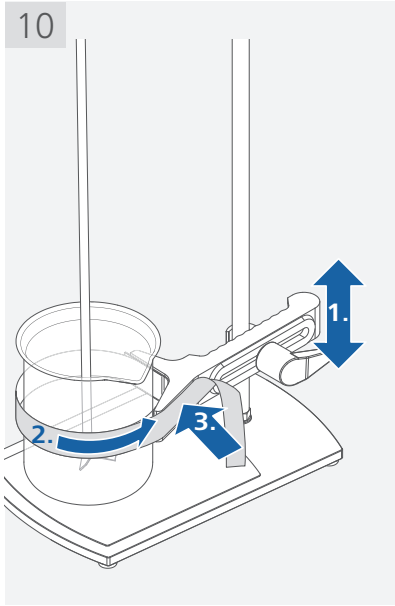

12

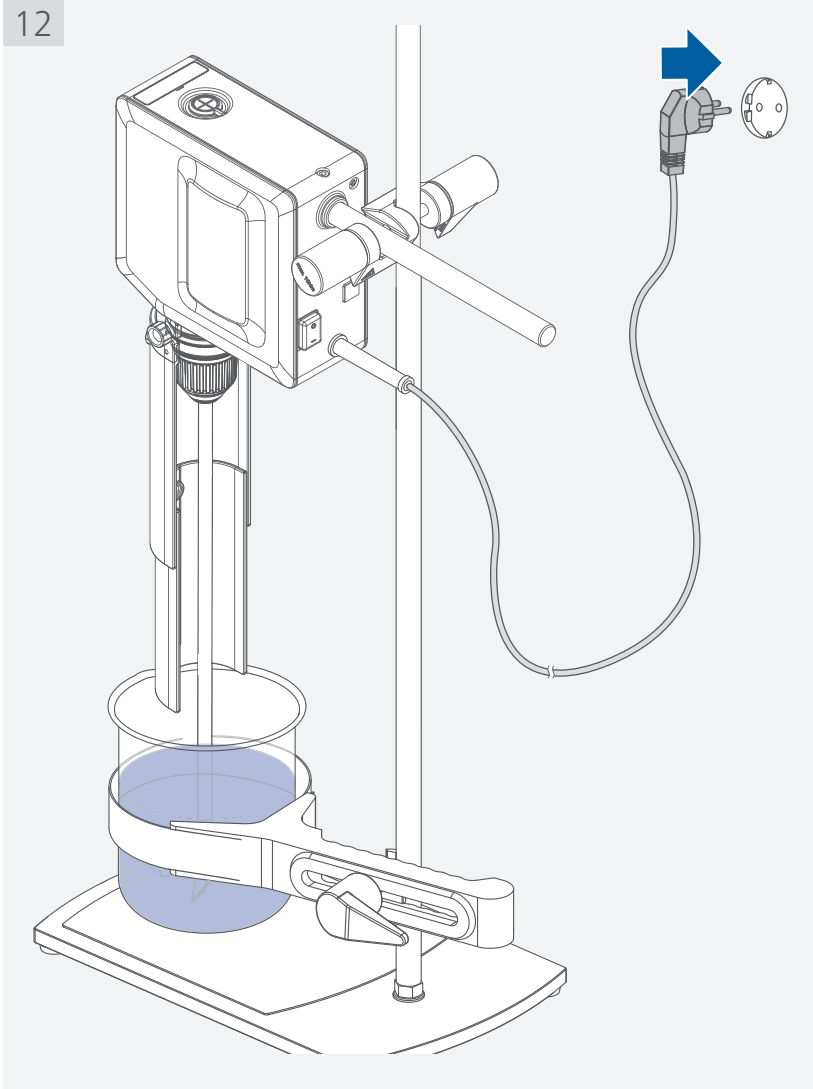



1

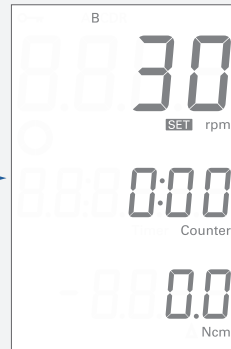
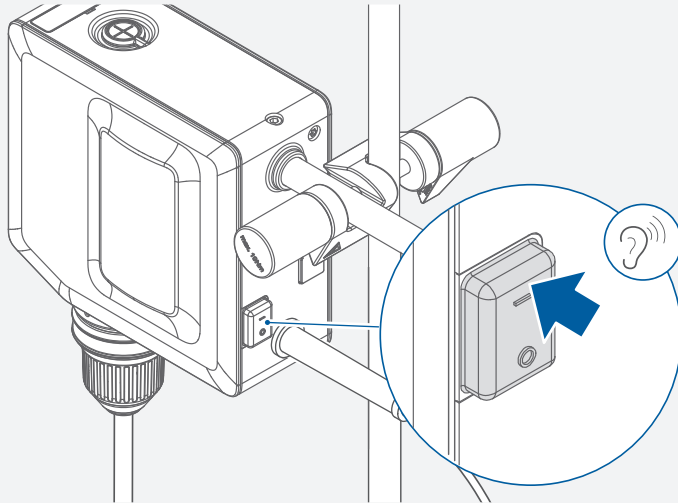

2.1

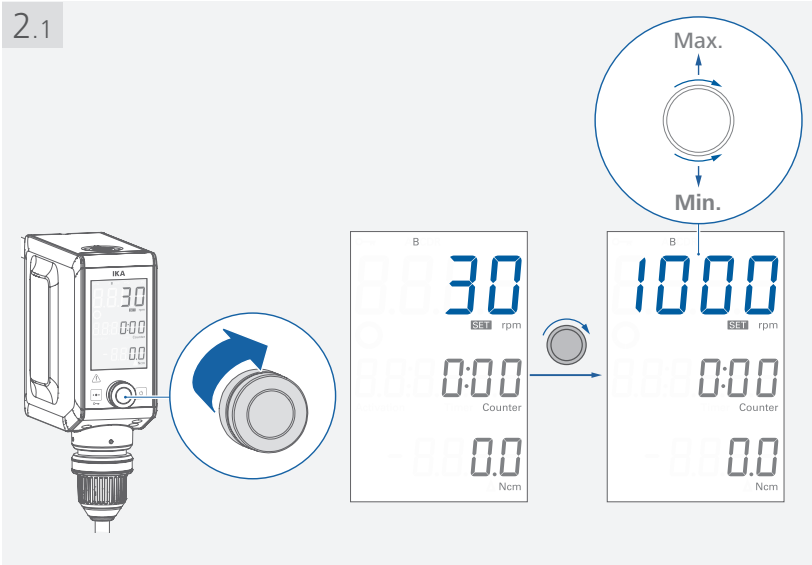

2.2

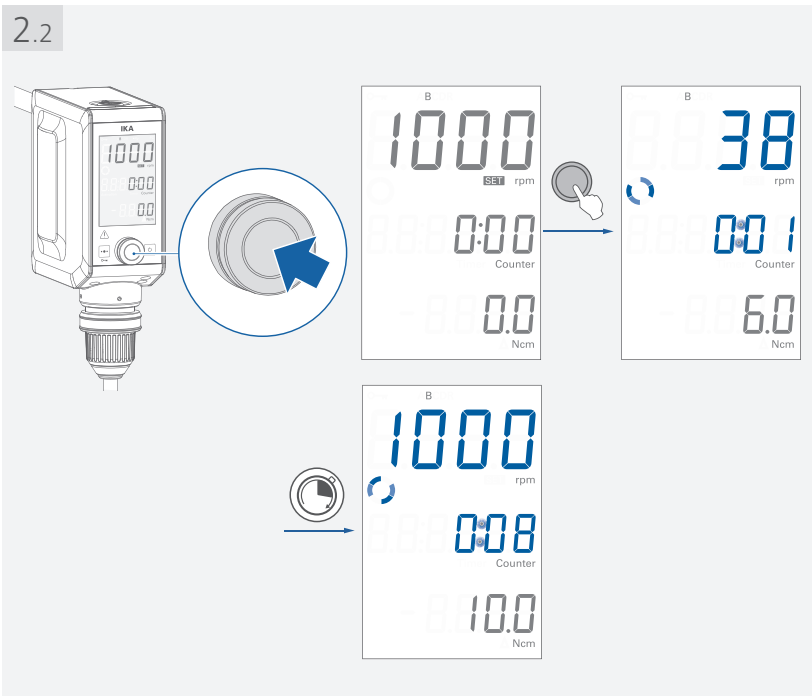

### 3.1

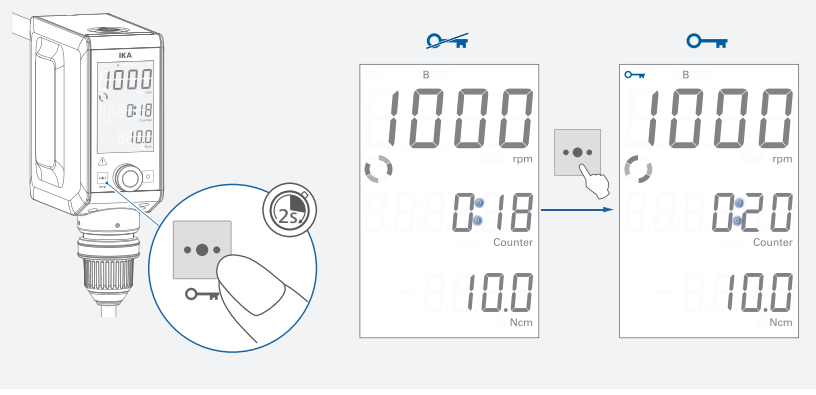

### 3.2

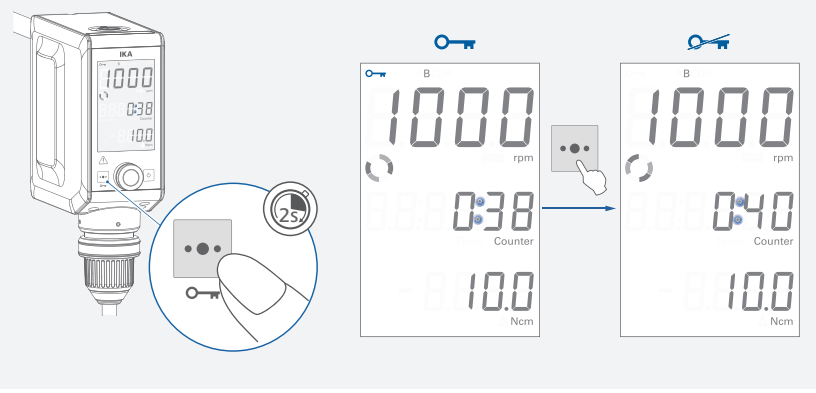

4

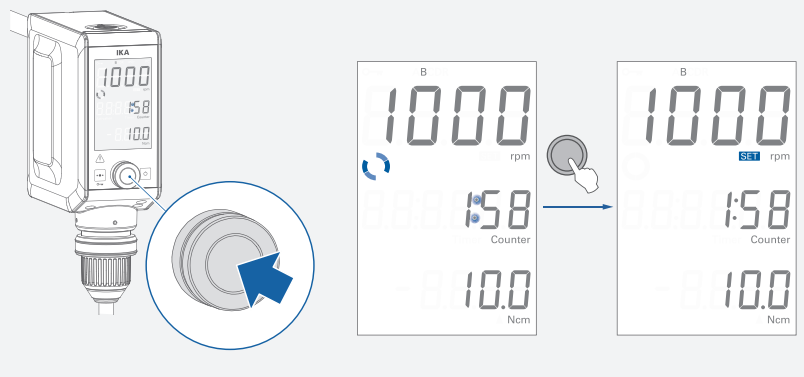

5

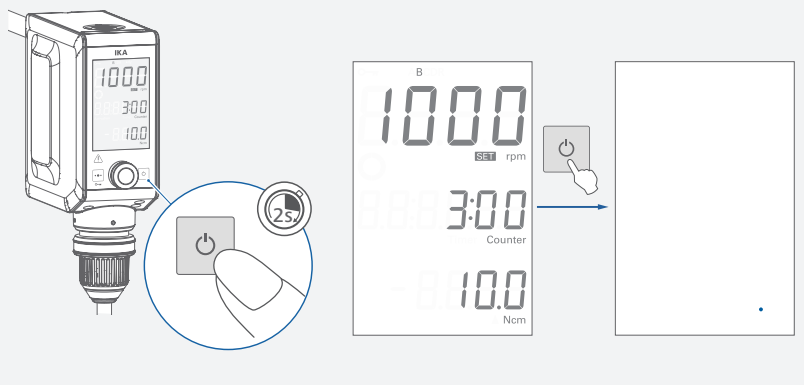



## Menu navigation and structure

### /// Menu navigation

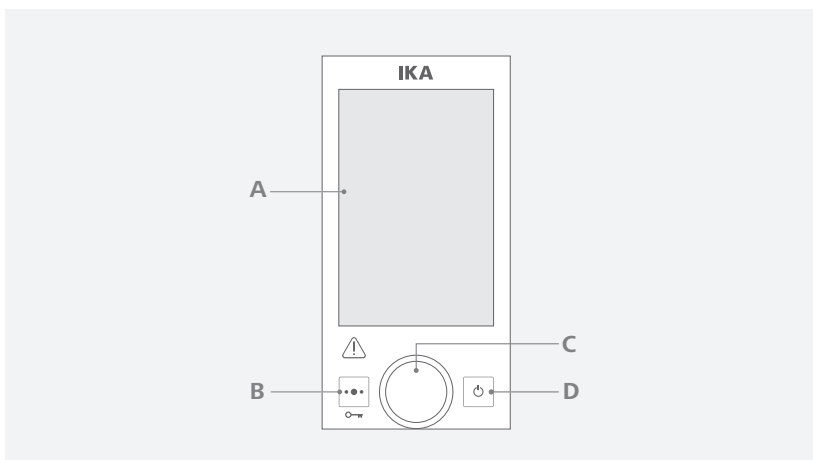

- › Activate the editing of menu option by touching multifunction button (B) shortly.
- › Activate the editing of next menu option by touching multifunction button (B) shortly again.
- › Current selected menu option blinks.
- › Edit the desired menu option by turning and pressing the control knob (C).

### /// Menu structure

		Default settings
Menu	Counter .....	Activated
	Timer .....	-
	Torque reset .....	-
	Operating mode	
	A .....	-
	B .....	Activated
	C .....	-
	Torque (Ncm) range .....	20 Ncm [EUROSTAR 20 digital] 40 Ncm [EUROSTAR 40 digital] 60 Ncm [EUROSTAR 60 digital] 60 Ncm [EUROSTAR 100 digital] 20 Ncm [EUROSTAR 20 high speed digital] 350 Ncm [EUROSTAR 400 high torque digital]
	Speed (rpm) range .....	2000 rpm [EUROSTAR 20 digital] 2000 rpm [EUROSTAR 40 digital] 2000 rpm [EUROSTAR 60 digital] 2000 rpm [EUROSTAR 100 digital] 6000 rpm [EUROSTAR 20 high speed digital] 300 rpm [EUROSTAR 400 high torque digital]
	Torque calibration .....	-
	Factory reset .....	-



## Technical data

		EUROSTAR 20 digital	EUROSTAR 40 digital	EUROSTAR 60 digital
Speed range under nominal load	rpm	0/30 ... 2000		
Speed adjustment		Stepless		
Speed display		LCD		
Speed setting accuracy	rpm	± 1		
Speed measurement deviation		Speed < 300 rpm: ± 3 rpm / Speed > 300 rpm: ± 1 %		
Max. torque at stirrer shaft (see section "Torque graph")	Ncm	40 (at 30 ... 600 rpm)	60 (at 30 ... 200 rpm)	100 (at 30 ... 400 rpm)
		40 ... 20 (at 600 ... 2000 rpm)	60 ... 40 (at 200 ... 2000 rpm)	100 ... 60 (at 400 ... 2000 rpm)
Torque trend measurement		Yes		
Torque trend display		Yes		
Torque measurement deviation	Ncm	± 6		
Max. stirring quantity (water)	l	25	40	60
Max. viscosity	mPa·s	10000	30000	50000
Timer/Counter function		Yes		
Timer/Counter display		LCD		
Max. Timer/Counter		100 hours (99:59:59 [hour:minute:second])		
Permitted on time	%	100		
Nominal voltage	VAC	100 ... 230		
Frequency	Hz	50/60		
Max. input power	W	70	118	168
Max. output power at stirring shaft	W	42	84	131
Noise level without stirring tool	dB (A)	52		
Interface		USB, RS 232		
IP code according to EN 60529		IP 54		
Protection class		I		
Oversvoltage category		II		
Contamination level		2		
Protection at overload		Yes / motor current limitation		
Permissible ambient temperature	°C	5 ... 40		
Permissible relative humidity	%	80		
Drive		Brushless motor		
Clamping chuck-clamping range	mm	0.5 ... 10		
Hollow shaft internal diameter	mm	11		
Extension arm (Ø x L)	mm	16 x 220		
Dimensions (W x D x H) (without extension arm)	mm	89 x 191 x 237		
Weight (with extension arm and clamping chuck)	kg	3.8		
Operation at a terrestrial altitude	m	max. 2000		

		EUROSTAR 100 digital	EUROSTAR 20 high speed digital	EUROSTAR 400 high torque digital
Speed range under nominal load	rpm	0/30 ... 2000	0/150 ... 6000	0/10 ... 300
Speed adjustment		Stepless		
Speed display		LCD		
Speed setting accuracy	rpm	± 1		
Speed measurement deviation		Speed < 300 rpm: ± 3 rpm / Speed > 300 rpm: ± 1 %		
Max. torque at stirrer shaft (see section "Torque graph")	Ncm	200 (up to 20 minutes <sup>❶</sup> ) (at 30 ... 600 rpm)	40 (at 150 ... 600 rpm)	400 (at 10 ... 260 rpm)
		120 (at 30 ... 600 rpm)		
		120 ... 100 (at 600 ... 1300 rpm)	40 ... 20 (at 600 ... 6000 rpm)	400 ... 350 (at 260 ... 300 rpm)
		100 ... 60 (at 1300 ... 2000 rpm)		
Torque trend measurement		Yes		
Torque trend display		Yes		
Torque measurement deviation	Ncm	± 6	± 6	± 30
Max. stirring quantity (water)	l	100	20	150
Max. viscosity	mPa·s	70000	10000	100000
Timer/Counter function		Yes		
Timer/Counter display		LCD		
Max. Timer/Counter		100 hours (99:59:59 [hour:minute:second])		
Permitted on time	%	100		
Nominal voltage	VAC	100 ... 230		
Frequency	Hz	50/60		
Max. input power	W	186	176	174
Max. output power at stirring shaft	W	136	125	142
Noise level without stirring tool	dB (A)	52		
Interface		USB, RS 232		
IP code according to EN 60529		IP 54		
Protection class		I		
Overvoltage category		II		
Contamination level		2		
Protection at overload		Yes / motor current limitation		
Permissible ambient temperature	°C	5 ... 40		
Permissible relative humidity	%	80		
Drive		Brushless motor		
Clamping chuck-clamping range	mm	0.5 ... 10	❷	0.5 ... 10
Hollow shaft internal diameter	mm	11	-	11
Extension arm (∅ × L)	mm	16 × 220		
Dimensions (W × D × H) (without extension arm)	mm	89 x 191 x 237	89 x 191 x 306	89 x 191 x 240
Weight (with extension arm and clamping chuck)	kg	3.8	5.2	3.8
Operation at a terrestrial altitude	m	max. 2000		

Subject to technical changes!



- ❶ Up to 20 minutes, depending on room temperature and voltage etc..
- ❷ Conical attachment for precision shaft **R 6000**, screw on stirring tool (e.g. **R 1401**).