

IKA

designed for scientists

HRC 2 lite

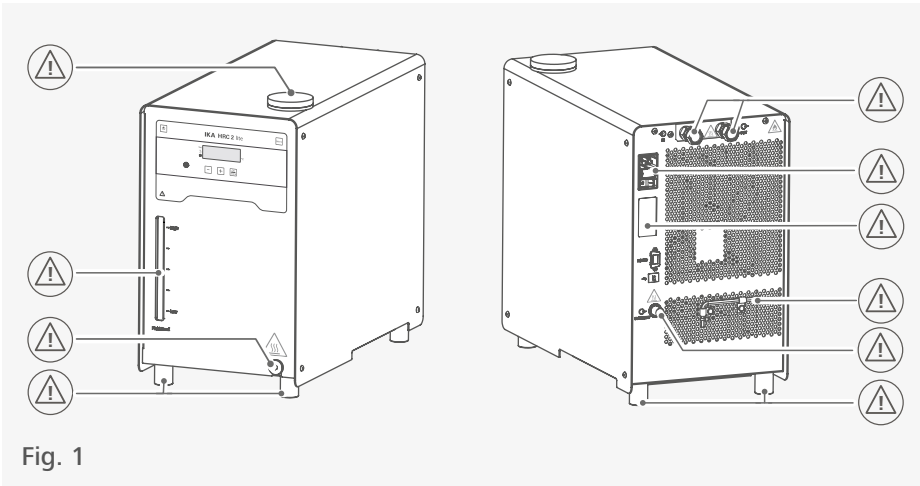











Fig. 1

	EU Declaration of conformity	6
	Explication of warning symbols	6
	Safety instructions.....	7
	Intended use.....	11
	Unpacking	11
	Operator panel and display	12
	Installation.....	13
	Operation	16
	Menu navigation and structure	20
	Transportation and storage	25
	Fluids (Standard information for IKA fluid).....	26
	Interfaces and outputs.....	27
	Maintenance and cleaning.....	30
	Error codes	31
	Accessories	33
	Technical Data	34
	Warranty	35
	Pump performance curve.....	35



EU Declaration of conformity







We declare under our sole responsibility that this product corresponds to the regulations 2014/35/EU, 2006/42/EC, 2014/30/EU and 2011/65/EU and conforms with the standards or other normative documents: EN 61010-1, EN 61010-2-010, EN 61010-2-011, EN 61326-1, EN 60529, EN ISO 12100 and DIN 12876-1, -2, -3.

A copy of the complete EU Declaration of Conformity or further declarations of conformity can be requested.





Explication of warning symbols

/// Warning symbols

-  **Danger!** Indicates an (extremely) hazardous situation, which, if not avoided, will result in death, serious injury.
-  **Warning!** Indicates a hazardous situation, which, if not avoided, can result in death, serious injury.
-  **Caution!** Indicates a potentially hazardous situation, which, if not avoided, can result in injury.
-  **Notice!** Indicates practices which, if not avoided, can result in equipment damage.
-  **Warning!** Indicates the risk of fire or explosion!
-  **Caution!** Indicates a hazardous situation that can cause from a hot surface!

/// General Symbols

- A** — Position number
-  Correct / Result
Shows the correct execution or the result of an action step.
-  Wrong
Shows the incorrect execution of an action step.
-  Note
Displays action steps that require particular attention to detail.

Safety instructions



/// General information

- › **Read the operating instructions completely before starting up and follow the safety instructions.**
- › Keep the operating instructions in a place where it can be accessed by everyone.
- › Ensure that only trained staff work with the device.
- › Follow the safety instructions, guidelines, occupational health and safety and accident prevention regulations.
- › The device must only be used in a technically perfect condition.

Notice!

- › Pay attention to the marked sites in Fig. 1.

/// Device setup

Caution!

- › The power switch of the device must be accessed immediately, directly and without risk at any time. If access to the power switch cannot be ensured, an additional emergency stop switch that can be easily accessed must be installed in the work area.

Notice!

- › Set up the device in a spacious area on an even, stable, clean, non-slip, dry and fireproof surface.
- › Insufficient ventilation may result in the formation of explosive mixtures. Only use the device in well ventilated areas.

/// Working with the device

Danger!

- › Do not use the device in explosive atmospheres, it is not EX-protected.
- › With substances capable of forming an explosive mixture, appropriate safety measures must be applied, e.g. working under a fume hood.
- › To avoid body injury and property damage, observe the relevant safety and accident prevention measures when processing hazardous materials.

Warning!

- › Process pathogenic material only in closed vessels under a suitable fume hood. Please contact IKA application support if you have any question.
- › When using critical or hazardous materials in your processes, IKA recommends to use additional appropriate measures to ensure safety in the experiment. For example, users can implement comprehensive monitoring equipment.
- › The safety circuit (safe temperature) must be adjusted so that the maximum permissible temperature cannot be exceeded even in the event of a fault. Check the safe temperature circuit on a regular basis (see section "Setting the safety temperature").

Caution!

- › Do not start up the device if:
 - It is damaged or leaking
 - Cable (not only the power cable) is damaged.
- › Power cable should not get in contact with hot parts and fluids.
- › Be careful when filling a hot bath.

Caution!

- › At high operating temperature, the temperature of housing parts, surfaces and tubes can exceed 70 ° C.

Notice!

- › Covers or parts that can be removed from the device without tools must later be refitted to ensure safe operation. This will prevent the infiltration of foreign objects, liquids and other contaminants.
- › The feet of the device must be clean and undamaged.
- › Always empty the bath if the unit is unused for long time.

- › A laboratory circulator heats / refrigerates and circulates fluid according to specified parameters. This involves hazards due to high and low temperatures and general hazards due to the device of electrical energy. The user safety can not be ensured simply with design requirements on the part of the device. Further hazard sources may arise due to the type of tempering fluid, e.g. by exceeding or undercutting certain temperature thresholds or by the breakage of the container and reaction with the carrier fluid. It is not possible to consider all eventualities. They remain largely subject to the judgment and responsibility of the operator. For this reason, it become necessary for user to take other precautionary safety measures.
- › The device may only be used as prescribed and as described in these operating instructions. This includes operation by instructed specialist personnel.
- › When device is used for external circulation, extra precaution must be taken for hot / cold fluid leakage due to damaged hose.
 - Use suitable hoses for connection.
 - Secure hoses and tubes against slippage and avoid kinks.
 - Check hoses, tubes and bath at regular intervals for possible material fatigue (cracks/leaks).
- › Do not transport or empty the bath while it is still hot / cold. This may result in accidents, especially scalding injuries.
- › Always empty the bath before moving the unit.

/// Accessories

- › Protect the device and accessories from bumping and impacting.
- › Check the device and accessories beforehand for damage each time when you use them. Do not use damaged components.
- › Safe operation is only guaranteed with the accessories described in the "Accessories" section.

/// Power supply / switching off the device

- › The voltage stated on the type plate must correspond to the power voltage.
- › The device can only be disconnected from the power supply by pulling out the power plug or the connector plug.
- › The device must only be operated with the original power cord set.
- › The socket for the power cord must be easily accessible.
- › Socket must be earthed (protective ground contact).
- › After a power failure during operation, the device may start automatically (depending on operating mode).
- › Disconnect the power plug before attaching or changing any accessories.
- › Disconnect the power plug before cleaning, maintenance and transportation of the unit.

/// Maintenance

- › The device must only be opened by trained specialists, even during repair. The device must be unplugged from the power supply before opening. Live parts inside the device may still be live for some time after unplugging from the power supply.

/// Disposal instructions

- › The device, accessories and packaging must be disposed of in accordance with local and national regulations.

/// Fluid

Warning!

- › Only use the fluids, which fulfill the requirements for safety, health and device compatibility. Be aware of the chemical hazards that may be associated with the bath fluid used. Observe all safety warning for the fluids.
- › Depending on the bath fluid used and the type of operation, toxic can arise. Ensure suitable extraction.
- › Do not use any fluid which may cause dangerous reactions during processing.
- › The safety temperature must be set in accordance with EN 61010-2-010 chapter "Requirements for equipment containing or using flammable liquids".
 - The surface temperature of the flammable medium that is exposed to air should not exceed its flash point.
A danger usually arises if a medium is heated in open vessels.
 - The surface temperature of the heating element (e.g. the heating plate of a magnetic stirrer and/or the heater of a thermostat) at the surface of the flammable medium and in contact with air should not exceed the value of $(t - 25) \text{ °C}$ (= set value of the safety circuit), whereby t is the fire point of the medium. In case of uncertainties regarding the fire point, we recommend using the lower flash point as t .
A danger usually arises if a medium is heated in glass vessels (glass breakage).
- › If a setting made by the user (medium temperature or safety temperature) could bring a flammable medium into a state in which the conditions mentioned above could be exceeded, additional measures must be introduced that will protect the user from this danger.
- › Examine regularly the function of the safety temperature limiter.

⚠ Caution!

- › Beware of the risk of burning due to delay in boiling!

⚠ Notice!

- › Only use recommended bath fluid. Only use non-acid and non corroding fluid.
- › Never operate the device without sufficient fluid! Check the fluid level detection at a regular basis.
- › If water is used at higher temperature, there is heavy loss of fluid due to the evaporation of the steam.
When changing the bath fluid type, must remove the remaining water from the complete system (including hoses and external devices). When doing this, also open the stopper and union nuts caps of the pump outputs and inputs and blow compressed air through all the pump outputs and inputs!
- › Continuous monitoring of the filling level of the bath fluid is required, especially at high temperatures.
- › To ensure a sufficient fluid circulation, the viscosity of the bath fluid must not exceed of 50 mm²/s at the lowest operating temperature.
- › Untreated tap water is not recommended. It is recommended to use distilled water or high purity water (ion exchangers) and add 0.1 g soda (sodium carbonate Na₂CO₃) /liter, to reduce corrosive properties.
- › Don't use following fluids:
 - Untreated tap water
 - Acids or bases
 - Solutions with halides: chlorides, fluorides, bromides, iodides or sulfur
 - Bleach (Sodium Hypochlorite)
 - Solution with chromates or chromium salts
 - Glycerine
 - Ferrous water.

/// Refrigerant

⚠ Warning!

- › The device is not allowed to be used in an ATEX (Atmosphere Explosible) zone.
- › Flammable refrigerant used. Do not use mechanical devices or other means to accelerate the defrosting process, other than those recommended by the manufacturer.
- › Do not damage the refrigerant circuit.
- › Insufficient ventilation may result in the formation of explosive mixtures. Only use the device in well ventilated areas and keep all air vents open.
- › Flammable refrigerant used. Only the manufacturer may open and repair the closed refrigeration system.
- › The minimum room size is 10 m³, so that in the event of an error (exit of the complete refrigerant filling quantity) no flammable refrigerant-air mixture can arise (R 290 max. 8 g/m³ ambient air).
- › The device has been constructed to the requirements of EU (European Union) and EFTA (European Free Trade Association) countries.

Intended use

/// Use

Use **HRC 2 lite** for tempering (heating / cooling) and circulating fluids.

Intended use: Tabletop device

/// Range of use

Indoor environments similar to that a laboratory of research, teaching, trade or industry.

The safety of the user cannot be guaranteed:

- › if the device is operated with accessories that are not supplied or recommended by the manufacturer.
- › if the device is operated improperly or contrary to the manufacture's specifications.
- › if the device or the printed circuit board are modified by third parties.

Unpacking

- › Please unpack the device carefully.
- › Any damage should be notified immediately to the shipping agent (post office, railway network or logistics company).

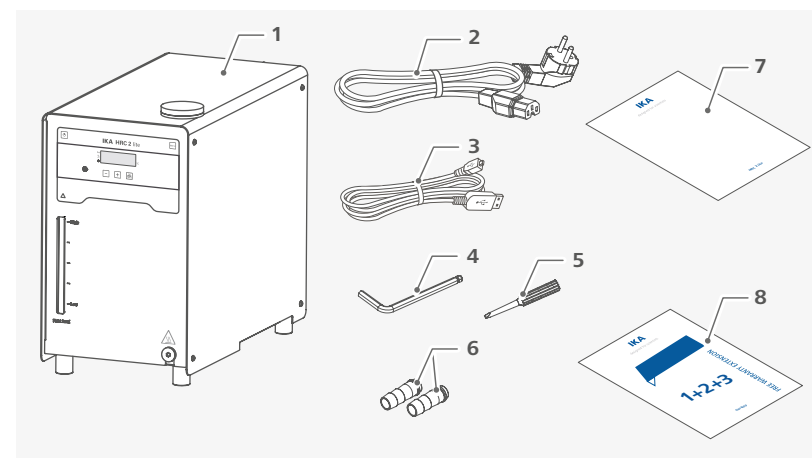

1	HRC 2 lite	5	Screwdriver (use for safety circuit)
2	Power cable	6	Hose olives DN 8 (2 x)
3	USB cable	7	User guide
4	Hexagon socket offset screw key	8	Warranty card



Operator panel and display

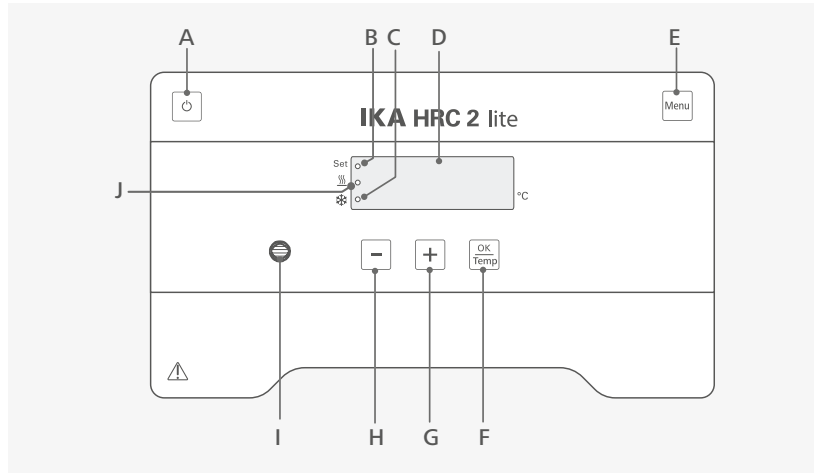

A	On / Off button	Switch on / off the device.
B	LED, "Set"	The LED lights up at the same time as the set value is displayed.
C	LED, cooling	The lighted LED indicates the cooling function is activated.
D	LED display	Display the settings and actual temperature values.
E	"Menu" button	Press it once: menu option is display. Press it once again: back to working screen.
F	"OK / Temp" button	Start / Stop the tempering (heating / cooling) function. Confirm the menu options.
G	Plus (+) button	Increase the temperature setting. Navigation, selecting the settings in the menu. Change the menu value setting.
H	Minus (-) button	Decrease the temperature setting. Navigation, selecting the settings in the menu. Change the menu value setting.
I	Adjustable safety circuit	Adjust the safety temperature limit.
J	LED, heating	The lighted LED indicates the heating function is activated.

Installation

- › Place the unit on an even, stable, clean, non-slip, dry and fireproof surface.
- › Keep at least 20 cm of open space on the front and rear side.
- › The place for installation should be large enough and provide sufficient air ventilation to ensure the room does not warm up excessively because of the heat from device radiates to the environment.
- › Do not set up the device in the immediate vicinity of heat sources and do not expose to sun light.
- › Cooling machine, pump motor and electronics produce intrinsic heat that is dissipated via the venting grids! Never cover these venting grids!



/// Connecting the tubings and external device

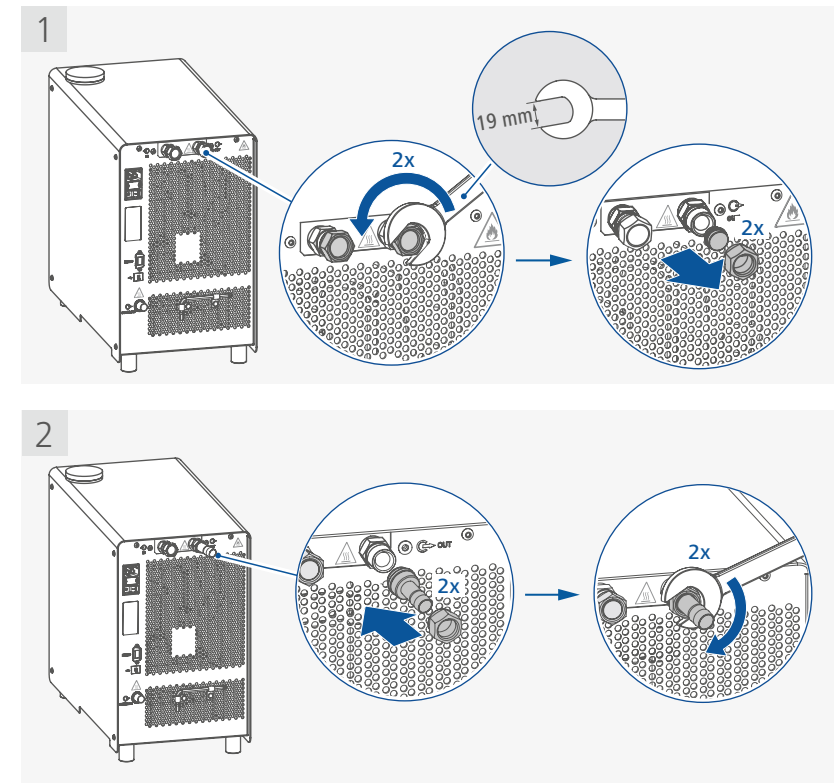

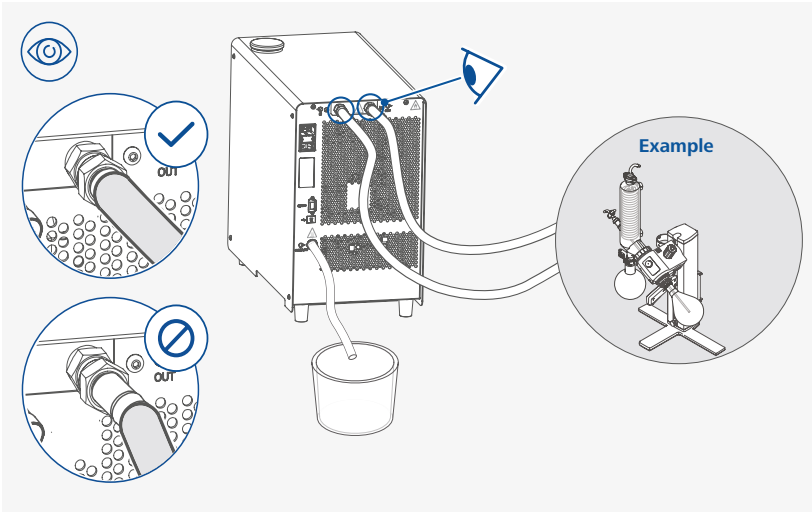
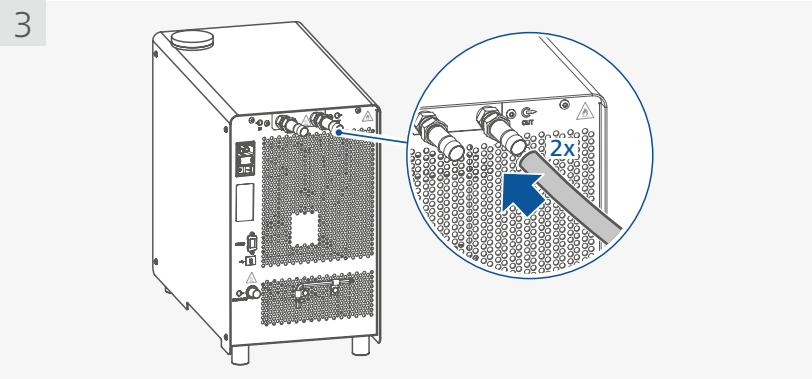

/// Filling the device

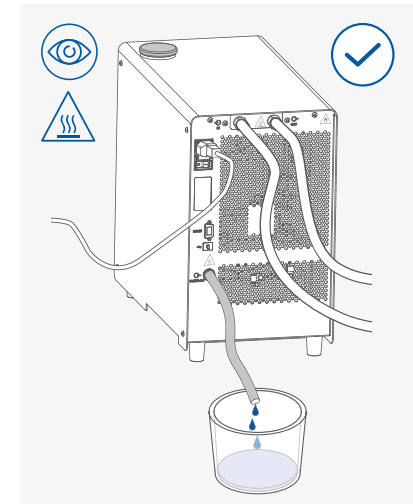
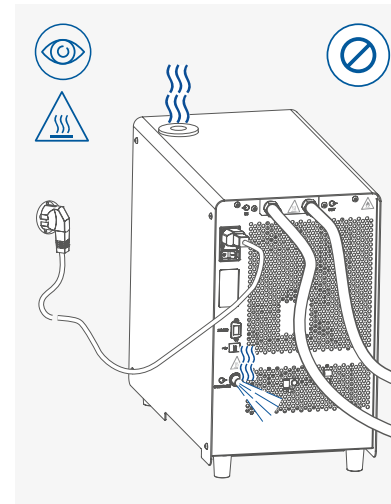
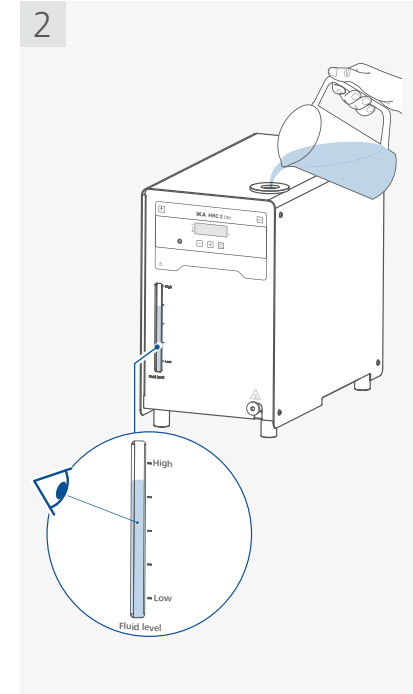
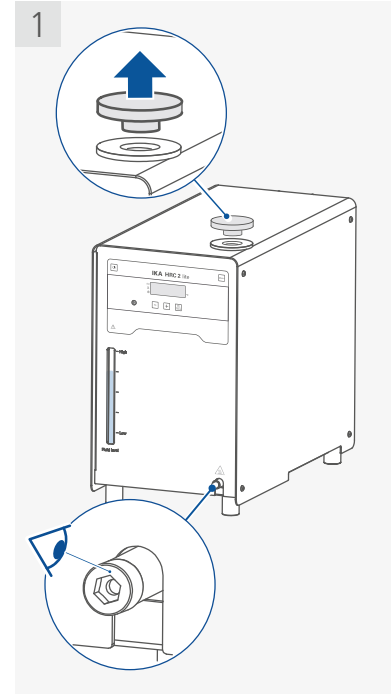

- Caution!**
- › Put the filling opening lid back and meanwhile connect a suitable hose to the "Overflow" connector prior to operating the device, especially when using the device for heating water. Or else, the hot steam may spray out!

/// Connecting to power

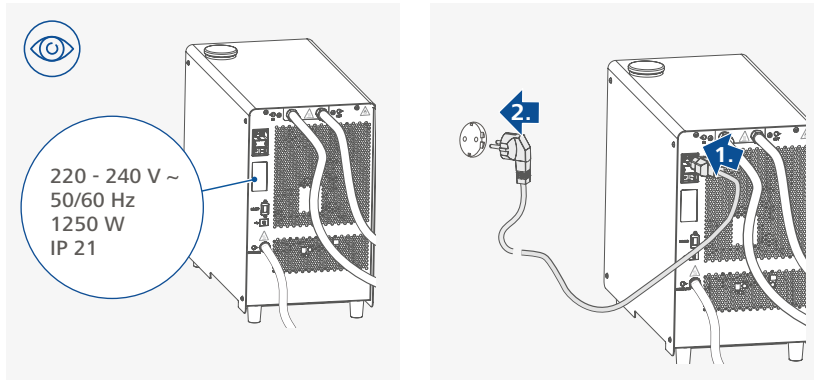

⚠ Notice!

Check whether the voltage specified on the type plate matches the power voltage available.



Operation

⚠ Notice!

Before commissioning, make sure that the device has not been moved in one hour.
The socket used must be earthed (fitted with earth contact).
Observe the ambient conditions (temperature, humidity etc.) listed under "Technical Data".

/// Switching on

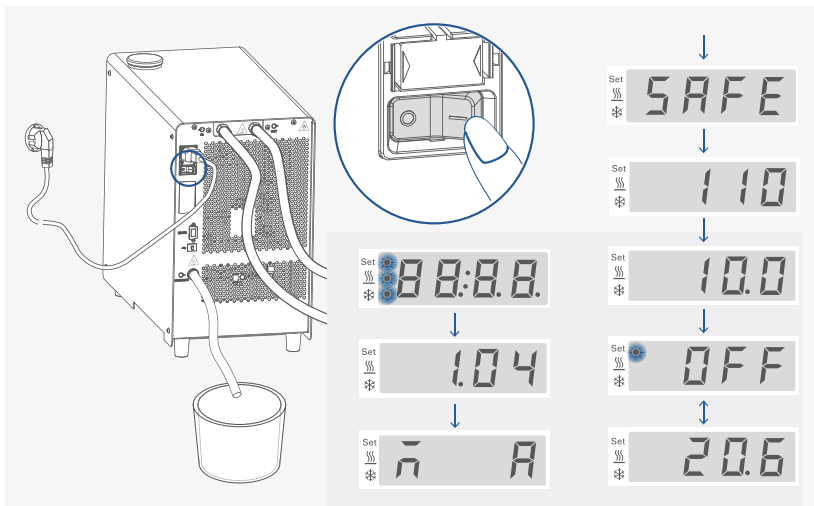

/// Setting the safety temperature

Setting the safety temperature with screwdriver delivered with the device.

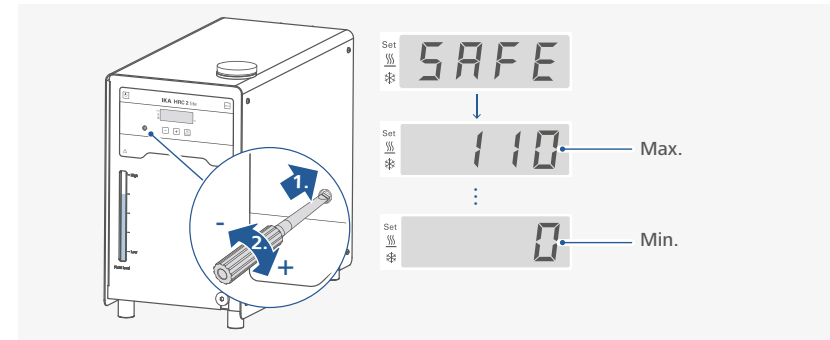

Factory setting: approximate max. value.
Adjust range: 0 ... 110 °C.

⚠ Caution!

The safety temperature must always be set to at least 25 °C lower than the fire point of the fluid used. In case of uncertainties regarding the fire point, we recommend setting the safety temperature to a least 25 °C lower than the flash point of the fluid used.

/// Setting temperature

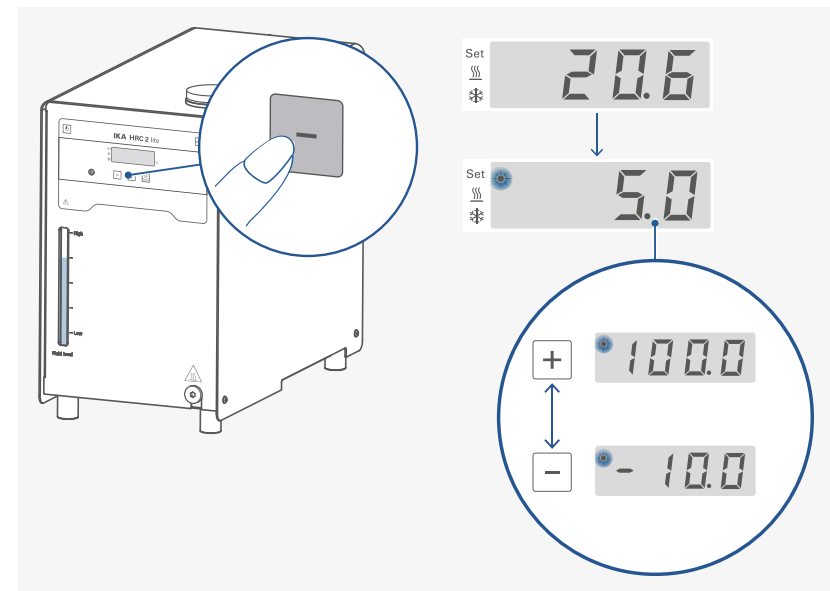

/// Starting tempering (heating / cooling) function

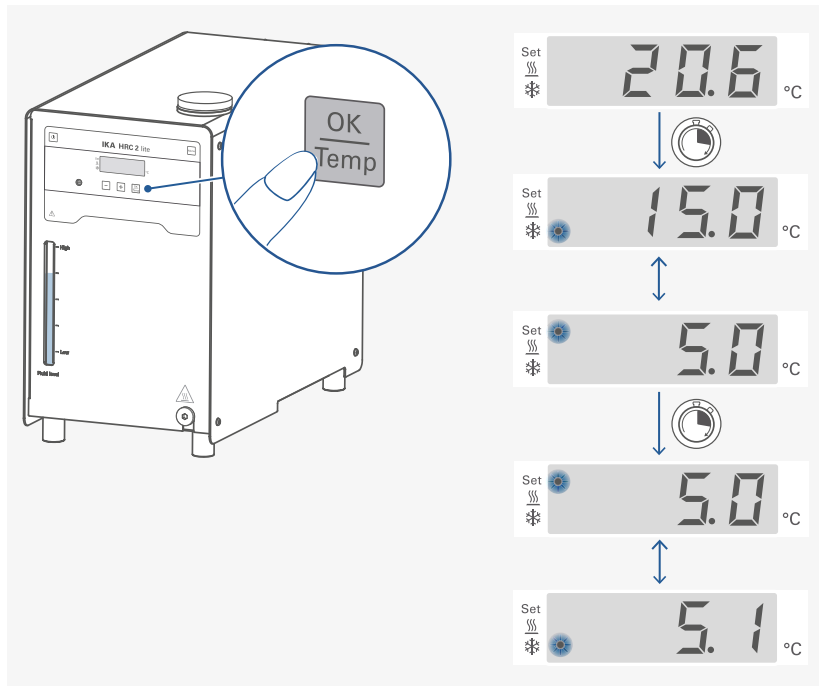

/// Switching off

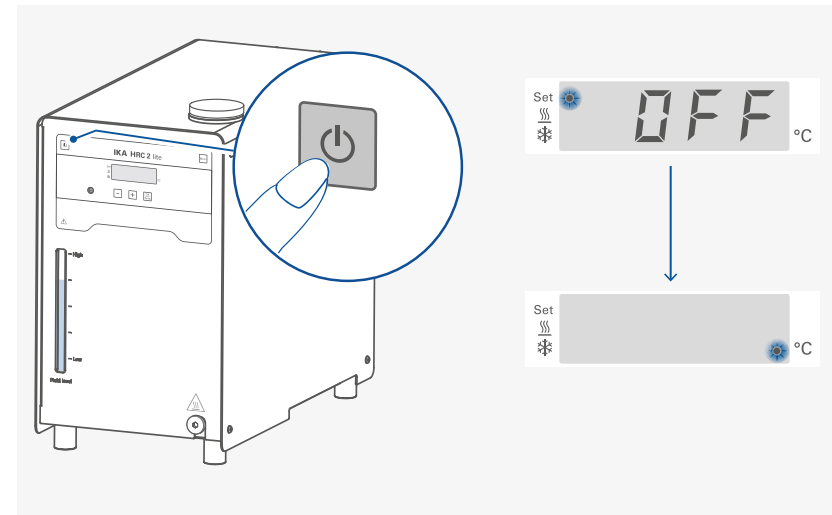

/// Stopping tempering (heating / cooling) function

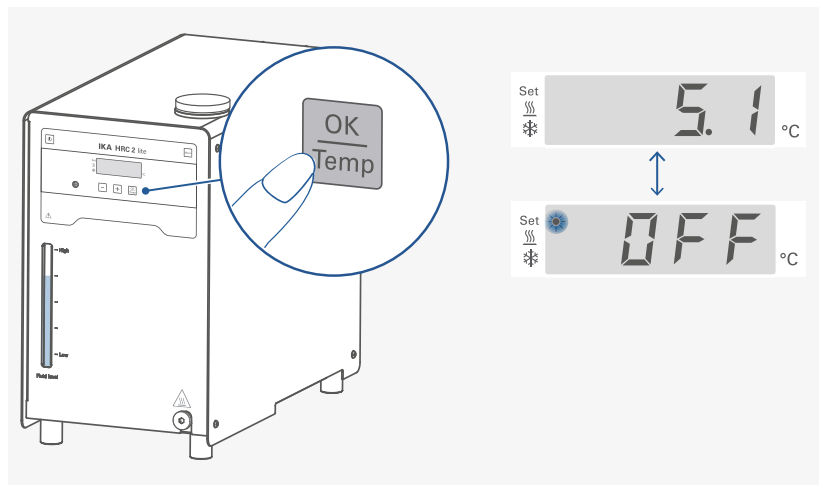



Menu navigation and structure

/// Menu navigation

- › Enter the menu by pressing “Menu” button (E).
- › Press the plus (+) button (G) or minus (-) button (H) to change the menu options.
- › Press “OK / Temp” button (F) to enter the select menu option.
- › Press the plus (+) button (G) or minus (-) button (H) to change the menu value settings.
- › Confirm the menu settings by pressing the “OK / Temp” button (F).

/// Menu structure

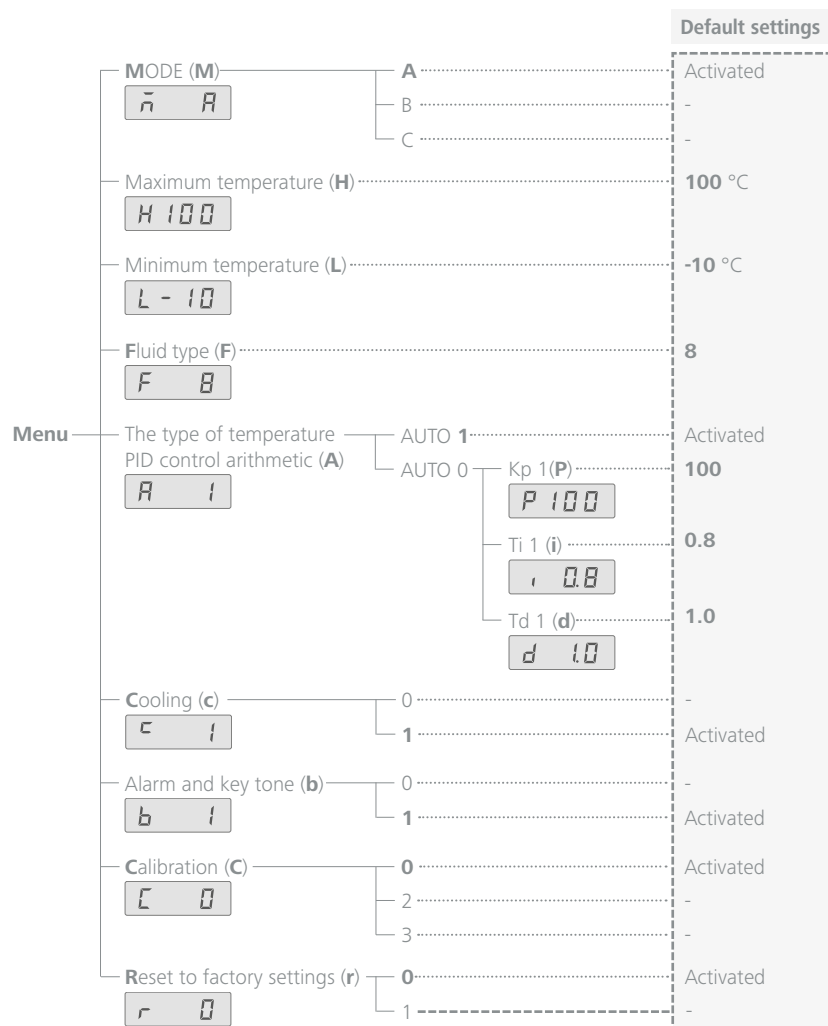

/// Menu details

Operating mode (M):



Mode A: After power on/power failure no automatic restart of functions.

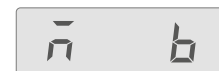

Mode B: After power on/power failure automatic restart of functions, depending on previous settings.

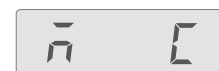

Mode C: Set values (set in mode A or B) cannot be changed. After power on/power failure automatic restart of functions, depending on previous settings.

Maximum temperature (H):



The maximum adjustable value: 100 °C.

Minimum temperature (L):



The minimum adjustable value: -10 °C.

Fluid type (F):

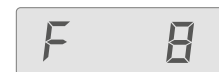

The chosen fluid (No.) limits the maximum and minimum temperature. Customized fluid (No.: 8) enables the whole working temperature range. See Section “Fluids (Standard information for IKA fluid)”.

Temperature control type (A 1):

A 1

AUTO 1: AUTO 1 is the default setting. The default PID settings are used automatically.

Heating up curve in AUTO 1 control (AUTO 1):

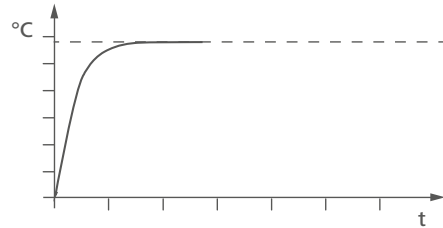

AUTO 0: For special requirements, AUTO 0 can be used with manual adjustment of the control parameters.

If the PID control (AUTO 0) option is selected, the following items including **Kp 1**, **Ti 1** and **Td 1** could be set. Otherwise they are not displayed in the menu list.

Note: Inappropriate settings may produce the following heating up curves:

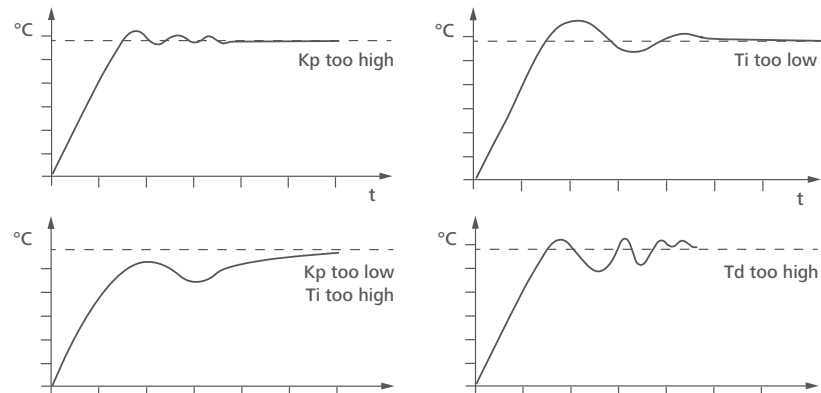

Proportional coefficient of PID (Kp 1)

P 100

The proportional coefficient **Kp** is the controller amplification and determines how strongly the control deviation (the difference between the target temperature and actual temperature) directly affects the control variable (cooling down time). **Kp** values that are too large can lead to the controller overshooting.

Integral time of PID (Ti 1)

, 0.8

The integral time **Ti (s)** is the correction time and determines how strongly the duration of the control deviation affects the control variable. **Ti** compensates an existing control deviation. A high **Ti** means a smaller and slower effect on the control variable. **Ti** values that are too small can lead to instability of the controller.

Differential time of PID (Td 1)

d 1.0

The differential time **Td (s)** is the derivative time and determines how strongly the rate of change of the control deviation affects the control variable. **Td** compensates for rapid control deviations. A high **Td** means a smaller and slower effect on the control variable. **Td** values that are too large can lead to instability of the controller.

Cooling (c):

c 1

c 0: Cooling function is deactivated.

c 1: Cooling function is activated.

Alarm and button tone (b):

b 1

b 0: no alarm and button tone

b 1: alarm and button tone is activated

Calibration and adjustment (C):

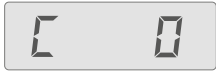

- C 0: Reset calibration
- C 2: 2-point calibration
- C 3: 3-point calibration.

Example: 2-point calibration:

Dip the temperature sensor of the reference measuring instrument into the bath fluid. Select 2-point calibration with plus (+) button / minus (-) button and "OK / Temp" button in the menu.



Press the "OK / Temp" button to start the 2-point calibration. The last calibration temperature value flashes.



Set the first point temperature (step 1, e.g. 10 °C) with plus (+) button / minus (-) button.



Confirm the setting by pressing "OK / Temp" button. The unit now starts and controls to the set value.

When the temperature has reached the set value and has become constant, the value in the screen changes from the set temperature value to "0.0" and flashes.



Input the calibration value from the reference measuring instrument (e.g. 10.3 °C) with plus (+) button / minus (-) button.

Note: the difference between the input calibration value from reference measuring instrument and set value is limited to less than +/-3 K.

Confirm the value by pressing the "OK / Temp" button. The first point calibration is finished now. The screen displays the set value for the first point calibration and flashes.



Calibration of the other points is performed in the same way.

Reset to factory settings (r):



- r 0: Without resetting to factory settings.
- r 1: Resetting to factory settings.

Transportation and storage

- › Remove the power cord before transporting the device.
- › The device must be protected against mechanical impact, vibrations, dust deposits and corrosive ambient air during transportation and storage. In addition, take care to ensure that the relative humidity does not exceed 80 %.
- › The device must be completely emptied before transportation and storage.

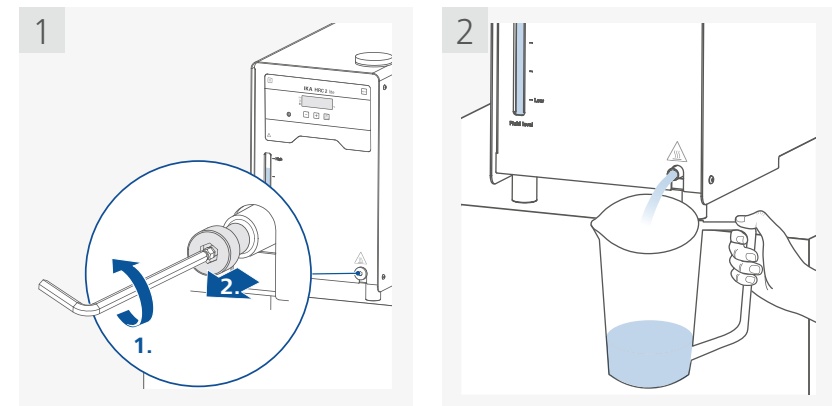

- › Beware of the high dead weight of the device when transporting.
- › Ensure that your fingers do not get crushed when setting down the device.
- › The device can be transported:
 - by hand / unaided (2 to 4 persons).
 - with a pallet truck.

Caution!

Beware of tipping over because of the high center of gravity when lift and move the device!



Fluids (Standard information for IKA fluid)

No.	IKA Designation	Operating temperature range for open bath application (°C)	Operating temperature range for closed bath applications (°C)	Safety temperature (°C)	Flash point (°C)
0	CF.EG28.N10.80.8	-10 ... 80	-10 ... 80	90	115
1	CF.EG39.N20.80.16	-20 ... 80	-20 ... 80	90	115
2	CF.EG44.N25.80.19	-25 ... 80	-25 ... 80	90	115
3	CF.EG48.N30.80.22	-30 ... 80	-30 ... 80	90	115
4	UF.Si.N30.150.10LV	-30 ... 130	-30 ... 150	145 ①	>170
5	HF.Si.20.200.50	20 ... 200	20 ... 200	255	>280
6	HF.Si.20.250.50A	20 ... 200	20 ... 250	255	>280
7	Water ②	5 ... 95	5 ... 95	-	-
8	Customized ③				

Check the suitability of the liquid according to your application.

Nomenclature for IKA fluids:

CF.EG28.N10.80.8 --

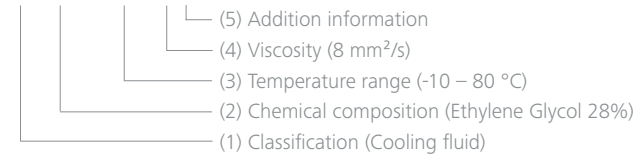

- (1) Classification:
HF: Heating Fluid
CF: Cooling Fluid
UF: Universal Fluid
 - (2) Chemical composition:
Si: Silicone oil
EG: Ethylene Glycol
 - (3) Temperature range: (Minimum temperature. Maximum temperature)
N: Negative Temperature
 - (4) Viscosity:
Viscosity at 25 °C for Heating Fluid (HF)
Viscosity at -20 °C for Cooling Fluid (CF)
Viscosity at 25 °C for Universal Fluid (UF)
Dynamic viscosity [mPa•s] is a product of kinematic viscosity [mm²/s] and density [kg/m³] of the fluid divided by 1000.
 - (5) Additional information:
A: Oil Additives
LV: Low Viscosity
- ① **Note:** for open bath application!
- ② **Note:** Tap water may be unsuitable for operation because the calcium carbonate content may cause calcification.
High purity water (from ion exchangers) and distilled or bi-distilled water are unsuitable for operation due to corrosive properties of these media. High purity water and distillates are suitable as a medium after adding 0.1 g soda (Na₂CO₃, sodium carbonate) per liter of water.
- ③ **Note:** The temperature limit values are adjustable in accordance with the fluid used.

Interfaces and outputs

The device can be operated in "Remote" mode via the RS 232 port or the USB port connected to a PC and with the laboratory software Labworldsoft®.
The device software can also be updated with a PC via the RS 232 or USB port.

Note: Please comply with the system requirements together with the operating instructions and help section included with the software.

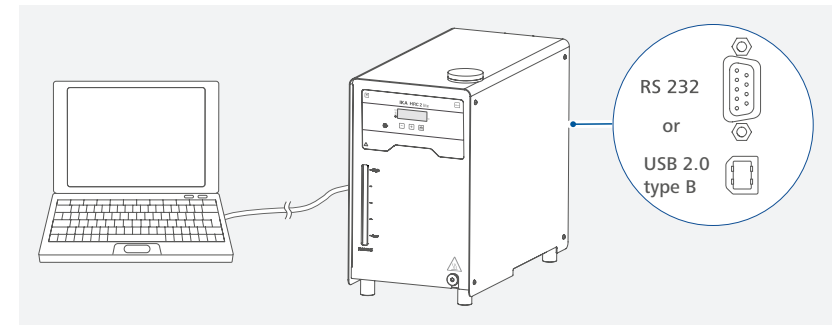

/// USB interface

The Universal Serial Bus (USB) is a serial bus for connecting the device to the PC. Equipped with USB devices can be connected to a PC during operation (hot plugging).
Connected devices and their properties are automatically recognized.

/// USB device drivers

First, download the latest driver for IKA devices with USB interface.
Install the driver by running the setup file. Connect the IKA device through the USB data cable to the PC. The data communication is via a virtual COM port. Configuration, command syntax and commands of the virtual COM ports are as described in RS 232 interface.

Note: the USB driver is necessary for Windows 10 system. Don't install it for Windows 10 system!

/// RS 232 interface

Configuration:

- > The functions of the interface connections between the device and the automation system are chosen from the signals specified in EIA standard RS 232 in accordance with DIN 66 020 Part 1.
- > For the electrical characteristics of the interface and the allocation of signal status, standard RS 232 applies in accordance with DIN 66 259 Part 1.
- > Transmission procedure: asynchronous character transmission in start-stop mode.
- > Type of transmission: full duplex.
- > Character format: character representation in accordance with data format in DIN 66 022 for start-stop mode. 1 start bit; 7 character bits; 1 parity bit (even); 1 stop bit.
- > Transmission speed: 9600 bit/s.
- > Data flow control: none
- > Access procedure: data transfer from the device to the computer takes place only at the computer's request.

/// Command syntax and format

The following applies to the command set:

- › Commands are generally sent from the computer to the lab device.
- › The lab device only sends at the computer's request. Even fault indications cannot be sent spontaneously from the lab device to the computer (automation system).
- › Commands are transmitted in capital letters.
- › Commands and parameters including successive parameters are separated by at least one space (Code: hex 0x20).
- › Each individual command (incl. parameters and data) and each response are terminated with CR LF (Code: hex 0x0d hex 0x0A) and have a maximum length of 80 characters.
- › The decimal separator in a number is a dot (Code: hex 0x2E).

The above details correspond as far as possible to the recommendations of the NAMUR working party (NAMUR recommendations for the design of electrical plug connections for analogue and digital signal transmission on individual items of laboratory control equipment, rev. 1.1).

The NAMUR commands and the additional specific IKA commands serve only as low level commands for communication between the device and the PC. With a suitable terminal or communications program these commands can be transmitted directly to the device. The IKA software *labworldsoft®*, provides a convenient tool for controlling the device and collecting data under MS Windows.

Commands	Function
IN_PV_2	Read the internal actual temperature.
IN_PV_3	Read the safety actual temperature.
IN_SP_1	Read the internal setting temperature.
IN_SP_3	Read the safety setting temperature.
OUT_SP_1 xxx	Set the internal setting temperature xxx.
OUT_SP_12@n	Set the WD safety temperature with echo of the set (defined) value.
OUT_WD1@n	Start the watchdog mode 1 and set the time for the watchdog to n (20...1500) seconds. Echo of the Watchdog time. During a WD1-event, the tempering (heating / cooling) and pump functions are switched off. The PC 1 warning message will be displayed. This command needs to be sent within the watchdog time.
OUT_WD2@n	Start the watchdog mode 2 and set the watchdog time to n (20...1500) seconds. Echo of the watchdog time. During a WD2-event, the set temperature is changed to the WD safety temperature. The PC 2 warning message will be displayed. This command needs to be sent within the watchdog time.
RESET	Reset the PC control and stop the device functions.
START_1	Start the tempering (heating / cooling) function.
STOP_1	Stop the tempering (heating / cooling) function.

/// Connections between device and external devices

PC 1.1 Cable:

This cable is required to connect RS 232 interface to a PC.

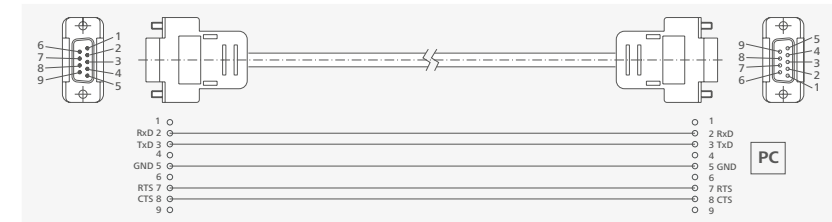

USB 2.0 Cable (A - B):

This cable is required to connect USB interface to a PC.



/// Device software update

Keep your device up-to-date with the IKA Firmware update tool.

The firmware update can be done with a computer connected through USB-Interface.

For this, you need register on our website MyIKA first.

After registering your device IKA will inform you about available updates for your devices. Please download the software "FWUToolSetup.zip" from our IKA service website.

Maintenance and cleaning

To avoid contamination, it is essential to change the bath fluid regularly. If water is used for bath fluid, we recommend to add Water bath protective media. The protective media stops the growth of algae, bacteria and other microorganisms.

To keep the full cooling performance, the dust filter of the cooler must be checked regularly and cleaned if necessary.

- › Switch off the device and disconnect power cable.
- › Take out the dust filter.

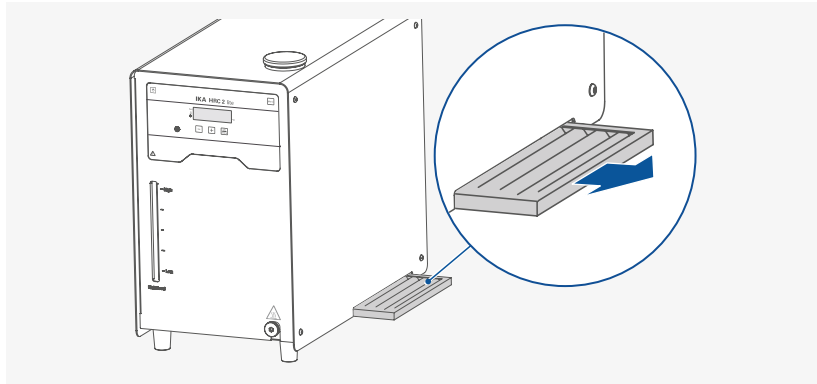

- › Clean condenser dust protection sheet with a vacuum cleaner or wash the sheet in the water and dry the sheet before assembly.

Note: Don't touch the condenser surface with hard parts.

/// Cleaning

For cleaning disconnect the mains plug!

Use only cleaning agents which have been approved by IKA to clean the devices:
Water containing surfactant / isopropyl alcohol.

- › Wear protective gloves during cleaning the devices.
- › Electrical devices may not be placed in the cleansing agent for the purpose of cleaning.
- › Do not allow moisture to get into the device when cleaning.
- › Before using another than the recommended method for cleaning or decontamination, the user must ascertain with IKA that this method does not destroy the device.

/// Ordering spare parts

When ordering spare parts, please indicate:

- › Device type.
- › Serial number, see type plate.
- › Item and designation of the spare part, spare parts diagram and spare parts list.
- › Software version (briefly visible in the display when the device is switched on).

/// Repairs

Please send in device for repair only after it has been cleaned and is free from any materials which may constitute a health hazard.

For repair, please request the "Decontamination Certificate" from **IKA**, or download printout of it from the **IKA** website.

If you require servicing, return the device in its original packaging. Storage packaging is not sufficient. Please also use suitable transport packaging.

Error codes

Any malfunctions during operation will be identified by an error message on the display.

Proceed as follows in such cases:

- › Turn off the device by using the power switch.
- › Carry out corrective measures.
- › Restart the device.

E 11

Causes	› Temperature difference between control sensor and safety sensor is too much.
Effect	› Pump off › Tempering (heating / cooling) function off
Solutions	› Check safety temperature circuit and bath fluid.

E 12

Causes	› Safety temperature alarm.
Effect	› Pump off › Tempering (heating / cooling) function off
Solutions	› Check the bath temperature measurement.

E 13

Causes	› Heater switched off by safety circuit.
Effect	› Pump off › Tempering (heating / cooling) function off
Solutions	› Check safety temperature set value, fluid level.

E 15

Causes	› Safety shutdown of the compressor.
Effect	› Pump off › Tempering (heating / cooling) function off
Solutions	› Check operating conditions according to the "Technical data". › Wait until over-temperatures / -pressures are equilibrated. › Restart the device.

E 16

Causes	› Compressor suction temperature fault.
Effect	› Pump off › Tempering (heating / cooling) function off
Solutions	› Check operating conditions according to the "Technical data". › Wait until over-temperatures / -pressures are equilibrated. › Restart the device.

E 17

Causes	› Compressor discharge temperature fault.
Effect	› Pump off › Tempering (heating / cooling) function off
Solutions	› Check operating conditions according to the "Technical data". › Wait until over-temperatures / -pressures are equilibrated. › Clean the filter.

E 19

Causes	› Fluid temperature too high.
Effect	› Pump off › Tempering (heating / cooling) function off
Solutions	› Check operating conditions according to the "Technical data". › Wait until over-temperatures / -pressures are equilibrated. › Switch the device off and let the fluid cool down.

E 22

Causes	› Motor is not connected
Effect	› Pump off › Tempering (heating / cooling) function off
Solutions	› Send device for repair.

If the actions described fails to resolve the fault or another error code is displayed then take one of the following steps:

- › contact the service department.
- › send the device for repair, including a short description of the fault.

Accessories

/// Tubings, hoses and adapters

LT 5.30	Insulated high temperature hose set (2 x 800 mm), nipples on both sides with M16x1 nuts
LT 5.31	Insulated high temperature hose set (2 x 1200 mm), nipples on both sides with M16x1 nuts
LT 5.32	Insulated high temperature hose set (2 x 1600 mm), nipples on both sides with M16x1 nuts
H.PVC.8	PVC tube (DN 8)
H.PVC.12	PVC tube (DN 12)
H.SI.6	Silicone tube (DN 6)
H.SI.8	Silicone tube (DN 8)
H.SI.12	Silicone tube (DN 12)
H.PUR.8	PUR tube (DN 8)
H.PUR.12	PUR tube (DN 12)
H.FKM.8	FKM tube (DN 8)
H.FKM.12	FKM tube (DN 12)

Hose olive DN 6 (2 pieces)

Hose olive DN 8 (2 pieces)

Hose olive DN 10 (2 pieces)

Hose olive DN 12 (2 pieces)

/// Tubing insulations

ISO. 8	Insulation (DN 8)
ISO.12	Insulation (DN 12)

/// Additional accessories

PC 1.1	Cable (RS 232)
USB 2.0 cable A - B Labworldsoft®	

See more accessories on www.imlab.eu



Technical data

Operating voltage	VAC	230 ± 10 % 115 ± 10 % 100 ± 10 %
Frequency	Hz	50/60
Max. input power	W	1250 (230 VAC) 1000 (115 VAC) 820 (100 VAC)
Fuse		T 10 A 250 V (2 x)
Working temperature range	°C	- 10 ... + 100
Operating temperature range	°C	- 10 ... + 100
Temperature stability – internal temperature control 70°C, water (according to DIN 12876)	K	± 0.05
Temperature stability – internal temperature control -10°C, ethylene glycol (according to DIN 12876)	K	± 0.1
Temperature control		PID
Temperature setting		Buttons
Temperature setting resolution	K	0.1
Temperature display		LED
Temperature display resolution	K	0.1
Classification according to DIN 12876		Class II (FL) suitable for flammable and non-flammable fluids
Safety circuit (adjustable)	°C	0 ... + 110
Safety temperature display		LED
Heating capacity	W	1000 (230 VAC) 750 (115 VAC) 570 (100 VAC)
Cooling capacity according to DIN 12876:		
+ 20 °C	W	400
+ 10 °C		350
0 °C		250
- 10 °C		100
Refrigerant		R 290
Refrigerant quantity	g	79
Max. refrigerating system pressure	bar	21
Max. pump pressure / suction	bar	0.35/0.15
Max. flow rate (at 0 bar)	l/min	18
Bath volume	l	1 ... 3.5
Fluid maximum viscosity	mm ² /s	50
Interface		USB, RS 232
Permitted on-time	%	100
Noise level	dB (A)	51
IP code according to EN 60 529		IP 21
Protection class		I
Overvoltage category		II

Contamination level		2
Permissible ambient temperature	°C	+5 ... +32
Permissible relative humidity	%	80
Dimensions (W × D × H)	mm	225 × 430 × 385
Weight	kg	24.9
Operation at a terrestrial altitude	m	max. 2000

Note: Refrigerant must be disposed of in accordance with local and national regulations.

Subject to technical changes!

Warranty

In accordance with IKA warranty conditions, the warranty period is 24 months. For claims under the warranty please contact your local dealer. You may also send the machine direct to our factory, enclosing the delivery invoice and giving reasons for the claim. You will be liable for freight costs.

The warranty does not cover worn out parts, nor does it apply to faults resulting from improper use, insufficient care or maintenance not carried out in accordance with the instructions in this operating manual.

Pump performance curve

Pump performance curve measured with water:

(Measurements done according DIN 12876-2 with water at 20 °C; pump in a closed-loop circuit).

