

IKA

designed for scientists

IC control
HBC 5 control
HBC 10 control



Operating instructions

EN

IC control, HBC 5 control, HBC 10 control:

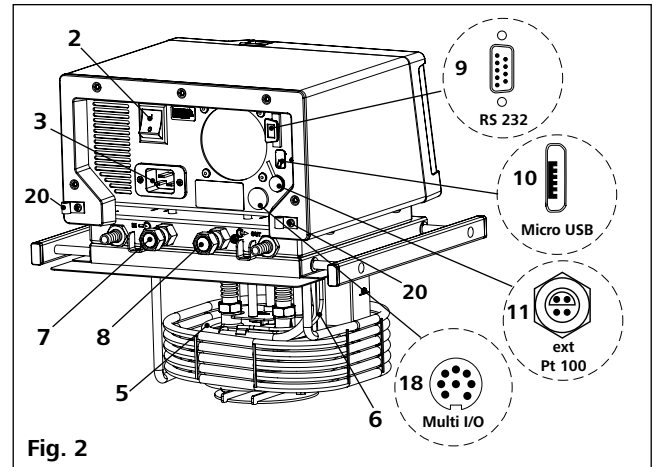
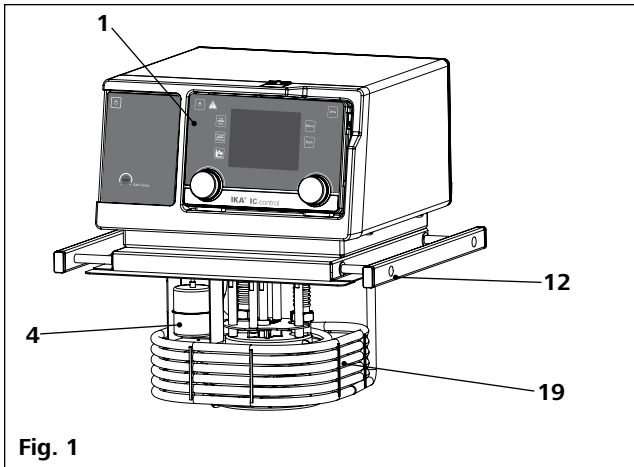

HBC 5 control, HBC 10 control:

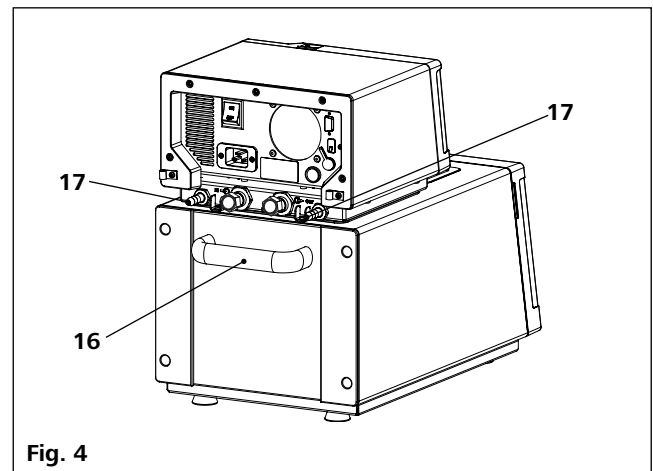
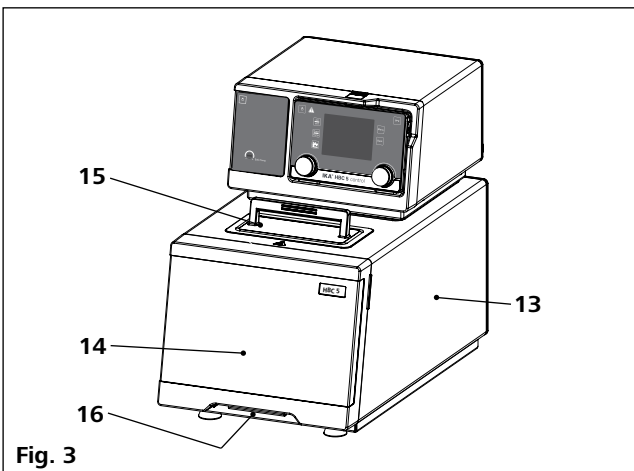

Item	Designation
1	Wireless Controller (WiCo)
2	Power switch
3	Power socket
4	Buoyage
5	Heater
6	Pt 100 + Pt 1000 temperature sensor
7	Pump connection IN
8	Pump connection OUT
9	RS 232 port
10	USB port
11	External temperature sensor socket
12	Bridge (only for IC control)
13	Bath
14	Front cover
15	Filling lid
16	Handle
17	Connection cooling coil (only HBC control)
18	Multifunction terminal
19	Cooling coil
20	Cable clip

Contents

	Page
EU Declaration of Conformity	4
Note for USA (FCC)	4
Note for Canada (IC)	4
Explication of warning symbols	4
Safety instructions	5
General information	5
Fluid	6
Battery pack RB 1 (for Wireless Controller)	6
Intended use	8
Use	8
Range of use	8
Wireless remote control.....	8
Unpacking	8
Unpacking	8
Delivery scope	8
Preparations	9
Setting up	9
Connecting the tubings	9
Filling and draining	9
Fluid (Standard information for IKA fluid)	11
Cooling coil	12
Charging the Battery Pack RB 1 (rechargeable battery)	12
Changing battery to WiCo	12
WiCo – holder WH 10	12
Operator panel and display	13
Station (IC station/HBC station)	13
Wireless Controller (WiCo)	13
Commissioning	14
Setting the safety temperature	15
Useful information	15
Working with Wireless Controller (WiCo)	16
Working screen at the time of delivery.....	16
Explanation of symbols on the working screen.....	16
Menu navigation and structure	17
Menu (Details).....	19
Interface and output	24
Maintenance and cleaning	27
Error codes	27
Accessories	28
Technical data	29
Warranty	30
Pump performance curve	30

EU Declaration of Conformity

We declare under our sole responsibility that this product corresponds to the regulations 2014/35/EU, 2006/42/EC, 2014/30/EU and 2011/65/EU and conforms with the standards or other normative documents: EN 61010-1, EN 61010-2-010, EN 61326-1, EN 60529, EN ISO 12100 and DIN 12876-1, -2, -3.

Bluetooth® module:
Directive: 1999/5/EC

Standards: EN 60950-1, EN 300328, EN 301489-17

A copy of the complete declaration of conformity or further declarations of conformity can be requested.

Note for USA (FCC)

This equipment complies with Part 15 of the FCC rules. Any changes or modifications not expressly approved by the Manufacturer could void the user's authority to operate the equipment. This device complies with Part 15 of the FCC rules subject to the following two conditions:

- (1) This device may not cause harmful interference, and
- (2) This device must accept all interference received, including interference that may cause undesired operation.

NOTE:

This equipment has been tested and found to comply with the limits for a Class B digital device, pursuant to part 15 of the FCC Rules. These limits are designed to provide reasonable protection against harmful interference when the equipment is operated in a commercial environment.

This equipment generates, uses, and can radiate radio frequency energy and, if not installed and used in accordance with the instruction manual, may cause harmful interference to radio communications. Operation of this equipment in a residential area is likely to cause harmful interference in which case the user will be required to correct the interference at his own expense.





Note for Canada (IC)

This device complies with Industry Canada license-exempt RSS standard(s). Operation is subject to the following two conditions:

- (1) This device may not cause interference
- (2) This device must accept any interference, including interference that may cause undesired operation of the device.

This device complies with Health Canada's Safety Code 6/IC RSS-210. The installer of this device should ensure that RF radiation is not emitted in excess of the Health Canada's requirement.

Explication of warning symbols

 DANGER	Indicates an (extreme) hazardous situation, which, if not avoided, will result in death, serious injury.
 WARNING	Indicates a hazardous situation, which, if not avoided, can result in death, serious injury.
 CAUTION	Indicates a potentially hazardous situation, which, if not avoided, can result in injury.
 NOTICE	Indicates practices which, if not avoided, can result in equipment damage.
 CAUTION	Reference to exposure to a hot surface.

Safety instructions

General information:

- **Read the operating instructions completely before starting up and follow the safety instructions.**
- Keep the operating instructions in a place where it can be accessed by everyone.
- Ensure that only trained staff work with the device.
- Follow the safety instructions, guidelines, occupational health, safety and accident prevention regulations.
- Set up the device in a spacious area on an even, stable, clean, non-slip, dry and fireproof surface.



Do not use the device in explosive atmospheres, it is not EX-protected.



With substances capable of forming an explosive mixture, appropriate safety measures must be applied, e.g. working under a fume hood.



To avoid body injury and property damage, observe the relevant safety and accident prevention measures when processing hazardous materials.

- Protect the device and accessories from bumping and impacting.
- Check the device and accessories for damage before each use. Do not use damaged components.
- Safe operation is only guaranteed with the accessories described in the "Accessories" section.
- The socket for the mains cord must be easily accessible.
- Socket must be earthed (protective ground contact).
- The voltage stated on the type plate must correspond to the mains voltage.
- The device can only be disconnected from the mains supply by pulling out the mains plug or the connector plug.
- Disconnect the mains plug before attaching or changing any accessories.
- Disconnect the mains plug before cleaning, maintenance or moving the circulator.
- The device must only be opened by trained specialists, even during repair. The device must be unplugged from the power supply before opening. Live parts inside the device may still be live for some time after unplugging from the power supply.



Coverings or parts that can be removed from the device without the aid of any tools must be put back on the device again to ensure safe operation, for example to keep foreign objects and liquids, etc. from getting into the device.

- The device may only be used as prescribed and as described in the operating instructions. This includes operation by instructed specialist personnel.
- When using critical or hazardous materials in your processes, **IKA** recommends to use additional appropriate measures to ensure safety in the experiment. For example, users can implement measures that inhibit fire or explosions or comprehensive monitoring equipment.
- Process pathogenic material only in closed vessels under a suitable fume hood. Please contact **IKA** application support if you have any question.



If the **OFF** switch is not within reach when device is operating, an **EMERGENCY STOP** switch that can be easily accessed must be installed in the work area.

- A laboratory circulator heats and circulates fluid according to specified parameters. This involves hazards due to high temperatures, fire and general hazards due to the device of electrical energy. The user safety can not be ensured simply with design requirements on the part of the device. Further hazard sources may arise due to the type of tempering fluid, e.g. by exceeding or undercutting certain temperature thresholds or by the breakage of the container and reaction with the heat carrier fluid. It is not possible to consider all eventualities. They remain largely subject to the judgment and responsibility of the operator. For this reason, it may become necessary for user to take other precautionary safety measures.
- Insufficient ventilation may result in the formation of explosive mixtures. Only use the device in well ventilated areas.



The safety circuit (safe temperature) must be adjusted so that the maximum permissible temperature cannot be exceeded even in the event of a fault. Check the safe temperature circuit on a regular basis.

- Securely fix the **IC control** immersion circulator for use at the bath, so that it cannot tip over.
- When device is used for external circulation, extra precaution must be taken for hot fluid leakage due to damaged hose.
- Use suitable hoses for connection.
- Secure hoses and tubes against slippage and avoid kinks.
- Check hoses, tubes and bath at regular intervals for possible material fatigue (cracks/leaks).
- Mains cable should not get in contact with hot parts and fluids.
- If you are using plastic bath, observe the permitted working temperature range and fluids.

 **DANGER**

Do not start up the device if:

- It is damaged or leaking
 - Cable (not only supply cable) is damaged.
- Be careful when filling a hot bath.

 **CAUTION**

At high operating temperatures, the temperature of housing parts, surfaces and tubes can exceed 70 °C.

 **CAUTION**

It is dangerous to touch the heater. The temperature of the heater can be very high.

- After a power failure during operation, the device may start automatically (depending on operating mode).
- Transport the device with care.
- Do not transport or empty the bath while it is still hot. This may result in accidents, especially scalding injuries.

 **NOTICE**

IC control: In order to prevent the power cord fall into the medium, the mains cable should be always be secured with the cable clips (20, see Fig. 2).

Fluids:

 **CAUTION**

Beware of the risk of burning due to delay in boiling!

 **WARNING**

Only use fluids, which fulfill the requirements for safety, health and device compatibility. Be aware of

the chemical hazards that may be associated with the bath fluid used. Observe all safety warnings for the fluids.

- Depending on the bath fluid used and the type of operation, toxic or flammable vapors can arise. Ensure suitable extraction.
- Do not use any fluid which may cause dangerous reactions during processing.
- Only use recommended bath fluid. Only use non-acid and non corroding fluid.

 **WARNING**

The safety temperature must be set in accordance with EN 61010-2-010 chapter "Requirements for equipment containing or using flammable liquids".

- The surface temperature of the flammable medium that is exposed to air should not exceed its flash point. A danger usually arises if a medium is heated in open vessels.

- The surface temperature of the heating element (e.g. the heating plate of a magnetic stirrer and/or the heater of a thermostat) at the surface of the flammable medium and in contact with air should not exceed the value of $(t - 25)$ °C (= set value of the safety circuit), whereby **t** is the fire point of the medium. In case of uncertainties regarding the fire point, we recommend using the lower flash point as **t**.

A danger usually arises if a medium is heated in glass vessels (glass breakage).

- If a setting made by the user (medium temperature or safety temperature) could bring a flammable medium into a state in which the conditions mentioned above could be exceeded, additional measures must be introduced that will protect the user from this danger.
- Examine regularly the function of the safety temperature limiter.

 **NOTICE**

Never operate the device without sufficient heat carrier fluid! You should also be careful to ensure that the minimum clearances and immersion depths in the fluid are observed. Check the fluid level detection at a regular basis (see section "Filling and draining").

- Continuous monitoring of the bath and the filling level of the bath fluid is required, especially at high temperatures.
- To ensure a sufficient fluid circulation, the viscosity of the bath fluid must not exceed of 50mm²/s at the lowest operating temperature.

 **NOTICE**

If water is used at higher temperature, there is heavy loss of fluid due to the evaporation.

- Untreated tap water is not recommended. It is recommended to use distilled water or high purity water (ion exchangers) and add 0.1 g soda (sodium carbonate Na₂CO₃) /liter, to reduce corrosive properties.

 **CAUTION**

Risk of burning caused by vapor or hot water at the outlet of the cooling coil.

 **NOTICE**

Do not use the cooling coil with water at bath temperatures > 95° C.

 **NOTICE**

For bath temperatures > 60°C make sure that the flow rate through the cooling coil is high enough.

 **NOTICE**

Don't use following fluids:

- Untreated tap water
- Acids or bases
- Solutions with halides: chlorides, fluorides, bromides, iodides or sulfur
- Bleach (Sodium Hypochlorite)
- Solution with chromates or chromium salts
- Glycerine
- Ferrous water.

 **NOTICE**

When changing the bath fluid from water to a heat transfer fluid for temperatures above

100 °C, remove the remaining water from the complete system (including hoses and external devices). When doing this, also open the stopper and union nuts caps of the pump outputs and inputs and blow compressed air through all the pump outputs and inputs! Beware of the risk of burning due to delay in boiling!

Battery pack RB 1 (for Wireless Controller):

 **NOTICE**

If during operation the **battery pack RB 1** (rechargeable battery) becomes fully discharged, the device (**Station**) will continue to run or is shut down depending on the value settings for "Time Out", "Safe Speed" and "Safe Temperature". If the device is set so that it continues to run when the battery of the Wireless Controller (WiCo) is fully discharged, the only means of switching the station off are the "safe STOP", "ON/OFF" key and the "Mains switch"!

 **NOTICE**

Please note the following safety instructions for the battery pack RB 1 (rechargeable battery):

- Keep the battery pack out of reach of children at all times.
- Store the battery pack in a cool, dry place.
- Never throw the battery pack into a fire. Keep it away from direct sunlight and temperatures above 60 °C. High temperatures will damage the battery pack and render it unusable. Temperatures above 100 °C may cause it to explode.
- Never throw the battery pack into water or expose it to moisture. Water may lead to a short-circuit, causing the battery pack to explode.

- Do not deform or crush the battery pack or damage it in any other way. This can cause battery fluid to leak and/or the battery pack to explode.
- When not in use, keep battery packs away from paperclips, coins, keys, nails, screws or other small metal objects which could cause the contacts to be bridged. Short-circuiting may result in an explosion.
- Explosion of a battery pack may release battery fluid and cause a fire.
- The lithium polymer battery pack must only be used and charged in **IKA** products designed for use with this battery pack.
- When the battery pack is inserted it should slide in easily and without resistance. Do not force it.
- If the battery pack is removed for an extended period of time, store it in a sealed plastic bag to prevent short-circuiting due to moisture or contact with metal components.
- The operating temperature range of the battery pack is from 0 °C to + 45 °C. Note that the battery pack capacity will be reduced at temperatures below 20 °C.
- Only the rechargeable battery types recommended in the technical data may be used in the device!

 Do not charge batteries that have leaked or that are discolored, deformed or damaged in any other way.

Disposal instructions:

- When disposing of the **IKA** battery pack, please tape over the contacts with adhesive tape to prevent short-circuiting due to moisture or contact with metal components. Short-circuiting may result in an explosion.
- Do not throw used battery packs into your household waste. Dispose of them properly in accordance with statutory regulations.

 End users are obliged by law to return all used disposable and rechargeable batteries. Throwing them into the household waste is prohibited. Disposable/rechargeable batteries containing harmful substances are marked with this symbol to indicate that they may not be disposed of as household waste.

- You can return used disposable and rechargeable batteries free of charge to your local authority collection site or to any battery retailer. In doing so you will be complying with statutory regulations and helping to protect the environment.
- Batteries must be disposed of in accordance with local and national regulations.

Intended use

Use:

Use **IC** (Immersion Circulator) and **HBC** (Heating Bath Circulator) for heating and circulating fluids

Intended Use: tabletop device

Range of use:

Indoor environments similar to that a laboratory of research, teaching, trade or industry.

Wireless remote control:

Before using the wireless link between the **Wireless Controller (WiCo)** and the laboratory device, first check whether your region is included in the radio communication approval for the device. If it is not, remote control can also be performed using a USB cable.

The safety of the user cannot be guaranteed:

- If the device is operated with accessories that are not supplied or recommended by the **IKA**.
- If the device is operated improperly or in contrary to the **IKA** specifications.
- If the device or the printed circuit board are modified by third parties.

Unpacking

Unpacking:

- Please unpack the device carefully
- In the case of any damage a detailed report must be sent immediately (post, rail or forwarder).

Note: Transport safety:

Remove the transport protection under the buoyage (4). For **HBC** device, you need to open the lid (15) and remove the protection.

Delivery scope:

IC control, HBC control, HBC 10 control:

- **IC control** or **HBC 5 control** or **HBC 10 control** with the **Wireless Controller (WiCo)** according to the order
- Mains cables
- Hose olive DN 12 (2 pieces) see Fig. 5
- Screwdriver (use for safety circuit) see Fig. 6
- **WiCo** holder **WH10**
- **OS 1.0** power supply (for **WiCo**) see Fig. 7
- **RB 1** Battery pack
- USB 2.0 cable Micro A – Micro B
- USB 2.0 cable A – Micro B
- User guide
- A warranty card.

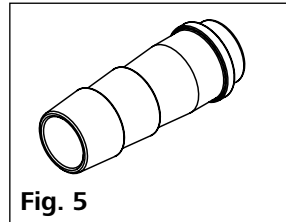

Fig. 5

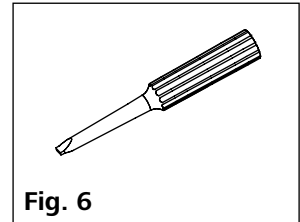

Fig. 6

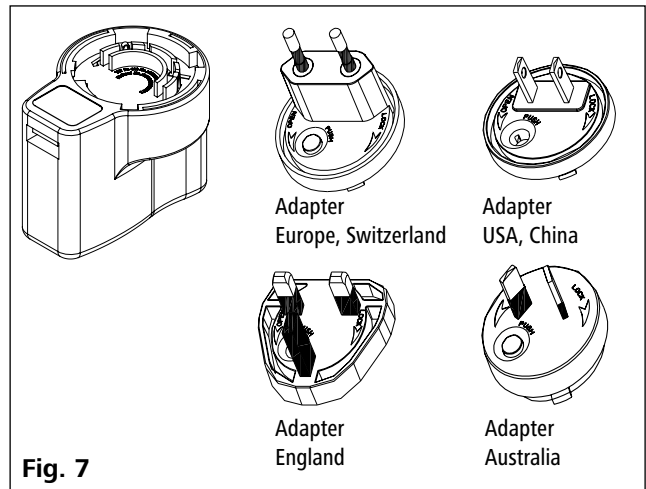

Fig. 7

Preparations

Setting up:

- Place the device on an even, stable, clean, nonslip, dry and fireproof surface.
- Keep at least 20 cm of open space at the front and rear side.
- When a plastic bath is used, please ensure that the heater does not contact the bath.
- The place for installation should be large enough and provide sufficient air ventilation to ensure the room does not warm up excessively because of the heat from device radiates to the environment.
- Do not set up the device in the immediate vicinity of heat sources and do not expose to sun light.

Connecting the tubings:

- Unscrew the union nuts and stoppers using a wrench from the pump connection IN (7) and OUT (8).

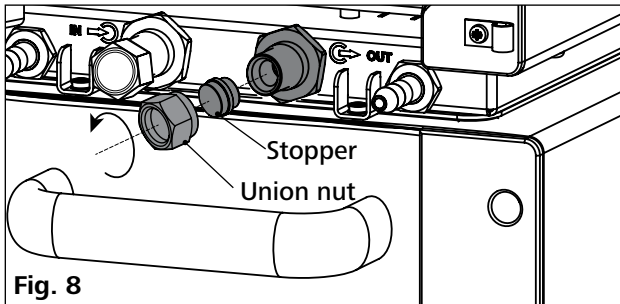

Fig. 8

- Connect the hoses for circulating the external system to the pump connectors M 16 x 1 for IN and OUT directly or with the olives.
- Screw the hose olive to the pump connection IN and OUT with union nuts. Slide the hoses (NW 12) onto the olives. The hoses must be secured with suitable clamps.

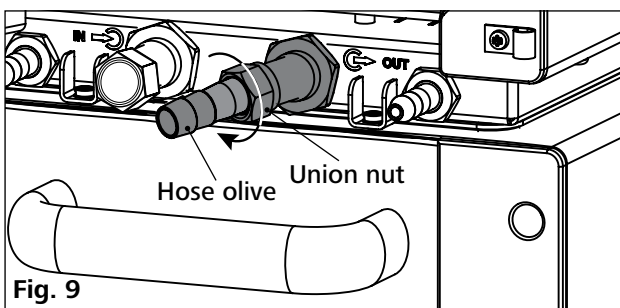

Fig. 9

Note: Please note the permissible temperature range of hoses. For hot fluids we recommend the IKA **LT 5.20** hoses. When the external system is not necessary, please seal the pump connectors IN and OUT with the existing union nuts and stoppers.

Filling and draining:

- Before filling the fluid into the bath, open the front cover as indicated in following figure.

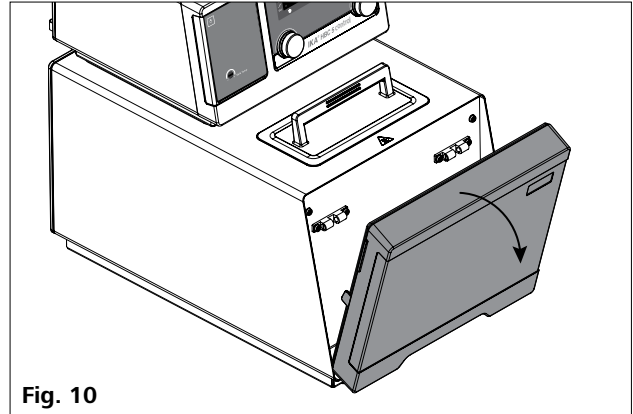

Fig. 10

- Check and make sure that the drain valve is closed (the stop position in clockwise direction, see Fig. 11).

Note: Please note information in chapter "Commissioning".

- Connect the mains plug and turn on the device with power switch (2).
- The low level icon (☹) appears on the display of the **Wireless Controller (WiCo)**.
- Open the lid (15) and fill fluid to the bath.

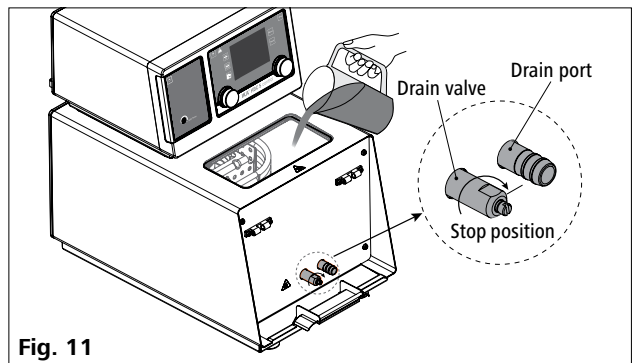

Fig. 11

Note: Pay attention to the fluid level information on the display:

- ☹ — Low level
- ☺ — High level

(see "Fluid level" in section "Working with Wireless Controller (WiCo)").

- To drain the fluid from the bath, connect a hose to the drain port and turn the drain valve in counter clockwise direction with a straight screwdriver.

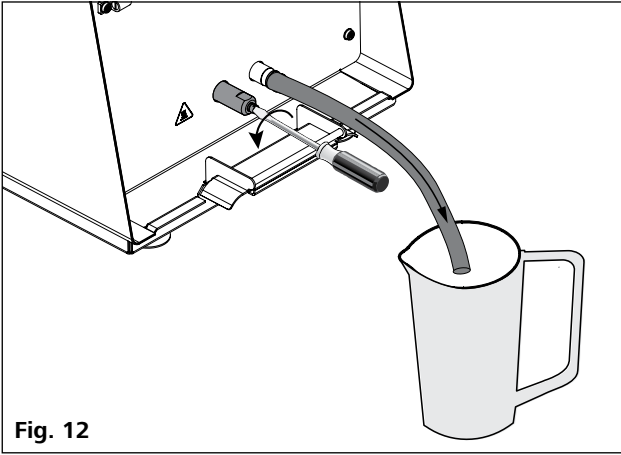

Fig. 12

Fluid (Standard information for IKA fluid):

IKA Designation	Operating temperature range for open bath application (°C)	Operating temperature range for closed bath applications (°C)	Safety temperature (°C)	Flash point (°C)
CF.EG28.N10.80.8	-10 ... 80	-10 ... 80	90	115
CF.EG39.N20.80.16	-20 ... 80	-20 ... 80	90	115
CF.EG44.N25.80.19	-25 ... 80	-25 ... 80	90	115
CF.EG48.N30.80.22	-30 ... 80	-30 ... 80	90	115
UF.Si.N30.150.10LV	-30 ... 130	-30 ... 150	145 1	>170
HF.Si.20.200.50	20 ... 200	20 ... 200	255	>280
HF.Si.20.250.50A	20 ... 200	20 ... 250	255	>280
H ₂ O (Water) 2	5 ... 95	5 ... 95	-	-
Customized 1 3				
Customized 2 3				

Check the suitability of the fluid according to your application.

Nomenclature for IKA fluid:

CF.EG28.N10.80.8 --

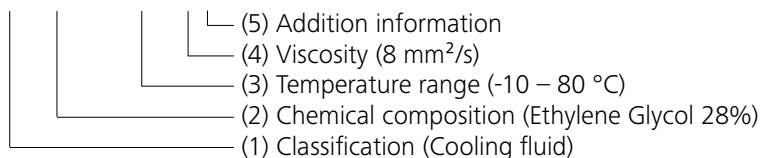

(1) Classification:

HF: Heating Fluid
 CF: Cooling Fluid
 UF: Universal Fluid

(2) Chemical composition:

Si: Silicone oil
 EG: Ethylene Glycol

(3) Temperature range: (Minimum temperature. Maximum temperature)

N: Negative Temperature

(4) Viscosity:

Viscosity at 25 °C for Heating Fluid (HF)
 Viscosity at -20 °C for Cooling Fluid (CF)
 Viscosity at 25 °C for Universal Fluid (UF)

Dynamic viscosity [mPa.s] is a product of kinematic viscosity [mm²/s] and density [kg/m³] of the fluid divided by 1000.

(5) Additional information:

A: Oil Additives
 LV: Low Viscosity

1 Note: for open bath application!

2 Note: Tap water may be unsuitable for operation because the calcium carbonate content may cause calcification. High purity water (from ion exchangers) and distilled or bi-distilled water are unsuitable for operation due to corrosive properties of these media. High purity water and distillates are suitable as a medium after adding 0.1 g soda (Na₂CO₃, sodium carbonate) per liter of water.

3 Note: The temperature limit values are adjustable in accordance with the fluid used.

Cooling coil:

When the set temperature close to the ambient temperature, the cooling coil should be used for counter-cooling due to the self-heating.

Connect the water supply and return line hoses to the cooling coil connectors (see Fig. 2).

For bath temperatures > 95 °C do not use the cooling coil with water.

For bath temperatures > 60 °C make sure that the flow rate through the cooling coil is high enough, to avoid excessive calcification.

Charging the Battery Pack RB 1 (rechargeable battery):

The battery pack of the **WiCo** can be charged by any of the following means:

- On the **station**
- Via a USB cable at the PC or **station**
- Via an **OS 1.0** power supply unit.

Changing battery to WiCo:

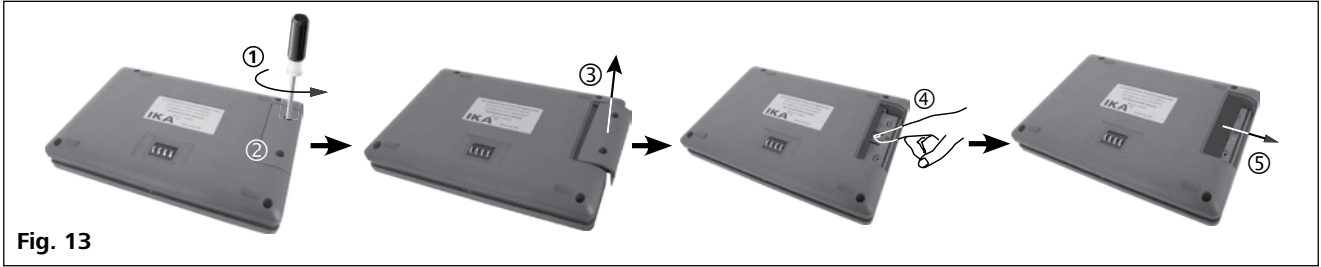

NOTICE

Please comply with the relevant safety instructions in the "Safety instructions" section for the RB 1 battery pack!

WiCo – holder WH 10:

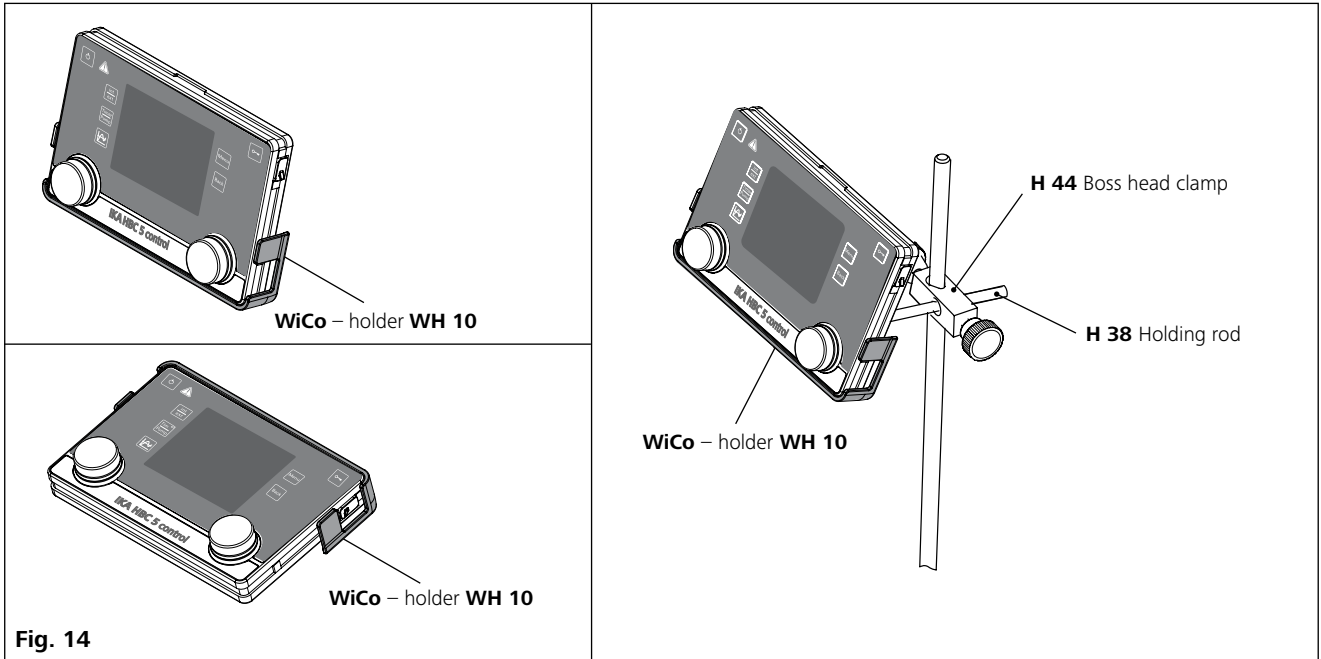

Operator panel and display

station (IC station/HBC station):

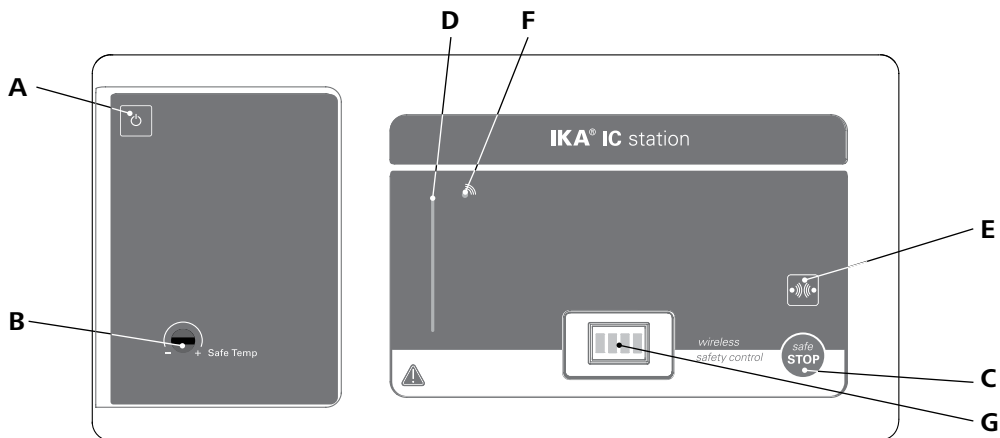

Fig. 15

Item	Designation	Function
A	ON/OFF button:	Switch on/off the station .
B	Adjustable safety circuit:	Adjust the safety temperature limit with delivered screwdriver.
C	"safe STOP" button:	Safe stop the working of the circulator in emergency.
D	LED bar:	Display different status of the circulator with different color.
E	Bluetooth® searching button:	Search the Wireless Controller (WiCo) when the Bluetooth® is active.
F	Bluetooth® LED:	Bluetooth® indicator.
G	Contacts:	Communicate and charge the WiCo .

Wireless Controller (WiCo):

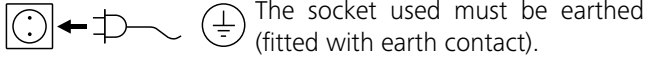

Fig. 16

Item	Designation	Function
J	Rotating/pressing knob:	Navigation, selecting and changing the settings in the menu Set the pump speed value Start/Stop the pump function
K	Rotating/pressing knob:	Set the temperature value Start/Stop the heating function
L	ON/OFF button:	Switch the WiCo on and off
M	"Menu" button:	Press it once: main menu is displayed Press it a second time: back to the working screen
N	"Back" button:	Return to the previous menu level
O	Key button:	Lock/Unlock the knobs and keys
P	"int/ext" button:	Switch between the internal and external temperature display and control
R	"Timer/Pump" button:	Switch between the timer and pump display
S	Graph button:	Display time/temperature graph

Commissioning

Check whether the voltage given on the type plate corresponds to the available mains voltage.



The socket used must be earthed (fitted with earth contact).

If these conditions have been met, the machine is ready for operation when the mains plug is plugged in. If these conditions are not met, safe operation is not guaranteed and the machine could be damaged.

Observe the ambient conditions (temperature, humidity, etc.) listed under "Technical Data".

The battery in the **Wireless Controller (WiCo)** must be charged at the **station** before the first use of the device.

Mounting the Wireless Controller to the station:

Put the **WiCo** into the holder at the **station** while pressing the release button.

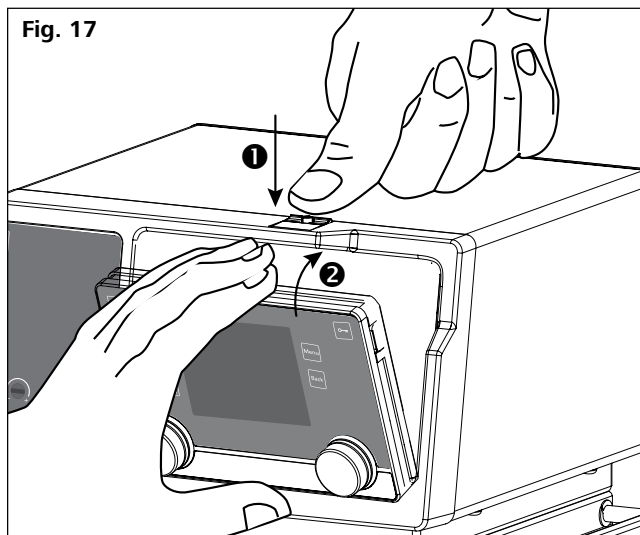

If the **WiCo** should be permanently attached to the **station**, we strictly recommend to fasten the unlocking button with the integrated screw (turn counter clock wise).

After switch on the power switch (2) at the rear side of the **station**, the screen of the **WiCo** displays the device designation and the software version after a beep.



Fig. 18

After several seconds, screen display the information of **WiCo**.

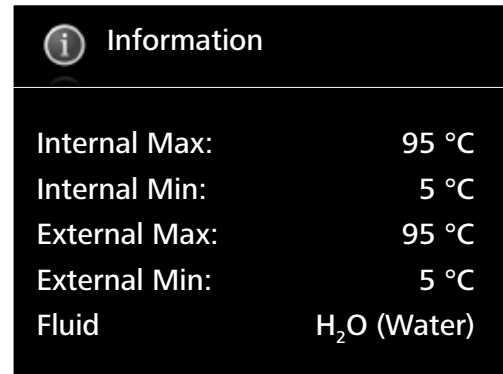

Fig. 19

Then the working screen in standby status appears and the device is ready for operation.

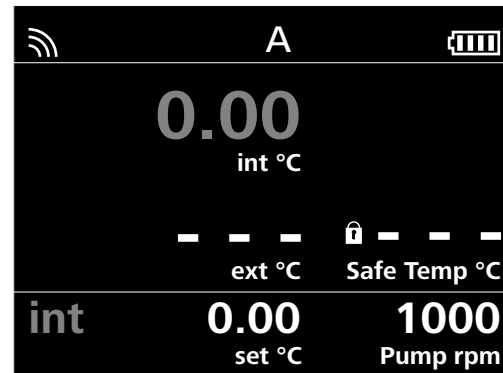

Fig. 20

Change the temperature setting with left knob (K). Change the pump speed setting with the right knob (J). In standby status, press the left knob (K). The device starts heating function and the pump begins to run. In work status, press the right knob (J) to stop operation of the pump. The heating function and the pump stops.

Note: In standby status, press the right knob (J) to start the pump function, the heating function will not be activated. In working status, press the left knob (K) to stop the heating function, the pump keep running.

When the **WiCo** is switched on without being connected to the **station**, the green LED bar (D) and the green Bluetooth® LED (F) on circulator lights up.

The controls of the **WiCo** allow locked by pressing the key button (O), so no accidental changes during operation are possible (key symbol appears in the display). By pressing the key button (O) again, the controls are released (key symbol disappears from the display).

Note: In an emergency, the device functions can be turned off by pressing the "safe STOP" button (C) at the front of the **station**. The LED bar (D) changed from green color into red color.

A message appears in the display indicates that the **station** was forced off. To restart, press the "ON/OFF" (A) or the mains switch (2) off and on.

If the Bluetooth® function of the **WiCo** is activated, the Bluetooth® icon  appears on the screen and the user can search the **WiCo** by pressing the searching key (E). Then, a beep is heard.

Setting the safety temperature

Adjust the safety temperature with screwdriver included with the device.

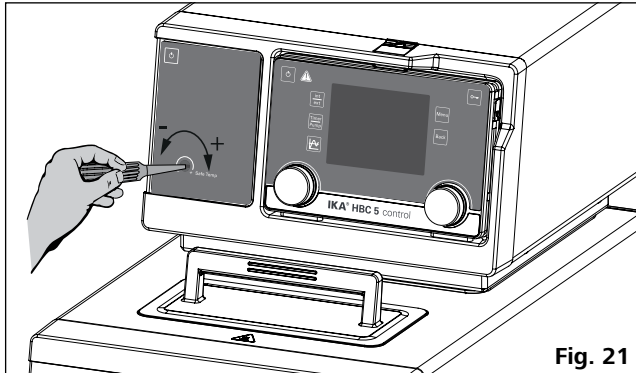

Fig. 21

The safety temperature setting will appear on the display.

Factory setting: maximum value
Adjustment range: 0 – 260 °C

WARNING

The safety temperature must always be set to at least 25 °C lower than the fire point of the fluid used. In case of uncertainties regarding the fire point, we recommend setting the safety temperature to a least 25 °C lower than the flash point of the fluid used.

Useful information

The **station** is controlled via a **Wireless Controller (WiCo)**. If the **WiCo** is mounted on the **station**, data is exchanged between the **station** and **WiCo** via the contacts (G). The screen of the **WiCo** displays the home icon .

The **WiCo** is equipped with a USB socket (Universal Serial Bus) with which the **WiCo** can be connected with **station**, the USB icon  appears on the screen.

If the **WiCo** is not connected with the **station** via a USB cable, the data exchange between the **station** and the **WiCo** via Bluetooth®. In this case, the Bluetooth® icon  is displayed .

Depending on the structure of the building, the **Wireless Controller** can be operated at a distance up to 15 m from the **station**, using the Bluetooth® connection.

The **WiCo** could be either installed on the **station** or put on a safe place where is accessed easily by the user during operation.

If the **WiCo** is mounted on the **station**, the battery is charged through the contacts (G).

The battery could also be charged via the USB socket on the **Wireless Controller** (See "Charging the Battery Pack RB 1 (rechargeable battery)" in "Preparations" section).

Working with Wireless Controller (WiCo)

Working screen at the time of delivery:

The start and information screen (see section "Commissioning") appears for a few seconds after the **WiCo** is switched on. After this, the following working screen appears automatically in the display.

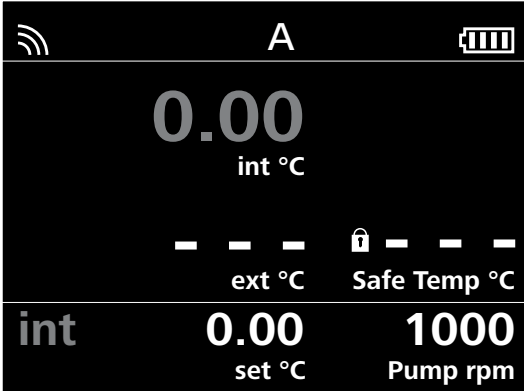

Fig. 22

Note: The wireless symbol  appears only when the **station** is switched on.

Explanation of symbols on the working screen:

The symbols displayed change depending on the status and settings of the **WiCo** and the **station**. The screen below shows the most significant symbols on the working screen.

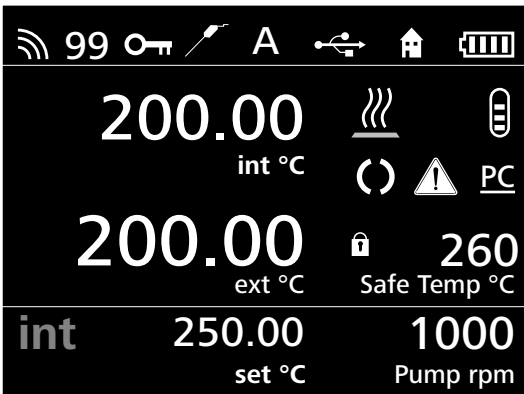

Fig. 23

Bluetooth®:

This symbol means the **station** and the **WiCo** are communicating via Bluetooth®.

The symbol no longer appears if no Bluetooth® communication is being performed.

99 Device number:

This figure appears when the "Device Number" is activated in menu option "Display".

The figure can be set from 0 to 99.

See section "Display" under "Menu (Details)".

Lock:

This symbol means that the function of the keys and the rotary knobs for controlling the **WiCo** are disabled.

The symbol no longer appears if the functions are enabled once again by pressing the key button a second time.



Temperature Sensor:

This symbol appears when the external temperature sensor is connected.

A Operating Mode:

This symbol indicates the operating mode currently selected (A, B, C or D).



USB:

This symbol means the **WiCo** is communicating or the battery is charged via a USB cable. The symbol no longer appears if no USB cable is being used for communicating with the **station**.



Home:

This symbol means that the **WiCo** is connected to the **station** and is communicating with the **station** via the **contacts**.

The symbol no longer appears if the **WiCo** is removed from the **station**.



Battery pack:

This symbol indicates the charging status of the **RB 1 battery pack** within the **WiCo**.



The charging symbol appears if the **WiCo**

- Is connected to a PC via a USB cable
- Is connected to a Circulation **station** via a USB cable
- Is connected to the power supply unit **OS 1.0** via a USB cable
- Is connected to the **station** via the charger contacts.



Heating

This symbol indicates that the heating function is active.

 →  →  indicate active heating process.



Fluid level

This symbol indicates fluid level.

The red symbol  means the fluid is above the maximum fluid level. Excess fluid should be drained out.

The red symbol  means the fluid is below the minimum fluid level. Please add fluid.



Pump:

This symbol indicates that the pump is activated.



Warning:

This symbol indicates that warning is active.



PC Control:

This symbol means that either the **station** or the **WiCo** is connected to a computer and is being controlled from the computer.



Program Control:

This symbol indicates that the **WiCo** is controlled by a program (see "PROGRAMS").

Menu navigation and structure:

Menu navigation:

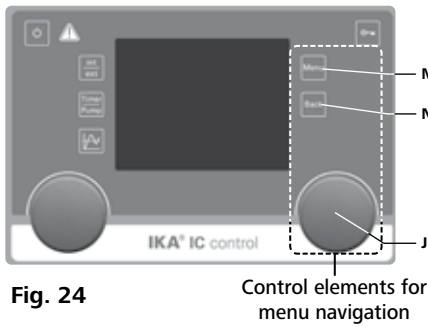

- Press the "Menu" key (M).
- Select the menu by turning the right rotating/pressing knob (J) to the right or left.
- Open the menu item by pressing the right rotating/pressing knob (J).
- Turn the rotating/pressing knob (J) to select the desired menu option and edit the values or settings.
- Press the rotating/pressing knob (J) to get into sub menu items to active/inactive to switch settings or to confirm settings ("OK").
- Press the "Back" button (N) to a setting or cancel to return to the previous menu.
- Press the "Menu" button (M) to return directly to the working screen.

Note: When the tempering or pump functions are active, the menu is locked. On the display, the active menu option is highlighted in yellow. The active status of a menu item is marked with a check (✓).

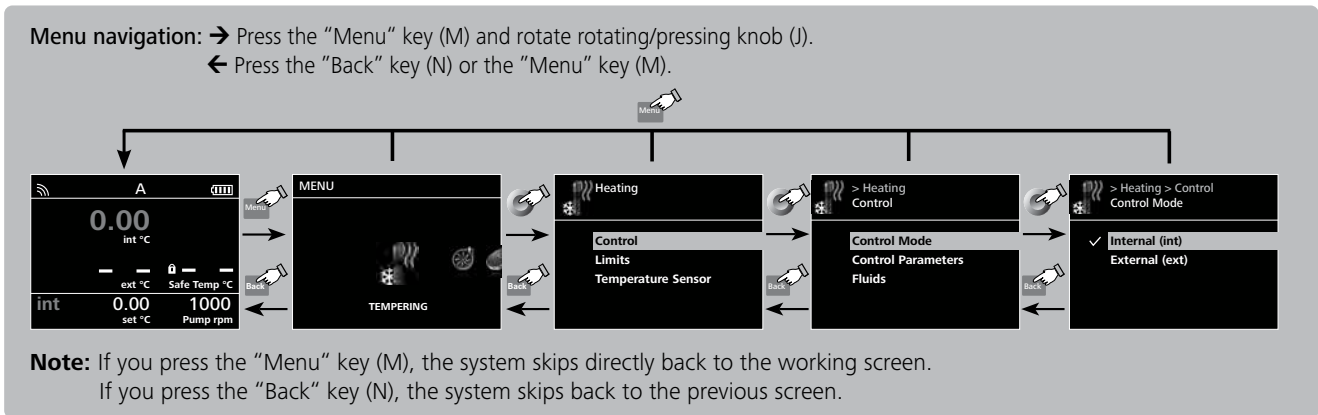

Fig. 25

Menu structure:

		Factory Settings		
TEMPERING	Control	Control Mode	Internal (int) activated	
		External (ext) -		
		Control Parameters	Automatic	Accurate activated
			Fast -	
		Manual	Internal (Kp, Ti, Td, Ts, Prop_Bp, Prop_Bn) 60.0, 5.0, 0.3, 3s, +1.00K, -1.00K	
			External (Kp, Ti, Td, Ts, Prop_Bp, Prop_Bn) 1.0, 15.0, 0.0, 90s, +1.00K, -1.00K	
		Information (Kp, Ti, Td, Ts, Prop_Bp, Prop_Bn) yes		
		Fluids	CF.EG28.N10.80.8 -	
			CF.EG39.N20.80.16 -	
			CF.EG44.N25.80.19 -	
	CF.EG48.N30.80.22 -			
	UF.Si.N30.150.10LV -			
	HF.Si.20.200.50 -			
	HF.Si.20.250.50A -			
	H ₂ O (Water) activated			
	Customized 1 -			
	Customized 2 -			
	Limits	External (ext)	Maximum 95 °C	
		Minimum 5°C		
	Temperature Sensor	Power Output	Heating 100 °C	
Calibration		Internal	2 Point Calibration 100 %	
Reset Calibration	Internal	3 Point Calibration -		
	External	2 Point Calibration -		
Notification	External	3 Point Calibration -		
	ON -			
Hysteresis ± 0.0 K				
Sound	Infinite -			
Beep activated				
PUMP	Limits	Speed	Maximum 4600 rpm	
		Minimum 1000 rpm		
Pressure	Maximum 0.7 bar			
	TIMER	Set 00:00 [hh:mm]		
Display	Display -			
MODE	A activated			
	B -			
	C -			
	D -			
DISPLAY	Main Screen	Pump activated		
	Device number 0			
Menu	Timer -			

GRAPH	Automatic	Manual	Axis Assignment	Set Temperature	activated
				Actual Internal Temp.	activated
	Axis Scaling		X - Axis	Actual External Temp.	activated
				15 min	-
	30 min		activated		
	60 min		-		
	120 min		-		
	Y - Axis		Maximum	95 °C	
			Minimum	5 °C	
	PROGRAMS		Program 1	-	
...		-			
Program 10		-			
MODULES	M1 - Valve	ON	ON	-	
			Default Status	Open	
		Control Method	Level	Closed	activated
				Start	Level 2
		Stop	Level 4		
		Pump OFF = Valve OFF	Temperature	Higher	95 °C
				Lower	5 °C
		Int/ext > Set Temperature	-		
		M2 - Output	Alarm	Error	-
				Warning	-
	Default Status			Open	
	Switch		ON	Closed	activated
				Default Status	Open
			Control Method	Level	Start
	Stop	Level 4			
	Pump OFF = Switch OFF	Temperature	Higher	95 °C	
			Lower	5 °C	
	Int/ext > Set Temperature	-			
	M3 - Input	Ext. Standby	ON	-	
			Default Status	Open	
OUTGAS	Speed	1000 rpm			
	Interval	10 s			
SAFETY	Time out	Set	Pump	OFF	
			Last set Value	activated	
		Tempering	Set	-	
			OFF	activated	
			Last Set Value	-	
			Last Actual Value	-	
	Set	-			
	Password	000			
	Safe Temp. Confirmation	-			
	SETTING	Languages	English	activated	
Deutsch			-		
Display		Background	Black	activated	
			White	-	
		Brightness	Standard Mode	50 %	
			Battery Mode	40 %	
Firmware Update Info		-			
Sound		Key Tone	-		
Factory Settings		-			
Communication		Device name	Circulator WiCo		
		Bluetooth	activated		
Information		Tempering	yes		
		Pump	yes		
		Safety	yes		
		Software	yes		
	Intro	yes			
Firmware Update Info	yes				

Menu (Details):



TEMPERING:

1. Control:

1) Control Mode:

Internal (int):

The temperature is regulated according to the internal temperature sensor (Fig. 2 Item 6).

Extern (ext):

The temperature is regulated according to the external temperature sensor (Fig. 2 Item 11).

2) Control parameters:

Automatic:

The optimal control parameters for PID temperature control are determined automatically. This is the recommended mode. Selecting "Automatic" allows you to set the dynamics for temperature control:

Accurate: precise tempering without overshooting.

Fast: fast tempering with minimal overshooting.

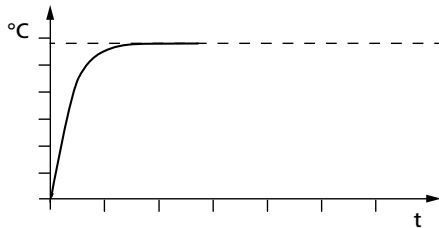

Fig. 26 (heating curve in "Automatic" mode)

Manual:

The control parameters for PID temperature control can be set manually.

"Manual" should only be used in the event of special temperature control requirements.

When "Manual" is selected, the following parameters can be set for "Internal (int)" and "External (ext)" temperature control:

Kp: Proportional coefficient

The proportional coefficient **Kp** is the controller amplification and determines how strongly the control deviation (the difference between the target temperature and actual temperature) directly affects the control variable (on-time of the heater). **Kp**-values that are too large can lead to the controller overshooting.

Ti: Integral time

The integral time **Ti** (s) is the correction time and determines how strongly the duration of the control deviation affects the control variable. **Ti** compensates for an existing control deviation. A high **Ti** means a smaller and slower effect on the control variable. **Ti**-values that are too small can lead to instability of the controller.

Td: Differential time

The differential time **Td** (s) is the derivative time and determines how strongly the rate of change of the control deviation affects the control variable. **Td** compensates for rapid control deviations. A high **Td** means a smaller and slower effect on the control variable. **Td**-values that are too large can lead to instability of the controller.

Ts: Sampling time

The sampling time **Ts** (s) is the time interval over which the control deviation is determined and the respective control variable (dependent on **Kp**, **Ti** and **Td**) is calculated.

Ts must be adjusted to match the response characteristic (total of all time constants) of the closed loop controlled system, so that the control variable can deliver a uniform and measurable change in the control deviation. **Ts** values that are too small or too large can lead to instability of the controller.

Prop_Bp: Proportional Band Maximum.

Prop_Bn: Proportional Band Minimum.

The Proportional Band is the range below (**Prop_Bp**) and above (**Prop_Bn**) the set value in which the control output value is calculated via the difference between the actual and the set value and the PID parameters.

Examples of non-optimal settings:

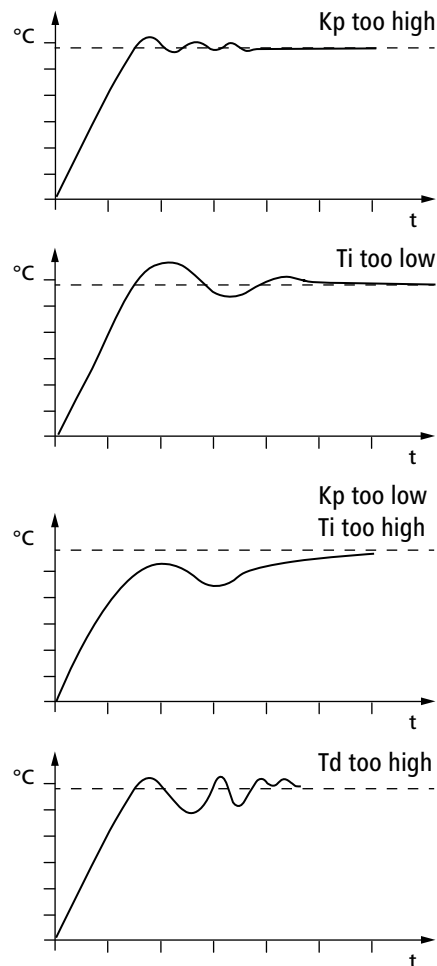

Fig. 27

3) Fluids:

Under the option "Fluids", a variety of heat transfer fluids can be selected.

The selected fluid limits the setting range of the target temperature. See table in the section "Fluids".

The maximum and minimum temperature values of the selected fluid can be set within these limitations.

2. Limits:

1) External (ext):

Under the option "External (ext)", the maximum and minimum temperature for external temperature control can be set.

2) I Δ T (int - ext) I:

Under "I Δ T (int - ext) I", the maximum difference between the internal and external temperature can be set.

3) Power Output:

Under "Power Output", the maximum heating output can be set as a percentage.

3. Temperature sensor:

1) Calibration:

The internal and the external temperature measurement can be calibrated and adjusted.

You can select 2-point calibration or 3-point calibration for internal and external measurement.

Calibration proceeding (example: 2-point calibration):

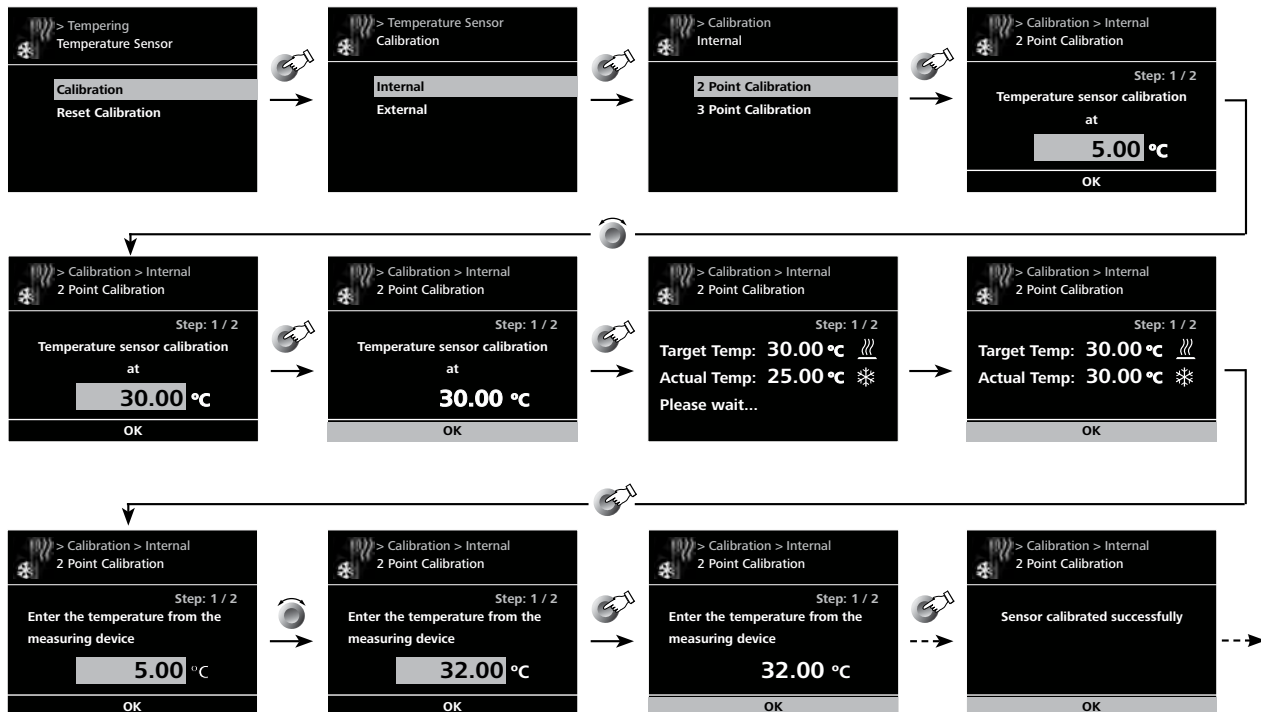

Fig. 28

2) Reset Calibration:

By "Reset Calibration", the calibration value for the internal or the external temperature sensor will be deleted.

4. Notification:

1) ON:

This menu option allows you to activate/deactivate the "Notification" function. A green check mark and a beep informing when the target value (hysteresis) has been reached.

2) Hysteresis:

This menu option allows you to set the hysteresis from 0 to ± 2.0 K.

3) Sound:

Infinite: Beep until you press the "Back" button.

Beep: Single beep.



PUMP

1. Limits:

In "Limits" option, the user is allowed to set the maximum and minimum speed to the pump, and also the maximum pressure.



TIMER

1. Set:

The user can set a target time (duration). When device functions are started normally, this time is displayed on the working screen. The device functions stop automatically once this time has expired. The running time is then displayed again on the display.

Note: To deactivate the target time specification, set the target time to 00:00.

2. Display:

Activate the timer display on the main display (working screen).



MODE

1. Operating Mode A:

After power-on/power failure no automatic restart of functions.

2. Operating Mode B:

After power-on/power failure automatic restart of functions, depending on previous settings.

3. Operating mode C:

Set values (set in A or B) cannot be changed. After power-on/power failure automatic restart of functions, depending on previous settings.

4. Operating mode D:

Confirmation request for set value changes if functions are active.



DISPLAY

1. Main Screen:

In the "Main screen" menu the user can specify what information will be displayed on the screen.

2. Device Number:

In the "Device number" menu option, you are allowed to edit the device number from 0 to 99 that will be shown on the main screen. When using multiple units, it may be helpful to identify **WiCo** and **station**.

Note: Labeling device number to the **station**.



GRAPH

In this menu, you can set the options for the time-temperature diagram.

1. Automatic:

The scaling of the temperature axis (Y-axis) is automatically determined, depending on the target temperature and the actual internal and external temperature. The time axis (X-axis) is permanently scaled to 30 minutes.

2. Manual:

1) Axis Assignment:

The temperature values to be displayed can be selected.

2) Axis scaling:

Scaling of the time (X) and temperature axis (Y) can be selected or set.



PROGRAMS

Under programs, 10 user-defined temperature-time profiles can be created. In addition, the pump speed and behaviour of the external switching outputs (MODULE M1 and M2) can be defined. A program can consist of up to 10 segments. Once a program has been selected, the following options are available:

1. Start:

Starts the program upon request of loop mode.

1) Infinite loop:

Upon completion of the last segment, the program continues with the first segment until the user ends the program by stopping a device function.

2) Loop Count:

Indicates the total number of loop cycles until program end.

When you start the program, the **WiCo** remind you to confirm the starting of the PR (Program) control. If you need to pause the PR control, press menu button.

Note: At the end of the program all device functions are switched off.

2. Edit:

Edit/change the program.

1) Seg No.:

Segment number.

2) Ctrl. Sensor (int/ext):

Determines whether control is through the internal (int) or external (ext) temperature sensor.

3) Temp.:

Target temperature.

4) Ctrl.Mode (Time / +/- x.x K):

In "Ctrl.Mode Time" the target values and settings of the segment are valid for the duration indicated in the column "Time hh:mm".

Afterwards, the next program segment is automatically executed.

In "Ctrl.Mode +/- x.xx K", the hysteresis (tolerance) of the actual temperature to the target temperature is set (e.g. +/- 0.1 K). The target values and settings of the segment are valid until the actual temperature reaches the target temperature +/- hysteresis for the first time.

Afterwards, the next program segment is automatically executed.

5) Pump rpm:

Target speed of pump.

6) M1 (ON / OFF):

MODULES M1-Valve:

OFF: M1 valve in initial state

ON: M1 valve in inverted initial state.

Note: The initial state of the M1 valve is defined in "MODULES M1-Valve" in "Default Status" as "Open" or "Closed".

7) M2 (ON/OFF):

MODULES M2-Output switch

OFF: M2-output switch in initial state.

ON: M2-output switch in inverted initial state.

Note: The initial state of the M2-Output switch is defined in "MODULES M2-Output-Switch" in "Default Status" as "Open" or "Closed".

Edit: Edit/change program parameters.

Delete: Delete selected yellow highlighted program segment.

Insert: Inserts a new program segment after the selected segment.

Save: Saves changes.

3. Delete:

Deletes the selected yellow highlighted program.

1) OK:

Confirm the process.

2) Cancel:

Cancels the process.

4. View:

Temperature-time overview displays for the program with segments of the selected program.

Note: If hysteresis is set as "Ctrl.Mode +/-x.xx K" for one or more segments in the program, the duration of the program cannot be determined.

Press and turn the knob (J) to display the segment details.

Once the program has been started, the program no., segment no. (active/total) and the remaining duration of the segment or hysteresis are displayed in the graph.



MODULES:

In "Modules" the multifunction connection (18) outputs and inputs can be configured.

The outputs M1 and M2 can be controlled via "PROGRAMS".

1. M1-Valve:

1) ON:

Switches the external valve to the active state (inverted initial state).

Note: When the "PROGRAMS" is started, the M1 segment settings have higher priority.

2) Default Status:

Defines the default state (OFF) of the external valve as "Open" or "Closed".

3) Control method:

Level: In this menu option, you can set and activate the start/stop fluid level for the valve.

When the menu option is activated, the valve opens when the filling level reaches the set start level and closes when the filling level reaches set stop level.

Pump OFF = Valve OFF: When the menu option is activated, the valve turns off when the pump is turned off.

Temperature: Temperature-dependent control of the M1-valve. By entering the boundaries of "Higher" and "Lower", the temperature range is set in which the M1-valve can be opened.

If you activate a rule "Int/ext> Set Temperature" is an automatic control of the M1-valve dependence on the target temperature.

By the "Hysteresis" value (set temperature hysteresis) the control stability can be optimized.

Note: Int/ext stands according to the selected control mode (internal (int) or external (ext)) for the actual temperature to be controlled.

2. M2-Output:

1) Alarm:

Activates the alarm output (switch contact).

Error: In the event of an error the "M2-Output — Switch" is activated (ON, inverted initial state).

Warning: In the event of a warning the "M2-Output — Switch" is activated (ON, inverted initial state)

When "Warning" is activated, "Error" is simultaneously activated.

Default Status: Defines the default state (OFF) of the "M2-Output — Alarm" as "Open" or "Closed".

2) Switch:

Activates the switch output.

ON:

Switches output into the active state (inverted initial state).

Note: When the "Program" is started, the M1 segment settings have higher priority.

Default Status:

Defines the initial state (OFF) of the switch output as "Open" or "Closed".

Control method:

Level: In this menu option, you can set and activate the start/stop fluid level for the switch.

When the menu option is activated, the switch starts to work when the filling level reaches the set start level and stops to work when the filling level reaches set stop level.

Pump OFF = Switch OFF: When the menu option is activated, the switch turns off when the pump is turned off.

Temperature: Temperature-dependent control of the M2-switch. By entering the boundaries of "Higher" and "Lower", the temperature range is set in which the M2-switch can be opened.

If you activate a rule "Int/ext> Set Temperature" is an automatic control of the M2-switch dependence on the target temperature.

By the "Hysteresis" value (set temperature hysteresis) the control stability can be optimized.

Note: Int/ext stands according to the selected control mode (internal (int) or external (ext)) for the actual temperature to be controlled.

3. M3-Input:

1) Ext. Standby:

External standby input to stop the device functions Temper and Pump.

ON: Activates the ext. standby function. Device functions are stopped in the event of an inverted initial state (ON) at the input.

Default Status: Defines the default state (OFF) of the input as "Open" (high level) or "Closed" (low level).



OUTGAS

In the option, the user is allowed to set the outgas speed in range of 1000 rpm to 4600 rpm and outgas interval from 10 seconds to 240 seconds.

This function can be used when filling external devices such as laboratory reactors.



SAFETY

1. Time out:

1) Set:

In the menu "Set", the user can determine a time limit in the event of a communication breakdown between the station and the **Wireless Controller**. The station continues to work with the preset target values until the preset time value has expired. Following that, the station runs using the preset safety temperature and safety speed.

Note: The initial time out is 1 minute and the user can define up to 60 minutes for this time limit.

2) Pump:

OFF: When this menu option is activated, the pump function switches off in the event of a communication breakdown between the **station** and the **WiCo**.

Last Set Value: When this menu option is activated, the pump continue to run with last set speed value in the event of a communication breakdown between the **station** and the **WiCo**.

Set: When this menu option is set and activated, the pump continue to run with the set speed value in the event of a communication breakdown between the **station** and the **WiCo**.

3) Tempering:

OFF: When this menu option is activated, the tempering function switches off in the event of a communication breakdown between the **station** and the **WiCo**.

Last Set Value: When this menu option is activated, the tempering function continue to work with last set temperature value in the event of a communication breakdown between the **station** and the **WiCo**.

Last Actual Value: When this menu option is activated, the tempering function continue to work with last actual temperature value in the event of a communication breakdown between the **station** and the **WiCo**.

Set: When this menu option is set and activated, the tempering function continue to work with the set temperature value in the event of a communication breakdown between the **station** and the **WiCo**.

2. Password:

In the "Password" menu, the menu settings can be locked by a 3-digit password.

3. Safe Temp. Confirmation:

This menu allow you to confirm the safe temperature of the **station** at start-up. A check mark (✓) indicates that the function is activated.



SETTING

1. Languages:

The "Language" option allows the user to select the desired language.

2. Display:

The "Display" option allows the user to change the background color and brightness of the working screen.

3. Sound:

The "Sound" option allows the user to activate/deactivate the key tone.

4. Factory Settings:

Select the "Factory settings" option by turning and pressing the rotary/push knob. The system requests confirmation to restore the factory settings. Pressing the "OK" button resets all the system settings to the original standard values set at dispatch from the factory (see "Menu structure").

5. Communication

1) Device Name:

The "Device Name" menu option allows you to edit the device name. This can relatively identify the paired **station**.

2) Bluetooth:

The "Bluetooth®" option allows the user to activate/deactivate the "Bluetooth®" function. A tick shows that the option is activated.

6. Information:

The "Information" option offers the user an overview of the most important system settings of the device.

Interface and output

The device can be connected to a PC and operated with the laboratory software *labworldsoft®* through the RS 232 port (9), USB port (10) or USB port on the **Wireless Controller (WiCo)**.

Note: Please comply with the system requirements together with the operating instructions and help section included with the software.

USB interface:

The Universal Serial Bus (USB) is a serial bus for connecting the device to the PC. Equipped with USB devices can be connected to a PC during operation (hot plugging). Connected devices and their properties are automatically recognized. The USB interface can also be used to update firmware.

USB device drivers:

Connect the IKA device through the USB data cable to the PC. The data communication is via a virtual COM port. Configuration, command syntax and commands of the virtual COM ports are as described in RS 232 interface.

From Windows 10 and onwards the standard Windows USB driver is automatically loaded and a COM port number is assigned (find details in Windows Device Manager: "USB Serial Port (COMxx)"). If you have problems with USB communication, first ask your IT system administrator whether access to the USB interface is restricted for data security reasons.

RS 232 interface:

Configuration

- The functions of the interface connections between the stirrer machine and the automation system are chosen from the signals specified in EIA standard RS 232 in accordance with DIN 66 020 Part 1.

- For the electrical characteristics of the interface and the allocation of signal status, standard RS 232 applies in accordance with DIN 66 259 Part 1.
- Transmission procedure: asynchronous character transmission in start-stop mode.
- Type of transmission: full duplex.
- Character format: character representation in accordance with data format in DIN 66 022 for start-stop mode. 1 start bit; 7 character bits; 1 parity bit (even); 1 stop bit.
- Transmission speed: 9600 bit/s.
- Data flow control: none
- Access procedure: data transfer from the stirrer machine to the computer takes place only at the computer's request.

Command syntax and format:

The following applies to the command set:

- Commands are generally sent from the computer (Master) to the device (Slave).
- The device sends only at the computer's request. Even fault indications cannot be sent spontaneously from the device to the computer (automation system).
- Commands are transmitted in capital letters.
- Commands and parameters including successive parameters are separated by at least one space (Code: hex 0x20).
- Each individual command (incl. parameters and data) and each response are terminated with CR LF (Code: hex 0x0d hex 0x0A) and have a maximum length of 80 characters.
- The decimal separator in a number is a dot (Code: hex 0x2E).

The above details correspond as far as possible to the recommendations of the NAMUR working party (NAMUR recommendations for the design of electrical plug connections for analogue and digital signal transmission on individual items of laboratory control equipment, rev. 1.1).

The NAMUR commands and the additional specific **IKA** commands serve only as low level commands for communication between the device and the PC. With a suitable terminal or communications programme these commands can be transmitted directly to the circulator equipment. The **IKA** software package, Labworldsoft®, provides a convenient tool for controlling circulating equipment and collecting data under MS Windows, and includes graphical entry features, for pump motor speed ramps for example.

Commands:

Commands	Function
IN_PV_1	Read the external actual temperature
IN_PV_2	Read the internal actual temperature
IN_PV_3	Read the safety actual temperature
IN_PV_4	Read the pump actual speed
IN_SP_1	Read the internal setting temperature (if 0: internal control) Read the external setting temperature (if 1: external control)
IN_SP_3	Read the safety setting temperature
IN_SP_4	Read the pump setting speed
IN_TMODE	Read temperature control 0: internal control 1: external control
OUT_SP_1 xxx	Set the internal setting temperature XXX (if 0: internal control) Set the external setting temperature XXX (if 1: external control)
OUT_SP_12@n	Set the WD safety temperature to n (e.g. 40 °C). Echo of the safety temperature.
OUT_SP_4 xxx	Set the pump speed XXX
OUT_SP_42@n	Set the WD-safety speed to n (e.g. 2000 rpm). Echo of the safety speed.
OUT_TMODE_0	Set to Internal temperature control
OUT_TMODE_1	Set to External temperature control
OUT_WD1@n	Start the watchdog mode 1 and set the time for the watchdog to n (20...1500) seconds. Echo of the Watchdog time. During a WD1-event, the heating and pump functions are switched off. This command needs to be send within the watchdog time.
OUT_WD2@n	Start the watchdog mode 2 and set the watchdog time to n (20...1500) seconds. Echo of the watchdog time. During a WD2-event, the set temperature is changed to the WD safety temperature and the pump set speed is set to the WD safety speed. This command needs to be send within the watchdog time.
RESET	Reset the PC control and stop the device functions.
START_1	Start the heating function
START_4	Start the pump function
STOP_1	Stop the heating function
STOP_4	Stop the pump function

PC 1.1 Cable:

This cable is required to connect RS 232 port (9) to a PC.

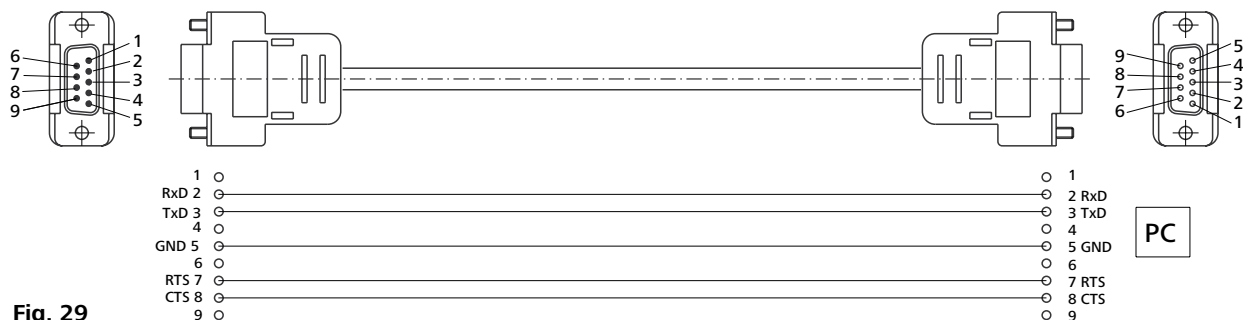
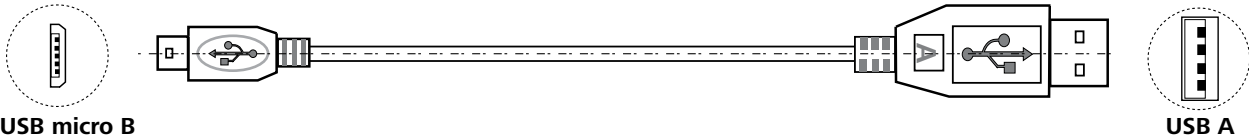

Fig. 29

USB 2.0 Kabel A - Micro B:

This cable is required to connect USB interface (10) to a PC.



USB micro B
Fig. 30

USB 2.0 Kabel Micro A - Micro B:

This cable is required to connect the **WiCo** to **station**.

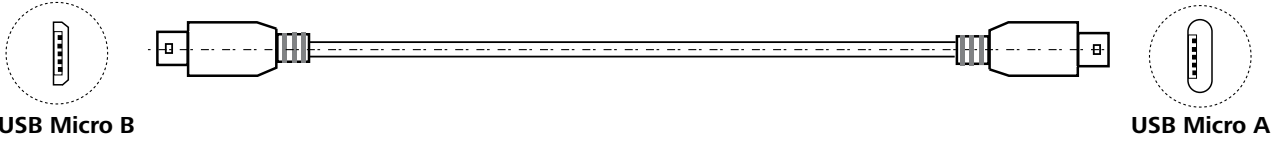

USB Micro B
Fig. 31

Connection WiCo to Station:

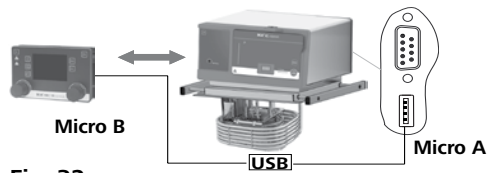

Fig. 32



Connection the device to PC:

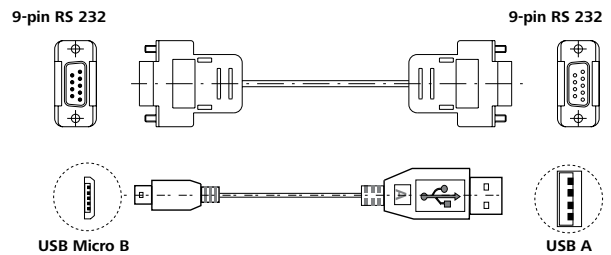
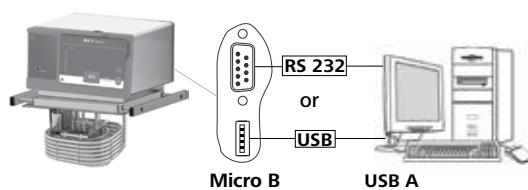
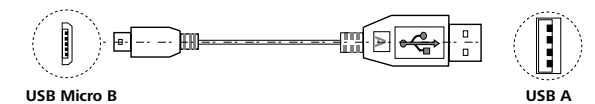
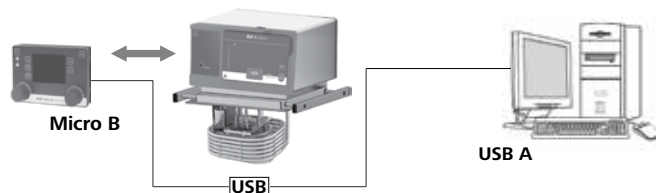
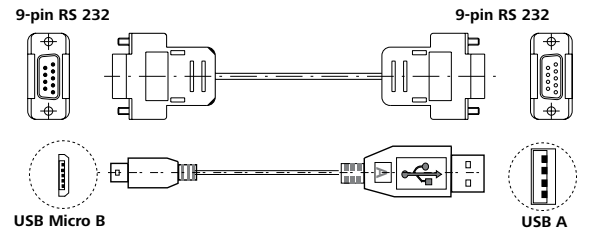
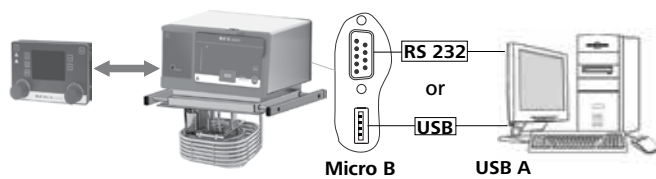
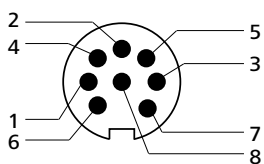

Fig. 33

Multifunction interface:



- 1 M1 Output Valve + (+24Vdc/max. 0.8A)
- 2 M1 Output Valve -
- 3 M2 Output Alarm/Switch 1 (max. 30Vdc/ac/max. 1A)
- 4 M2 Output Alarm/Switch 2
- 5 M3 Input standby + (+5V ca. 10mA)
- 6 M3 Input standby - (0V only for Standby)
- 7 --- (reserved for later use, do not connect!)
- 8 --- (reserved for later use, do not connect!)

Fig. 34

Maintenance and cleaning

The device is maintenance-free. It is only subject to the natural wear and tear of components and their statistical failure rate.

Cleaning:

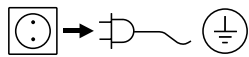

For cleaning disconnect the mains plug!

Use only cleaning agents which have been approved by IKA to clean IKA devices: Water containing tenside/ isopropyl alcohol.

- Wear protective gloves while cleaning the device.
- Electrical devices may not be placed in the cleansing agent for the purpose of cleaning.
- Do not allow moisture to get into the device when cleaning.
- Before using another than the recommended method for cleaning or decontamination, the user must ascertain with IKA that this method does not damage the device.

Spare parts order:

When ordering spare parts, please give:

- Machine type
- Serial number, see type plate
- Item and designation of the spare part, spare parts diagram and list.
- Software version.

Repair:

Please send the device for repair only after it has been cleaned and is free from any materials which may constitute a health hazard.

For repair, please request the "Decontamination Certificate" from IKA, or download printout of it from the IKA website.

If you require servicing, return the device in its original packaging. Storage packaging is not sufficient. Please also use suitable transport packaging.

Error codes

Any malfunctions during operation will be identified by an error message on the display.

Proceed as follows in such cases:

- Switch off device using the main switch at the back of the device
- Carry out corrective measures
- Restart device

Error code	Effect	Cause	Solution
Error 01	Pump off Heating off	No external temperature sensor	- Check this sensor
Error 02	Pump off Heating off	Motor over current (rate current)	- Reduce pump motor speed - Use fluid with lower viscosity - Check if the pump impeller is blocked
Error 03	Pump off Heating off	Motor over current (max current)	- Reduce pump motor speed - Use fluid with lower viscosity - Check if the pump impeller is blocked
Error 04	Pump off Heating off	Motor hall signal missing	- Reduce pump motor speed - Use fluid with lower viscosity - Check if the pump impeller is blocked
Error 05	Pump off Heating off	Too high liquid level	- Check the liquid level and buoyage
Error 06	Pump off Heating off	Too low liquid level	- Check the liquid level and buoyage
Error 07	Pump off Heating off	Too high voltage	- Check the mains power
Error 08	Pump off Heating off	Too low voltage	- Check the mains power
Error 09	Pump off Heating off	Device internal temperature is too high	- Check the ambient temperature and let the device cool down
Error 10	Pump off Heating off	PC communication failure	- Check communication cable

Error 11	Pump off Heating off	Temperature difference between control sensor and safety sensor is too much	- Check safety temperature circuit and bath fluid
Error 12	Pump off Heating off	Safety temperature alarm	- Check the bath temperature measurement
Error 13	Pump off Heating off	Heater switched off by safety circuit	- Check safety temperature set value, liquid level
Error 14	Pump off Heating off	Fan error	- Check the fan and clean the grids at the rear side

If the actions described fails to resolve the fault or another error code is displayed then take one of the following steps:

- Contact the service department
- Send the device for repair, including a short description of the fault.

Accessories

	IC control	HBC 5 control	HBC 10 control
Tubing and hoses			
LT 5.20 metal hose (isolated M16 x 1)	•	•	•
LT 5.21 PTFE hose (isolated M16 x 1)	•	•	•
H.PVC.8 PVC hose (nominal width 8)	•	•	•
H.PVC.12 PVC hose (nominal width 12)	•	•	•
H.SI.8 silicone hose (nominal width 8)	•	•	•
H.SI.12 silicone hose (nominal width 12)	•	•	•
Tubing Insulations			
ISO. 8 insulation (8 mm)	•	•	•
ISO.12 insulation (12 mm)	•	•	•
Bath vessels			
IB eco 8 Plastic bath (8 litre)	•		
IB eco 18 Plastic bath (18 litre)	•		
IB pro 9 Stainless steel bath (9 litre)	•		
IB pro 12 stainless steel bath (12 litre)	•		
IB pro 20 stainless steel bath (20 litre)	•		
Bridges and Covers			
BS.IC small bridge (for IB pro 12 , IB eco 18 and IB pro 20)	•		
CM.IC medium cover (for IB pro 12)	•		
CL.IC large cover (for IB pro 20)	•		
Additional accessories			
Pt 100.30 temperature sensor	•	•	•
PC 1.1 cable (RS 232)	•	•	•
USB cable micro A – micro B 2.0	•	•	•
USB 2.0 cable A – micro B	•	•	•
OS 1.0 Power supply	•	•	•
RB 1 Battery pack	•	•	•
Labworldsoft®	•	•	•

See more accessories on www.imlab.eu.

Technical data

		IC control	HBC 5 control	HBC 10 control
Operating voltage	VAC	230 ± 10 % / 100 ... 115 ± 10 %		
Frequency	Hz	50 / 60		
Max. input Power	W	2650 (230 VAC) / 1400 (115 VAC)		
Working temperature range (RT+10 at 1000 rpm)	°C	RT + 10 ... 250		
Operating temperature range (with external cooling)	°C	-20 ... 250		
Temperature stability – Internal temperature control 70°C, water (according to DIN12876)	K	± 0.01		
Temperature control		PID (Automatic/user setting)		
Temperature measurement, absolutely accuracy Internal (int) (adjustable by calibration)	K	± 0.2		
External (ext) (adjustable by calibration)	K	± 0.2		
External Pt 100.3 temperature sensor tolerance to DIN EN 60751 class A, ≤ ± (0.15 + 0.002 x T), e.g. at max. 100°C (adjustable by calibration)	K	± 0.35 (at 100°C)		
Temperature setting		Knob on Wireless Controller (WiCo)		
Temperature setting resolution	K	0.1		
Temperature display		TFT LCD on WiCo		
Temperature display resolution	K	0.01		
Classification according to DIN 12876-1		Class III (FL) suitable for flammable and non-flammable fluids		
Safety circuit (adjustable)	°C	0 ... 260		
Safety temperature display		TFT LCD on WiCo		
Heating capacity	W	2500 (230 VAC) / 1250 (115 VAC)		
Pump speed (adjustable)	rpm	1000 ... 4600		
Max. pump pressure/suction	bar	0.61 / 0.45		
Max. flow rate (at 0 bar)	l/min	31		
Bath volume	l	-/-	5 ... 7	8 ... 11
Sub-level protection		Yes		
Interface		RS 232, USB, Multi-function interface		
Permitted on-time	%	100		
Protection class according to EN 60529		IP 21		
Protection class		I		
Excess voltage category		II		
Contamination level		2		
Permitted ambient temperature	°C	+5 ... +40		
Permitted ambient humidity (relative)	%	80		
Dimension (W x D x H)	mm	285 x 291 x 313	275 x 500 x 406	275 x 510 x 456
Weight	kg	8.8	17.3	18.3
Operation at a terrestrial altitude	m	max. 2000		
Wireless Controller				
Permitted on time	%	100		
Max. communication distance (dependent on the building)	m	15		
Dimensions (W x D x H)	mm	160 x 40 x 105		
Weight	kg	0.3		
Ambient temperature	°C	+5 ... +40		
Ambient humidity (relative)	%	80		
Protection class according to EN 60529		IP 40		
Interface		USB		
RB 1 Battery pack				
Voltage	V	3.7		
Charging capacity	mAh	2000		
Charging time	h	4,5		
Working time	h	15		
Battery type		Lithium-polymer		

Subject to technical changes!

Warranty

In accordance with IKA warranty conditions, the warranty period is 24 months. For claims under the warranty please contact your local dealer. You may also send the machine direct to our factory, enclosing the delivery invoice and giving reasons for the claim. You will be liable for freight costs.

The warranty does not cover worn out parts, nor does it apply to faults resulting from improper use, insufficient care or maintenance not carried out in accordance with the instructions in this operating manual.

Pump performance curve

Pump performance curve measured with water:

(Measurements done according DIN 12876-2 with water at 20°C; pump in a closed-loop circuit).

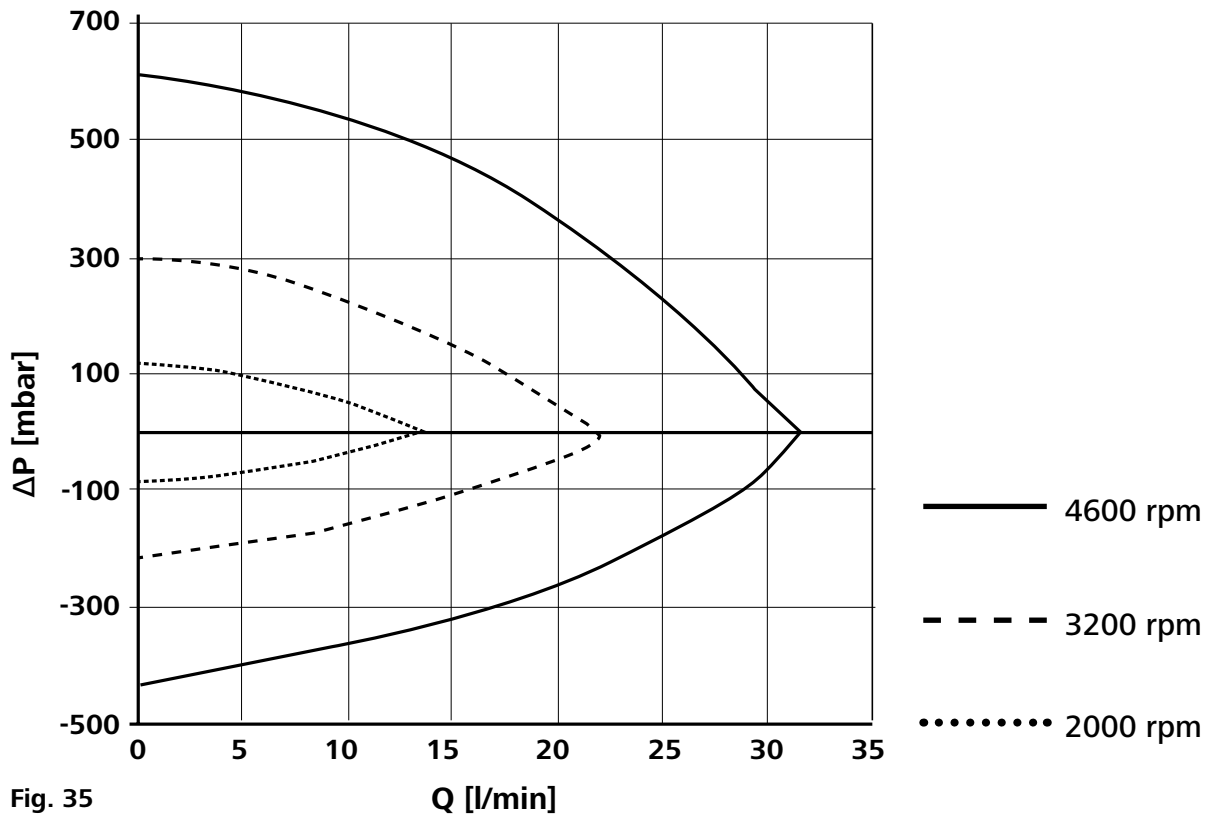

Fig. 35