

IKA

designed for scientists

INC 125 FCS digital

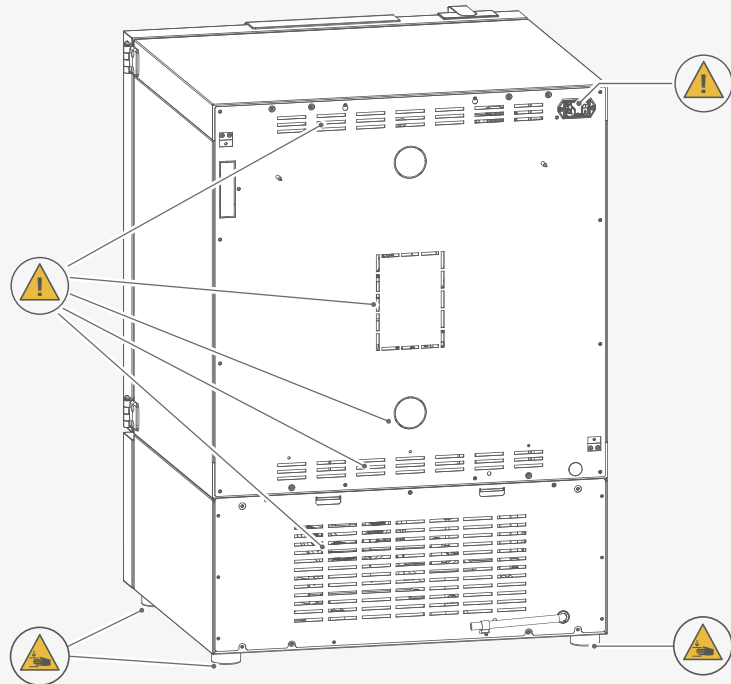
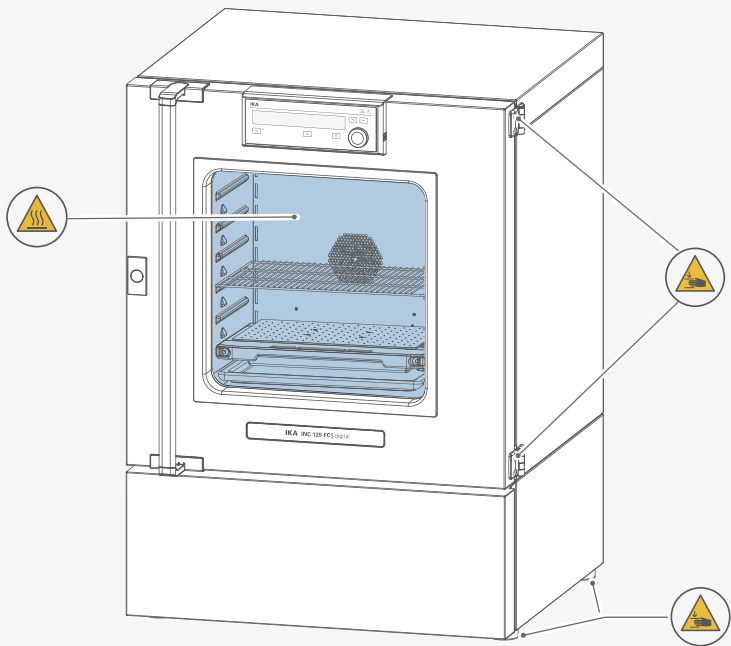

Fig. 1

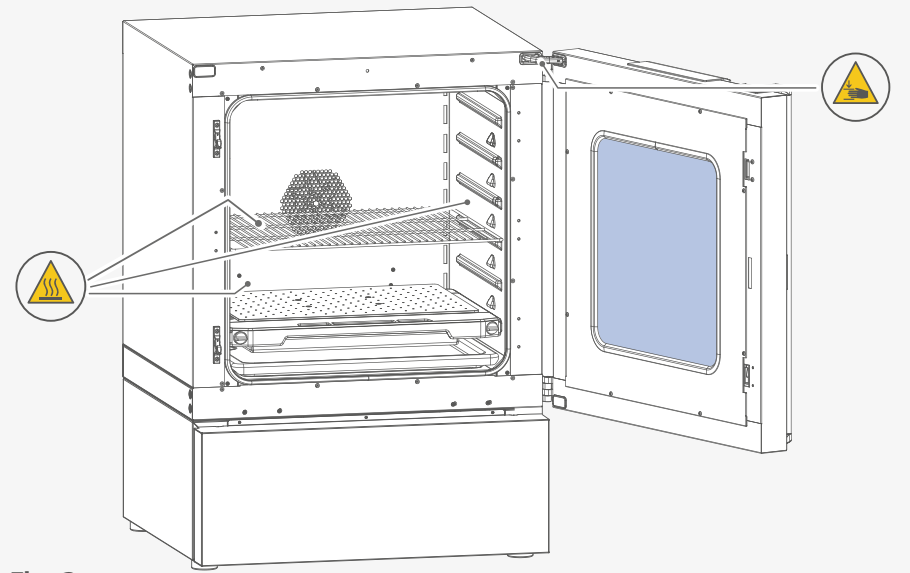











Fig. 2

	EU Declaration of conformity	7
	Explication of warning symbols	7
	Safety instructions.....	8
	Intended use.....	12
	Useful information	13
	Unpacking	15
	Installation.....	16
	Operator panel and display	30
	Operation	32
	Setting menu navigation and structure.....	47
	Interfaces and outputs	55
	Error codes	58
	Maintenance and cleaning	60
	Shaking platform	64
	Accessories	65
	Technical Data	66
	Warranty	67
	Dimensions	67

EU Declaration of Conformity







We declare under our sole responsibility that this product corresponds to the directives 2006/42/EG, 2014/35/EU, 2014/30/EU and 2011/65/EU and conforms with the following standards or normative documents: EN 61010-1, EN 61010-2-010, EN 61010-2-051, EN 61326-1, EN 60529, EN ISO 12100 and DIN 12880.

A copy of the complete EU Declaration of Conformity or further declarations of conformity can be requested.



Explication of warning symbols

/// Warning symbols

-  **Danger!** Indicates an (extremely) hazardous situation, which, if not avoided, will result in death, serious injury.
-  **Warning!** Indicates a hazardous situation, which, if not avoided, can result in death, serious injury.
-  **Caution!** Indicates a potentially hazardous situation, which, if not avoided, can result in injury.
-  **Notice!** Indicates practices which, if not avoided, can result in equipment damage.
-  **Warning!** Indicates the risk of fire or explosion.
-  **Warning!** Indicates a risk of biohazard infection.
-  **Caution!** Indicates a hazardous situation that cause by a hot surface.
-  **Caution!** Indicates crushing risk to fingers/hands.



/// General Symbols

A — Position number



Correct / Result!

Shows the correct execution or the result of an action step.



Wrong!

Shows the incorrect execution of an action step.



Note!

Displays action steps that require particular attention to detail.



Closed lock

Indicates the status of "locked".



Open lock

Indicates the status of "Unlocked".



Safety instructions

/// General information

- › **Read the operating instructions completely before starting up and follow the safety instructions.**
- › Keep the operating instructions in a place where it can be accessed by everyone.
- › Ensure that only trained staff work with the device.
- › Follow the safety instructions, guidelines, occupational health and safety and accident prevention regulations.
- › The device must only be used in a technically perfect condition.

Notice!

- › Pay attention to the marked sites in Fig. 1 and Fig. 2.

/// Transportation / Device setup

Danger!

- › Beware of the high dead weight of the device when transporting.

Caution!

- › Ensure that your fingers do not get crushed when setting down the device.

Caution!

- › The power switch of the device must be accessed immediately, directly and without risk at any time. If access to the power switch cannot be ensured, an additional emergency stop switch that can be easily accessed must be installed in the work area.

Notice!

- › Set up the device in a spacious area on an even, stable, clean, non-slip, dry and fireproof surface.
- › The feet of the equipment must be clean and undamaged.
- › Please note that the **INC 125 FCS digital** can only be stacked in the lower position. The **INC 125 F digital** and **INC 125 FS digital** devices can be stacked in the upper position.
- › Make sure that the ventilation slots are not blocked at back of the device.
- › Observe the minimum distances: between devices and wall min. 150 mm.

/// Working with the device

Danger!

- › Do not use the device in explosive atmospheres, it is not EX-protected.
- › To avoid body injury and property damage, observe the relevant safety and accident prevention measures when processing hazardous materials.

Warning!

- › Processing of materials:
 - Only process samples that will not react dangerously to the extra energy produced through processing. This also applies to any extra energy produced in other ways, e.g. through light irradiation.
 - Process pathogenic material only in closed vessels under a suitable fume hood. Please contact IKA application support if you have any question.
- › Additional safety measures:
 - Regardless of this, we recommend that users who work with critical or hazardous materials to take additional appropriate measures to ensure safety in the experiment. This can be done, for example, using higher-level monitoring equipment.
- › Hazards associated with the device:
 - The device heats, cools and circulates the air according to the specified parameters.
 - There is a danger of high temperatures, fire and general hazards in the handling of electrical energy.
 - Operator safety cannot be guaranteed simply by special design requirements of the device.
 - Further hazard sources may arise due to the type of tempering sample, e.g. if certain temperature thresholds are exceeded.
 - It is not possible to foresee all possible hazards. Therefore, it is largely subject to the judgment and responsibility of the operator to take additional safety precautions.
- › How to use the device:
 - The device may only be used as intended and in accordance with these operating instructions.
 - This also applies to operation by trained specialists.
- › Door opened during operation:
 - May cause the device to overheat and pose a fire hazard. Do not leave the door open during operation.
- › Do not operate the device if:
 - it is damaged
 - cable is damaged.

Warning!

- › Risks may also be posed by biological or microbiological substances.
- › Observe the national regulations for handling these substances, the biological security level of your laboratory, the material safety data sheets and the manufacture's application notes.
- › For complete instructions on handling of germs or biological material in risk group II or higher, please refer to the "Laboratory Biosafety Manual" (source: World Health Organization).

Caution!

- › There is a crushing risk when opening or closing the door. Keep your hands away from squeezing edges.

Caution!

- › The inner chamber, the glass window on the door and the door gasket may become hot during operation. Do not touch these parts during operation.
- › Risk of burns caused by vapour or hot surface. Pay attention to the residual heat after switching off the device.

Caution!

- › Media may only be processed or heated with this device in safe operation without monitoring if their flash point lies above the set safety temperature limit. The set safety temperature limit must be at least 25°C below the flash point of the medium in use (EN 61010-2-010).
- › The device must have cooled down before loading/unloading.
- › Heavy loads can lead to tilting of the device. Observe loading recommendations for the shelves.
- › Do not move any loaded shelves.

Notice!

- › Covers or parts that can be removed from the device without tools must later be refitted to ensure safe operation. This will prevent the infiltration of foreign objects, liquids and other contaminants.
- › Never use the device for:
 - heating food
 - drying living beings
 - heating room
- › Pay attention to the vessels on the shaking platform when setting the shaking speed. This prevents the medium to be shaken from splashing out of the sample vessels.
- › If the shaking vessels break during operation or the media is spilt, interrupt the shaking process immediately, remove any vessel residue and clean the device.
- › All accessories and vessels in place for the shaking process must be firmly secured.
- › Shaking vessels which are not properly secured could get damaged or be projected out. It is essential to regularly check that the vessels to be shaken and the attachments are firmly secured, especially before using the device again.
- › Avoid allowing objects to push or strike the shaking platform.

/// Accessories

Caution!

- › Use the locking brake when using the roller frame or roller box.
- › Protect the device and accessories from bumping and impacting.
- › Check the device and accessories beforehand for damage each time when you use them. Do not use damaged components.
- › Safe operation is only guaranteed with the accessories described in the "Accessories" section.
- › Only use IKA approved accessories.
- › Use only original IKA spare parts.

/// Power supply / switching off the device

- › The voltage stated on the type plate must correspond to the power voltage.
- › The device can only be disconnected from the power supply by pulling out the power plug or the connector plug.
- › The device must only be operated with the original power cord set.
- › The socket for the power cord must be easily accessible.
- › Socket must be earthed (protective ground contact).
- › After a power failure during operation, the device may start automatically (depending on operating mode).
- › Disconnect the power plug before cleaning, maintenance and transportation of the device.

/// Maintenance

- › The device must only be opened by trained specialists, even during repair. The device must be unplugged from the power supply before opening. Live parts inside the device may still be live for some time after unplugging from the power supply.

/// Disposal instructions

- › The device, accessories and packaging must be disposed of in accordance with local and national regulations.

/// Handling the refrigerant used

Warning!

- › Cooling unit and refrigerant:
 - The cooling unit of this device contains the refrigerant propane R 290.
 - This environmentally friendly natural gas is flammable.
 - Insufficient ventilation can lead to the formation of explosive mixtures. Therefore, only use the device in well-ventilated areas and keep all ventilation openings open.
 - Avoid open flames and sources of ignition and ensure good ventilation.
 - The refrigerant could escape if the cooling circuit is damaged.
 - Only the manufacturer is allowed to open and repair the closed refrigeration system.
- › Minimum room size:
 - The minimum room size is 7.0 m³ so that in the event of a fault (leakage of the complete refrigerant charge), no ignitable refrigerant-air mixture can be produced (R 290 max. 8 g/m³ room air).



Intended use

/// Use

The device is suitable for tempering (heating/cooling) and shaking of non-explosive, non-flammable or harmless substance and objects. It is also suitable for drying e.g. glassware or warm storing of liquids in container.

Due to the highly precise temperature control, the device is especially suitable for incubation of cultures at a standard temperature of 37 °C.

Warning!

The device must only be used for heating up non-explosive and non-flammable substances and objects. Do not process substances or objects that might cause explosive vapour.

The device is not classified as a medical device as defined by Medical Device Directive.

/// Range of use

Indoor environments similar to that a laboratory of research, teaching, trade or industry.

The safety of the user cannot be guaranteed:

- › if the device is operated with accessories that are not supplied or recommended by the manufacturer.
- › if the device is operated improperly or contrary to the manufacture's specifications.
- › if the device or the printed circuit board are modified by third parties.

Useful information

/// Material

The inner chamber of the device is made of high quality stainless steel AISI 304. The window on the door is made of tempered glass.

Notice!

Do not temper substances containing acids and halogenoids with this device!

/// Air flow

In recirculation mode, the fan ensures that the temperature in the incubator is distributed gently and evenly.

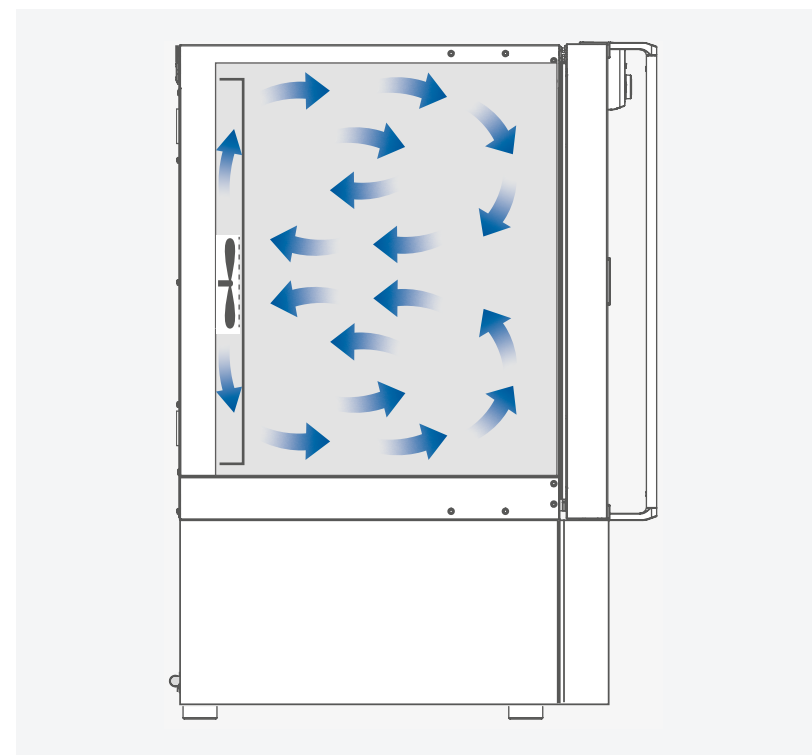

Warning!

Any component of the tempering material must not be able to release toxic gases.

/// Condensation

Condensation may appear depending on ambient condition. Regularly wipe the inner chamber dry.

/// Temperature monitoring

The device has a temperature limiter (TB) class 1 according DIN 12880. This means that in case of a single failure the device is switched off at 150 °C. The temperature may be higher for a short time in the area of the heater and on the walls. So beware of risk of fire or explosion of unsuitable load.

/// Calibration and adjustment

This menu shows how the values can be entered after the respective temperatures are approached and with an external measuring device cross-checked (calibrated).

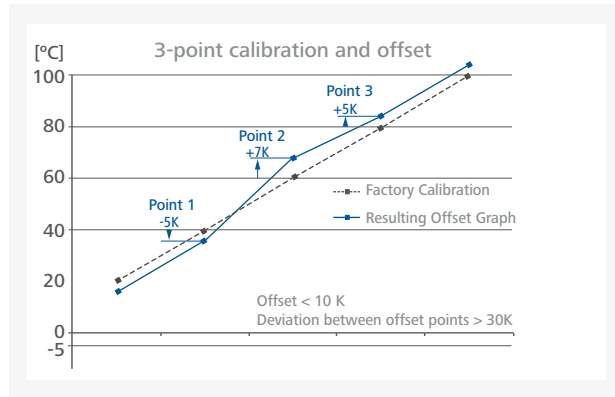

Individual load and ambient condition might influence the temperature behaviour of the chamber. To compensate that influence there's the option to neutralize by using the 3-point calibration and offset function. This function allows the temperature to be calibrated and adjusted at three different temperature values.

Use a calibrated reference measuring device in case of adjustment.

The operation can be done at a single, or up to three temperature levels:

Point 1: Temperature calibration and adjustment at low value of temperature.

Point 2: Temperature calibration and adjustment at medium value of temperature.

Point 3: Temperature calibration and adjustment at high value of temperature.

Unpacking



- > Please unpack the device carefully.
- > Any damage should be notified immediately to the shipping agent (post office, railway network or logistics company).

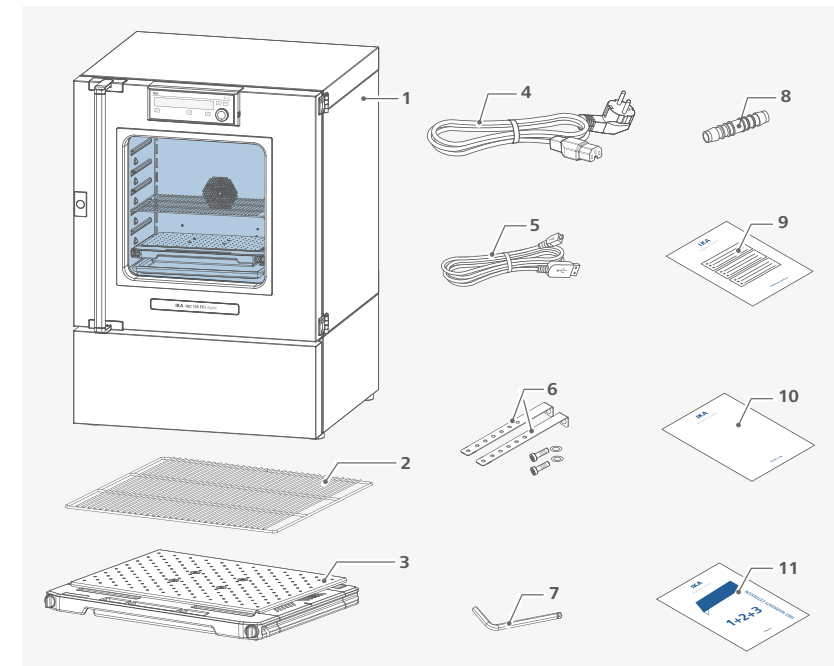

1	INC 125 FCS digital	7	Hexagon socket offset screw key
2	Shelf	8	Hose adapter
3	SP 20 shaking platform	9	Calibration certification
4	Power cord set	10	User guide
5	USB cable	11	Warranty card
6	Tilt protections		

Note: The design of the device and accessories may be changed without prior notice for the purpose of improvement.



Installation

/// Transportation / setting down the device

⚠ Warning!

- › Beware of the high dead weight of the device when transporting.
- › The device should only be transported by qualified persons with suitable handling equipment, such as a pallet truck and forklift!

The device can be transported:

- With a forklift truck

- With a pallet truck.

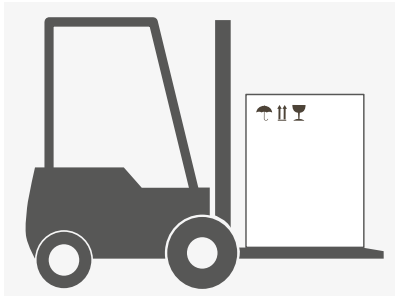

⚠ Caution!

- › Ensure that your fingers do not get crushed when setting down the device.
- › For lifting the device, four people are required.
- › You may get your hands or feet squashed when transporting and setting down the device. Wear protective gloves and safety boots.

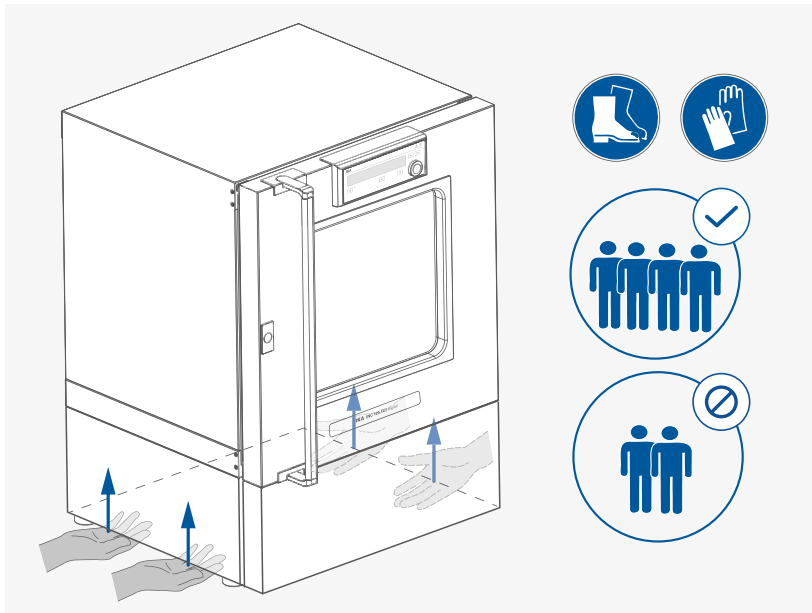

⚠ Notice!

When lifting the device, do not use the door / door handle. This may damage the device.

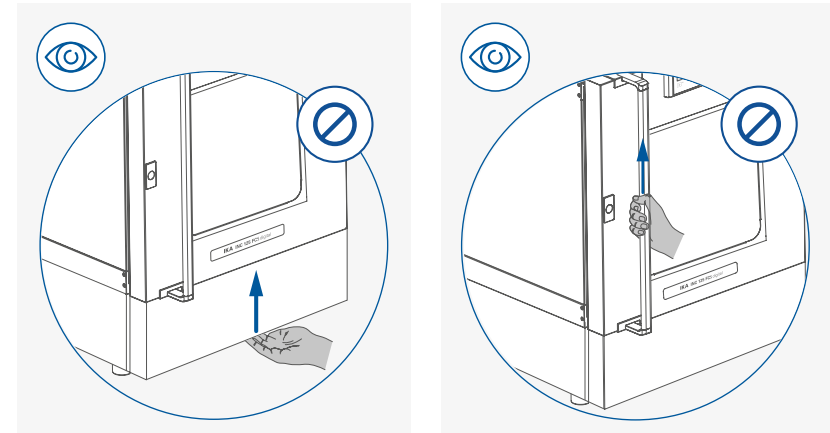

/// Setting up / Fixing the device to the wall

- › Place the device on an even, clean, dry and fireproof surface in well-ventilated environment.
- › Keep sufficient distance to radiators and other heat sources.
- › Keep at least 150 mm between walls and the device.

⚠ Caution!

Fixation against the wall is compulsory!

As indicated in following figures, attach the device to a wall with the tilt protections included with the device. Fasten the tilt protections to the rear side of the device with included hexagon socket screws and screw key.

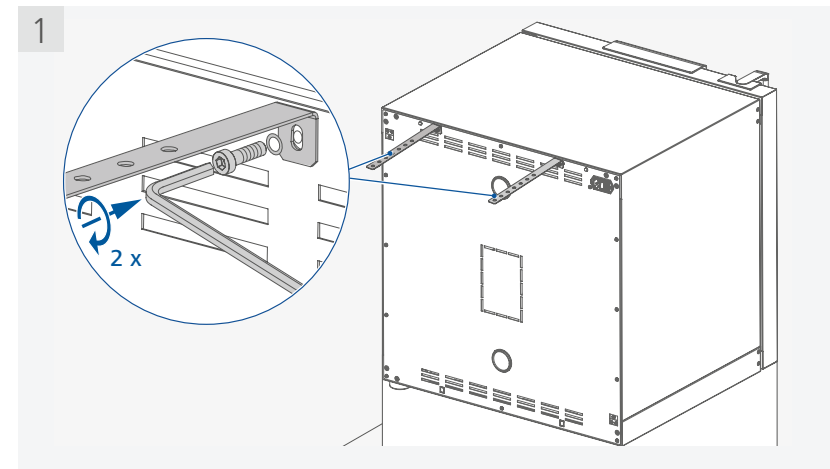

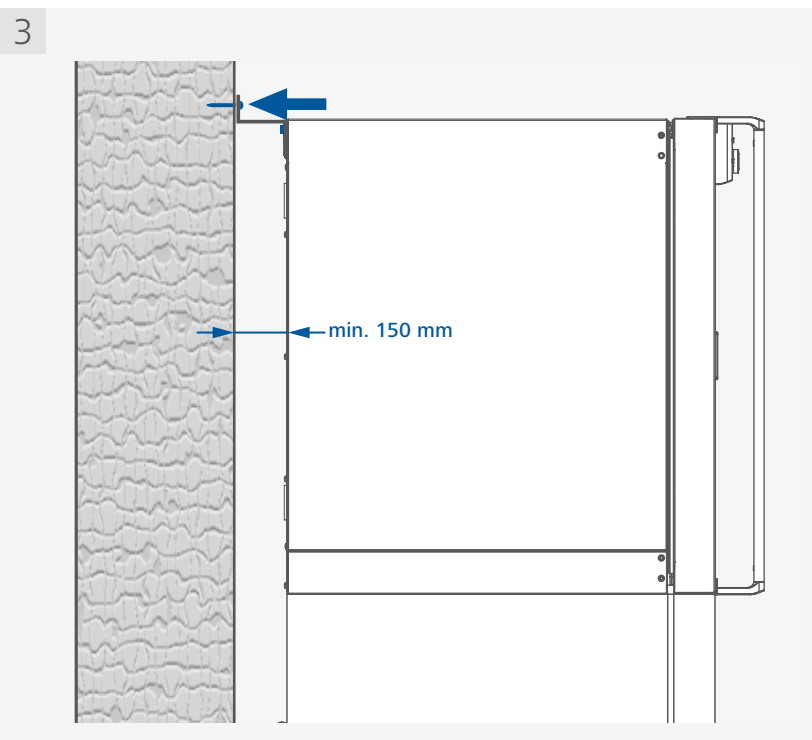
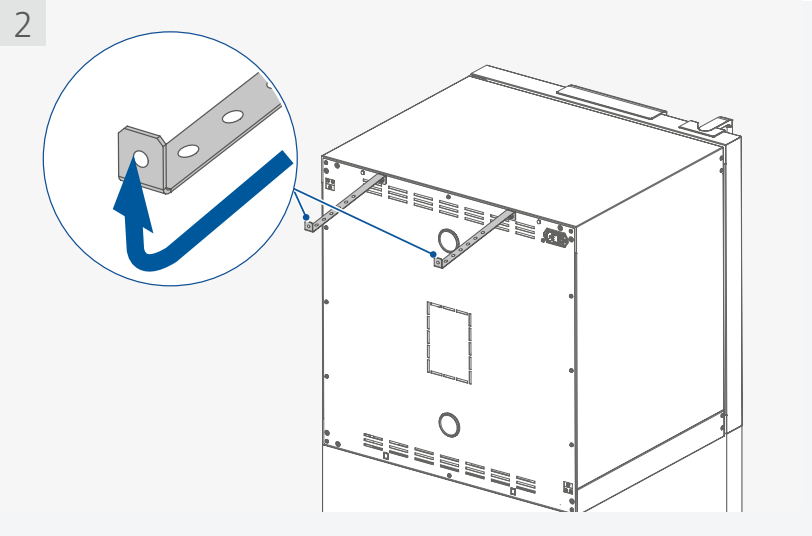

Note:

- › The screws used for fixing is selected according to the wall conditions and is not included.
- › Note the further installation instructions on stacking two devices.

/// Placing the drain hose in laboratory drain

- › Detach the end of the hose from the holder

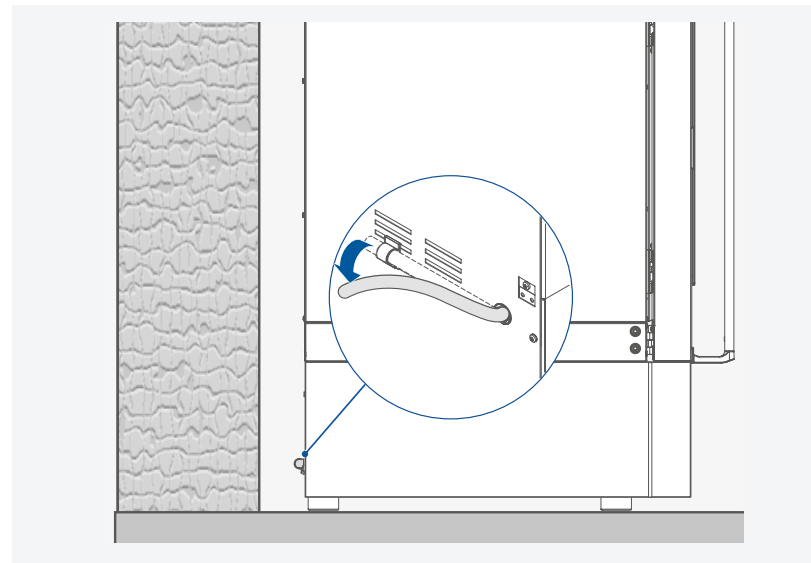

- › Extend the drain hose as required using the enclosed hose adapter

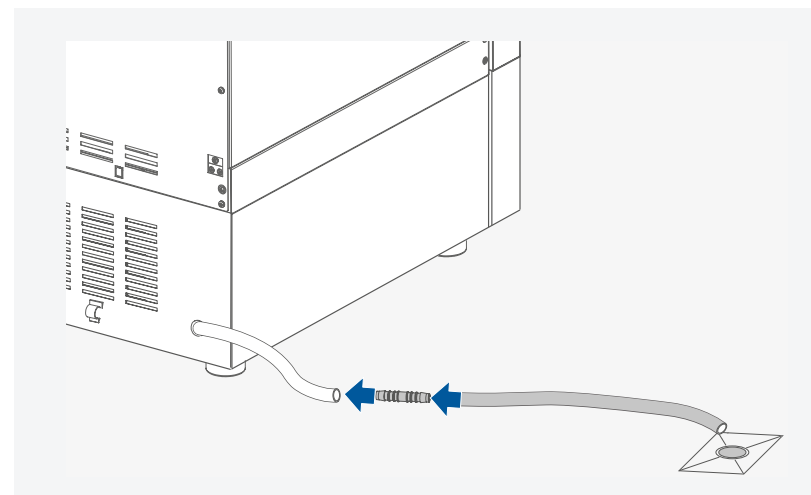

In the event of glass vessels breakage, the leaked liquid or water caused by condensation or defrosting is collected by the drain pan (not included in delivery scope) below the shaking platform and is directed to the drain hose at the rear of the device. Place the drain hose in the laboratory drain.

Note: The extension hose is not included in delivery scope.

/// Inserting the shaking platform and shelf

- › Open the door

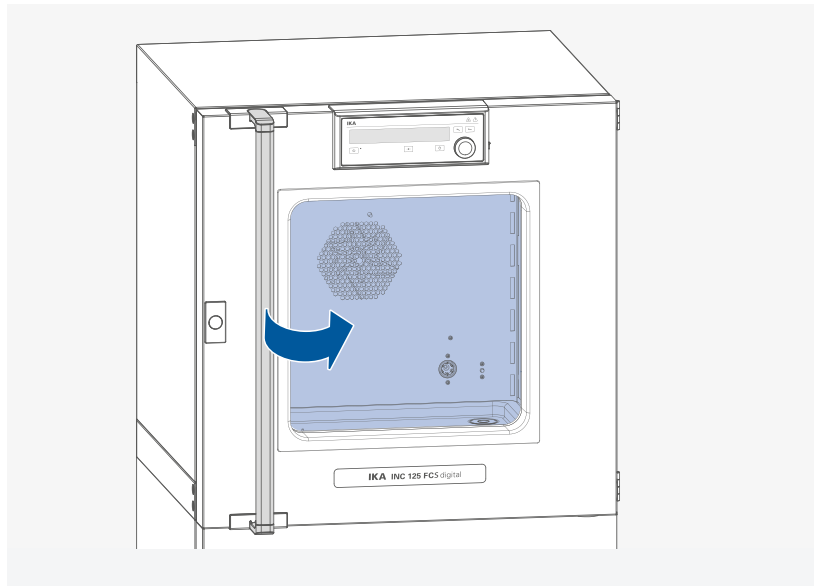

- › Insert the shaking platform

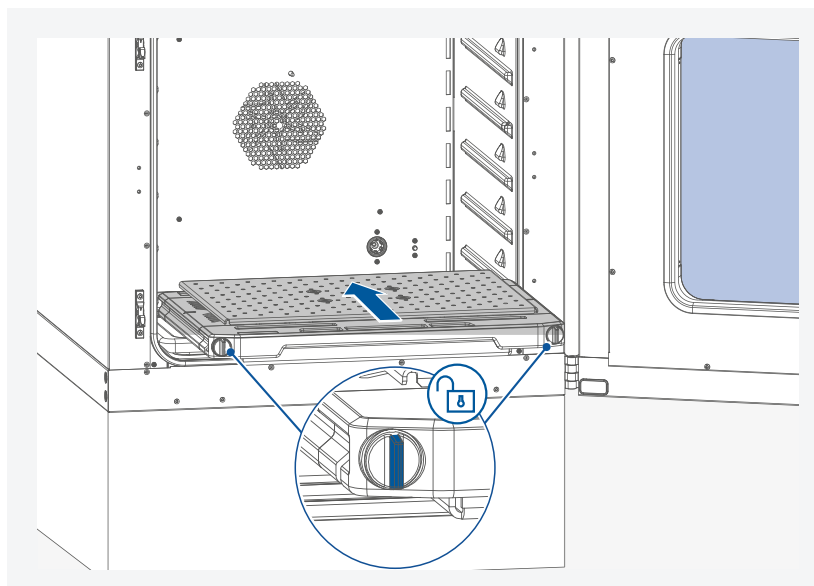

Note: When assembling the shaking platform, ensure the shaking platform locking knobs are turned to unlock status.

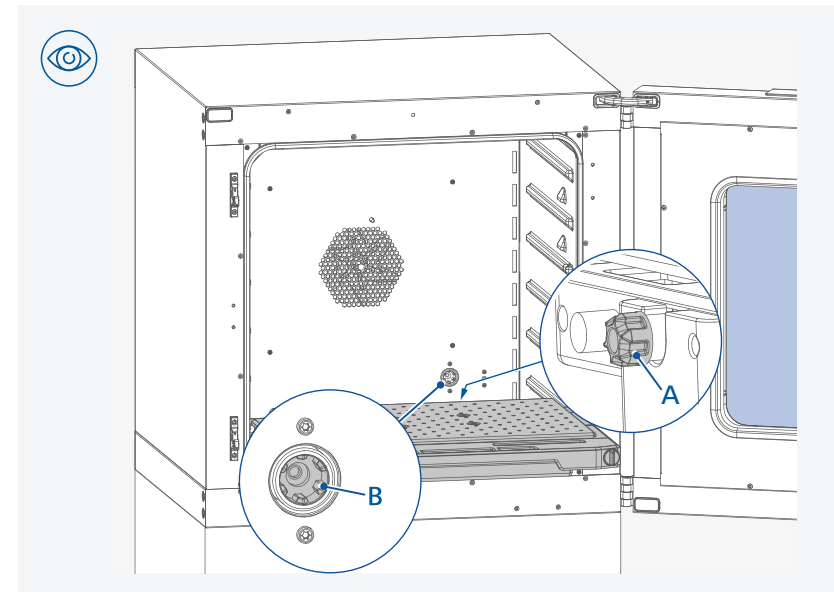

Note: When assembling the shaking platform, ensure the shaking platform coupling (A) is inserted into the coupling (B) correctly in the device.

- › Lock the shaking platform

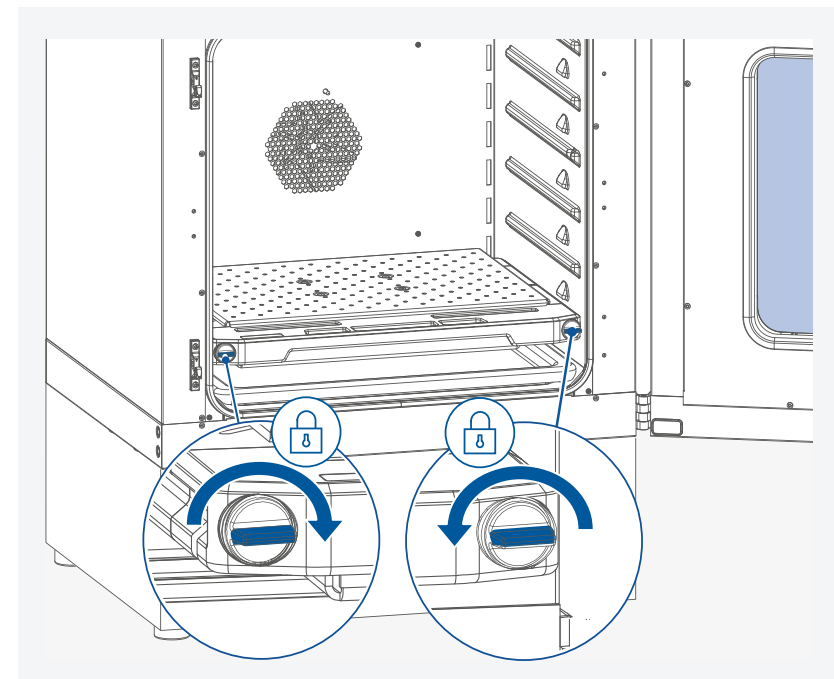

› Insert the shelf

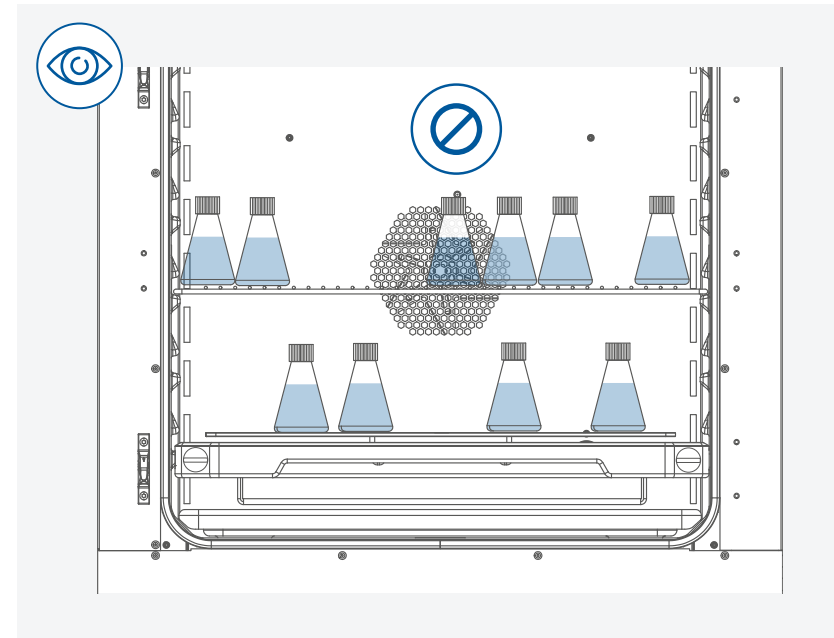
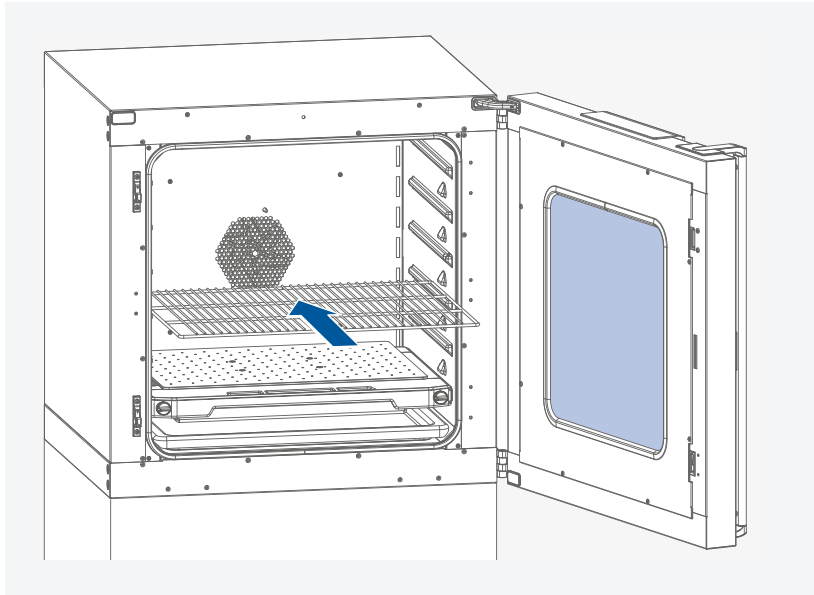

/// Correctly loading

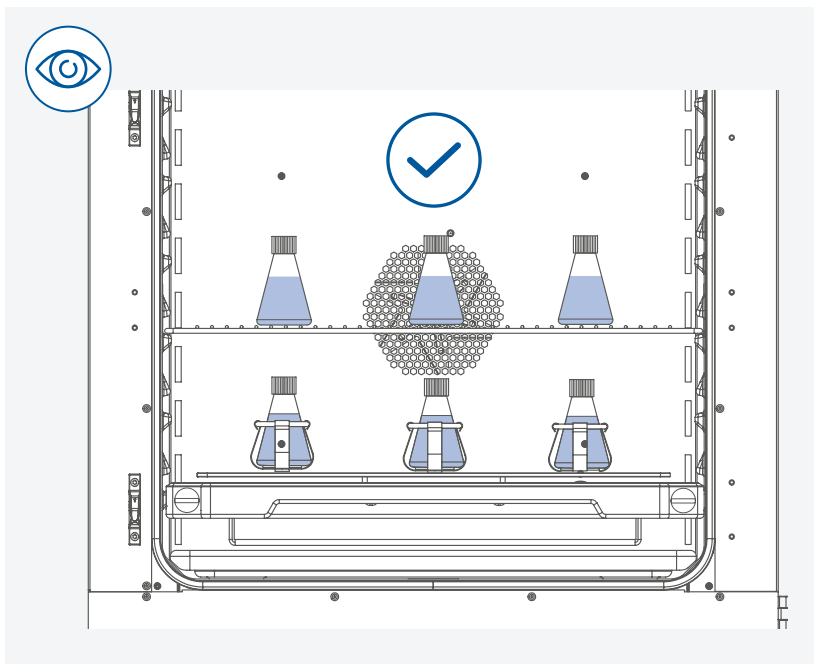

Note:

- › Don't load sample directly on the shaking platform. Use fixing clamps or the STICKMAX adhesive mat to hold vessels.
- › Keep distance between samples and hot inner surface. Temperature of the inner wall may be much higher than set temperature.
- › Ensure sufficient air circulation in the chamber by not placing the sample too close.
- › If the device comes from a cooler environment and is switched on immediately, condensation may form on the inside of the chamber. Therefore, wait one hour before switching on the device so that it can adjust to the ambient temperature.

For loading, pull out the shaking platform to a maximum of halfway.

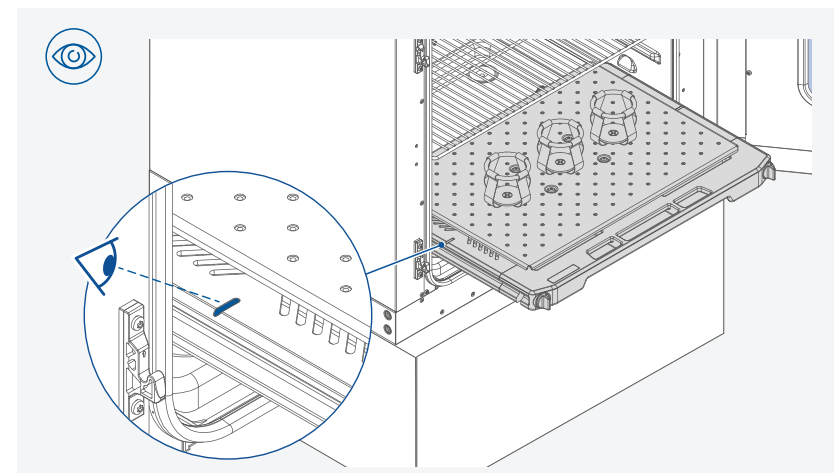

/// Connecting to power

⚠ Notice!

The socket used must be earthed (fitted with earth contact).
Observe the ambient conditions (temperature, humidity etc.) listed under "Technical Data".

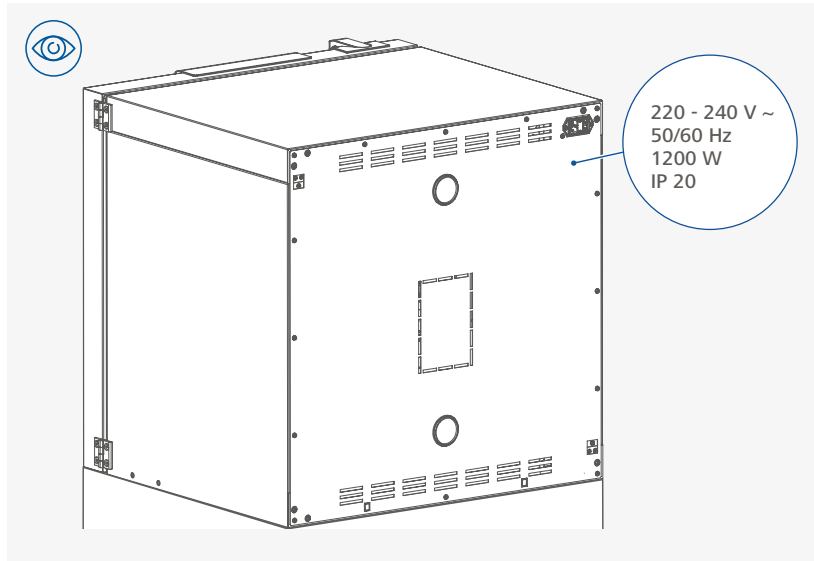

⚠ Notice!

The voltage stated on the type plate must correspond to the power voltage.

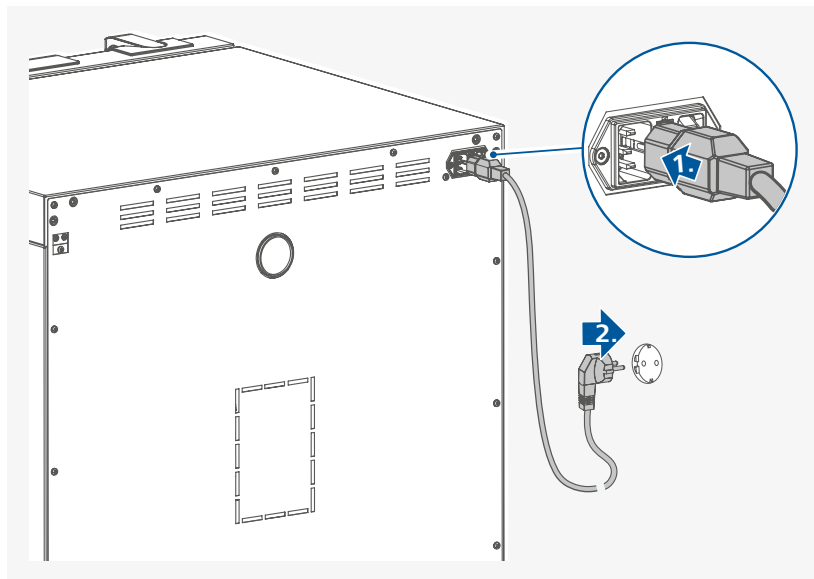

/// Other installation information (Stacking two devices)

- > Attach the lower device to the wall (see section "Setting up / Fixing the device to the wall").
- > Place the second device, **INC 125 F** or **INC 125 FS digital** on top of the first.

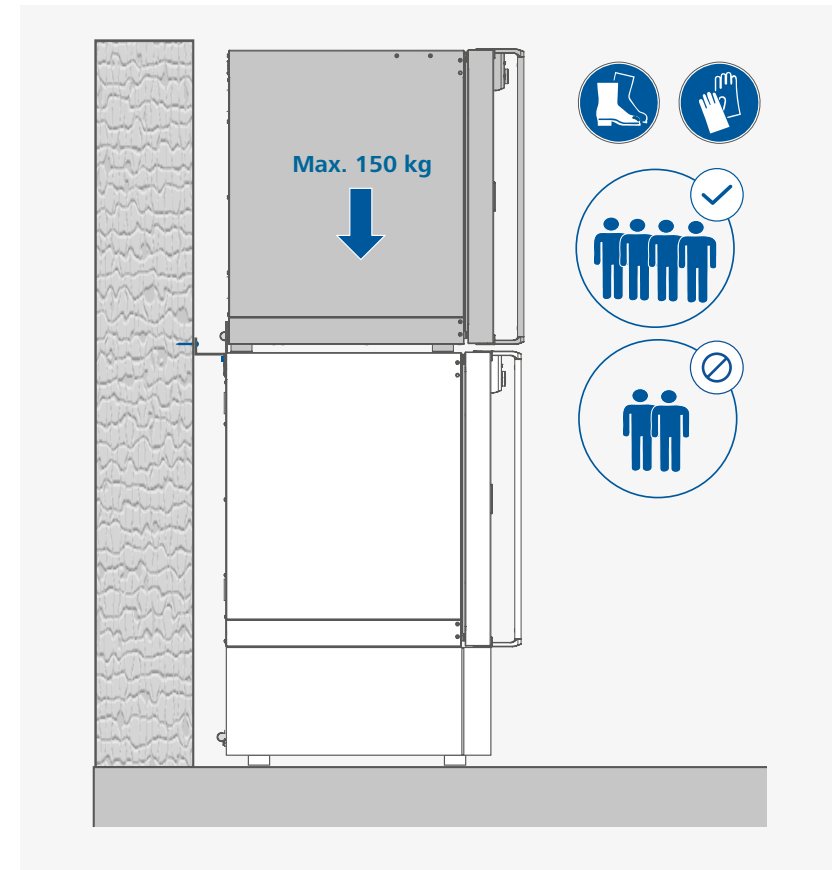

⚠ Caution!

- > When stacking the device, four persons are required to lift it.
- > Never stack more than two devices.

› Attach both devices together

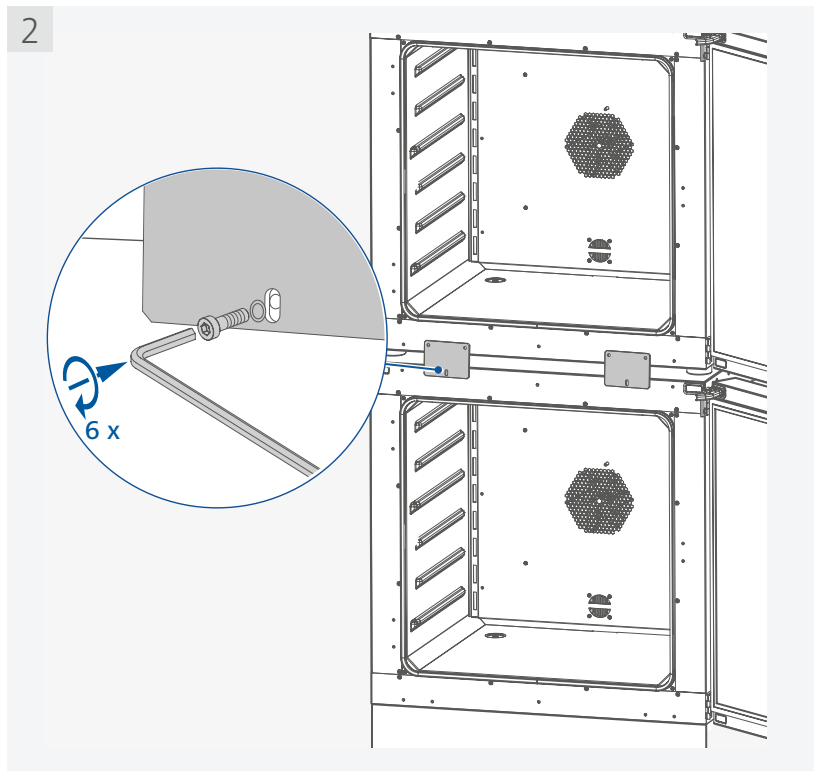
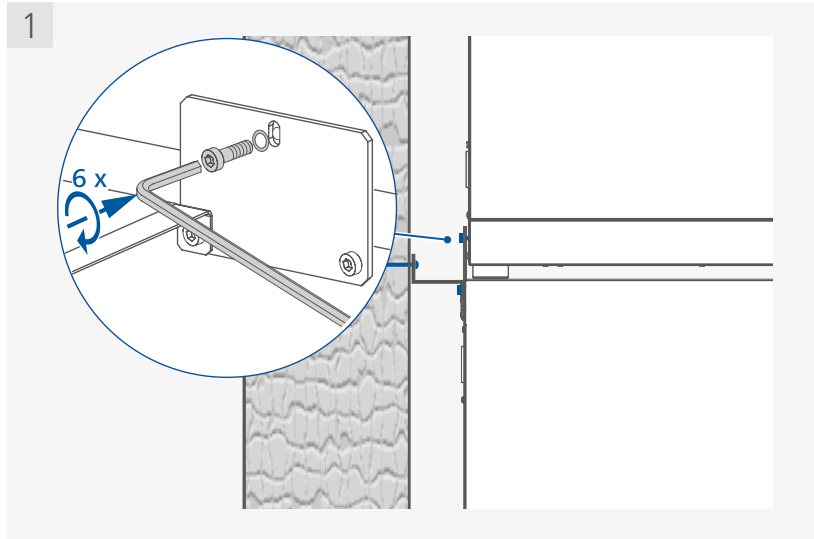

› Attach the upper device to the wall

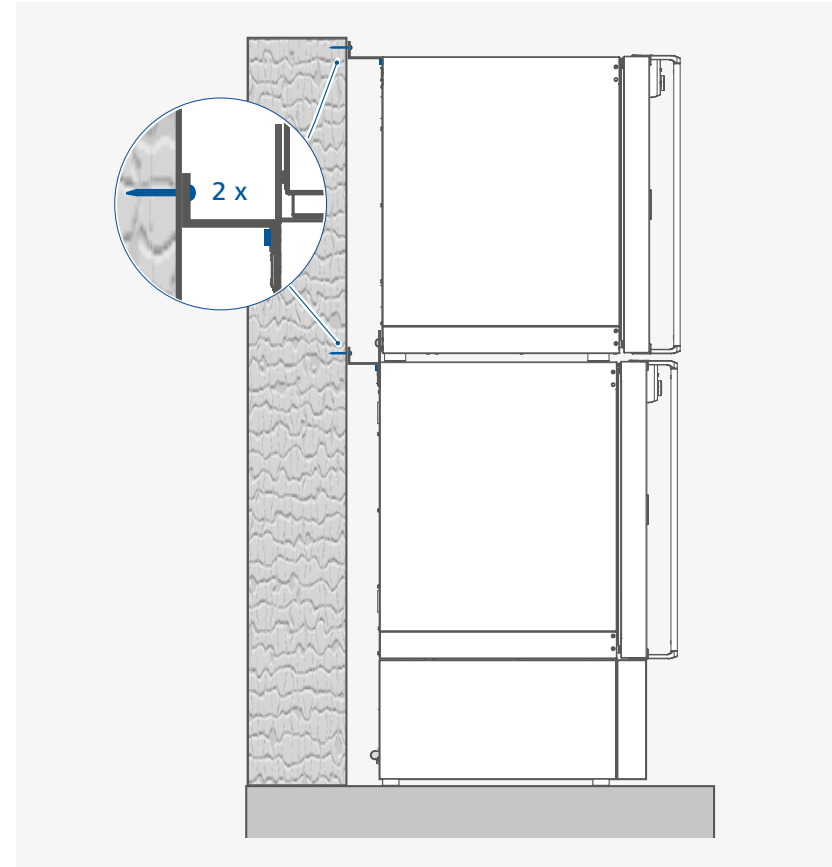

Note:

- › The screws used for fixing is selected according to the wall conditions and is not included.
- › The stacking kit is not included. Please order it separately.

› Placing the drain hoses in laboratory drain

Detach the end of the hose from the holder

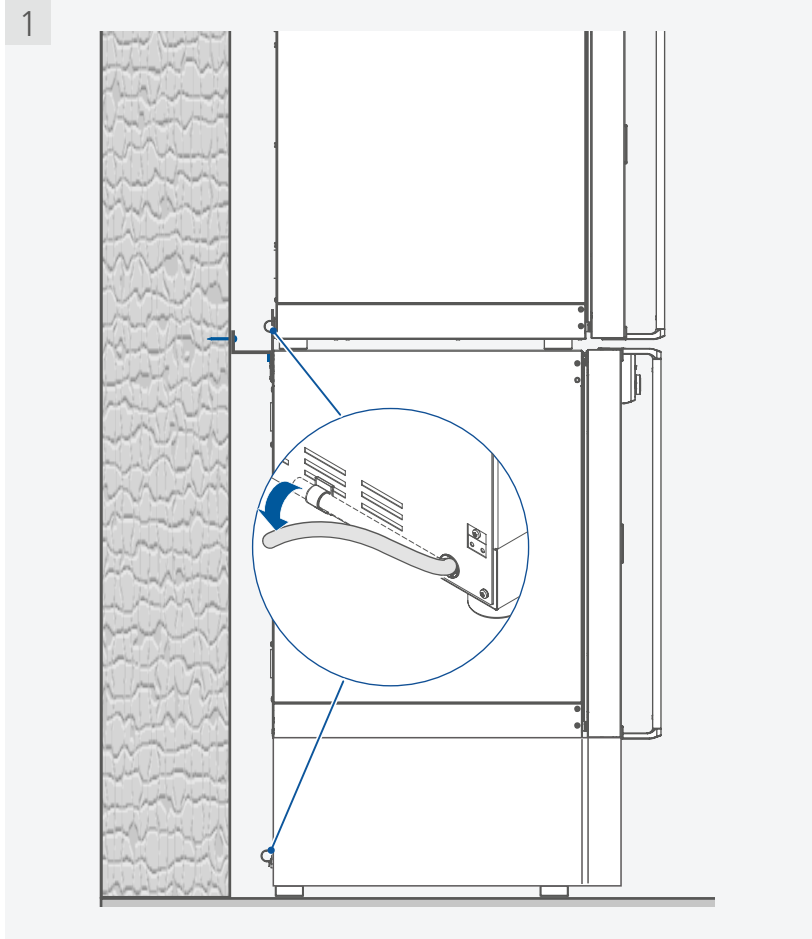

Extend the drain hose as required using the enclosed hose adapter

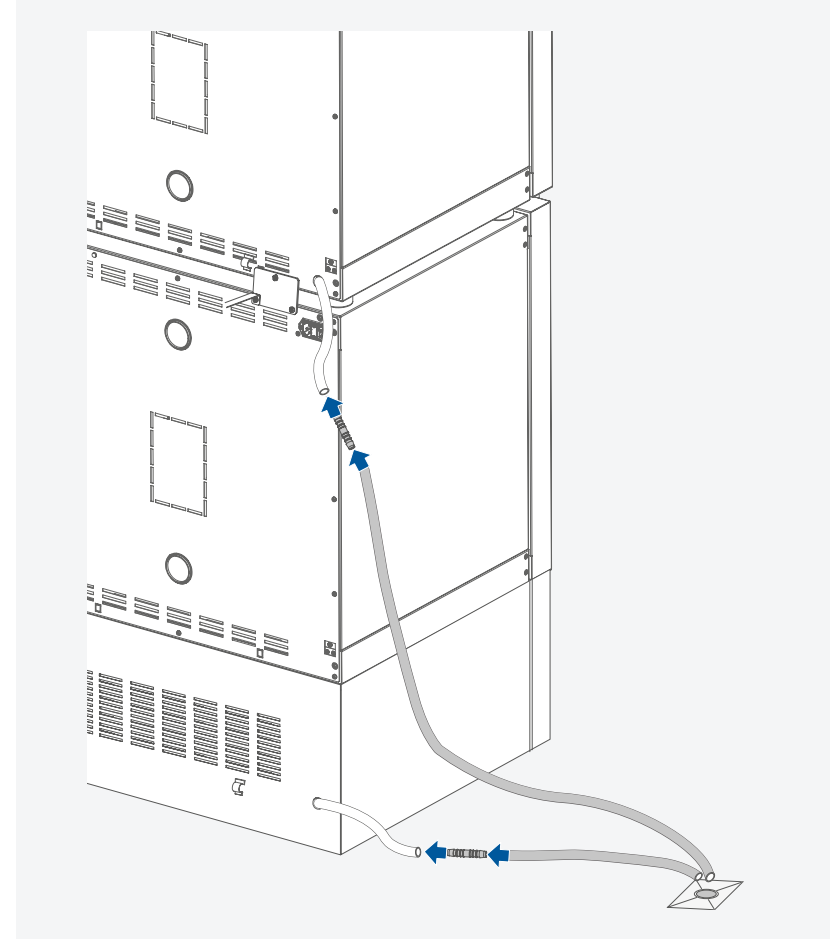

The devices drain hoses must be guided to the laboratory drain with the hose adapters and extension hoses.

Note: The extension hoses are not included in delivery scope.

Operator panel and display

/// Explanation of the control elements

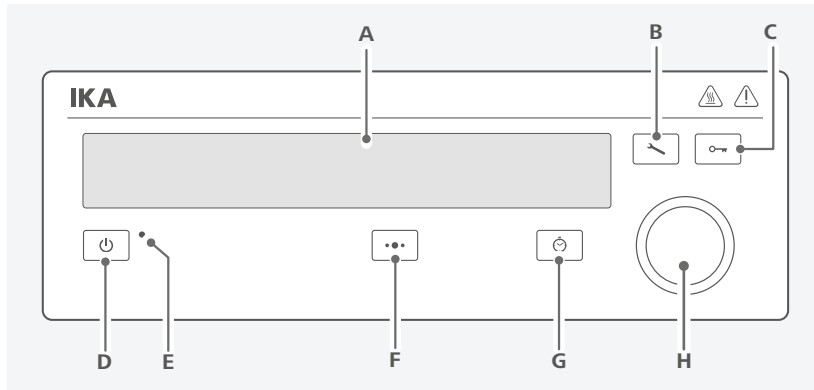

Item	Designation	Function
A	Display	Screen.
B	Menu button	Opens the menu (press and hold the button for 2 seconds). Closes the menu (press and hold the button for 2 seconds).
C	Lock button	Lock/unlock the settings.
D	Standby button	Switches the device to standby mode (no disconnection from the power supply).
E	Standby LED	Indicate that the device is in standby mode.
F	Multifunction button	Switch between fan (FAN), light (LIGHT) and shaker (SHAKE) setting.
G	Timer button	Switch between the "Counter (C)", "Timer (T)" and "Timer Auto (Ts)" setting.
H	Control knob (rotating / pressing)	Adjust the temperature setting. Set the fan speed (%). Adjust the time value in Timer (T) or Timer Auto (Ts) function. Navigation, selecting and changing the settings. Start / stop running of the device.

/// Explanation of symbols on the working screen

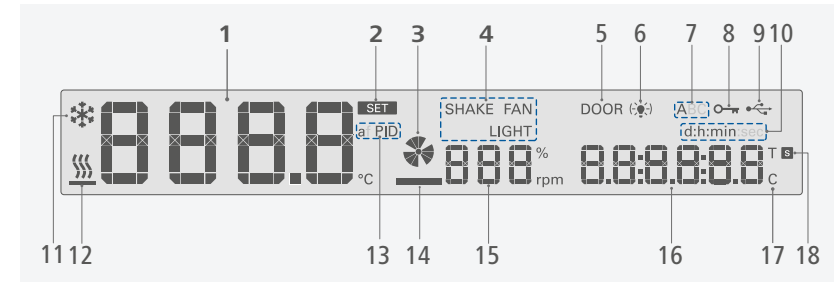

Item	Designation	Function
1	Temperature value	Display the settings and actual temperature value.
2	"SET" symbol	Indicate that the set temperature value is displayed.
3	Fan status symbol	Indicate the fan is activated/deactivated.
4	SHAKE/FAN/LIGHT symbol	Indicate the selected function (shaker/fan/light).
5	Door symbol	Indicate the door is opened.
6	Light symbol	Indicate the light is activated.
7	Operating mode symbol	Indicate the device is in operating mode (A, B or C).
8	Lock button symbol	Indicate the settings of the device is locked.
9	USB connection symbol	Indicates a USB cable is connected.
10	Time range	Indicate the selected timer / counter range ([d:h:min] or [h:min:sec])
11	Cooling Symbol	Indicate the cooling function is activated.
12	Heating Symbol	Indicate the heating function is activated.
13	Temperature control symbol	Indicate the selected temperature control mode (a PID or f PID).
14	Shaking platform symbol	Indicate the shaking platform is assembled.
15	SHAKE/FAN speed	Display the shaking speed (rpm) or fan speed (%).
16	Timer/counter value	Display the timer/counter value.
17	Counter symbol	Indicate the counter is activated.
18	Timer symbol	Indicate the timer is activated.

Note: The symbols displayed change depending on the status and settings of the device.



Operation

⚠ Notice!

Before commissioning, make sure that the device has not been moved in one hour.

/// Switching on

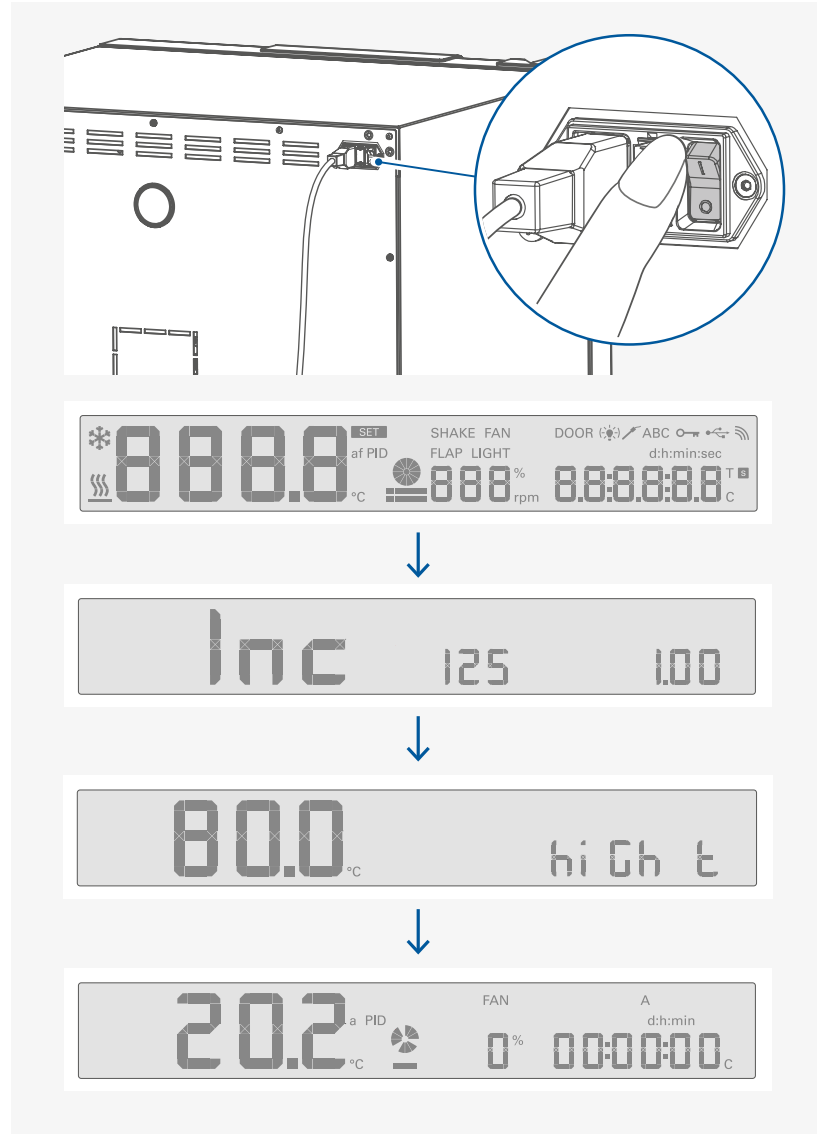

/// Setting the temperature

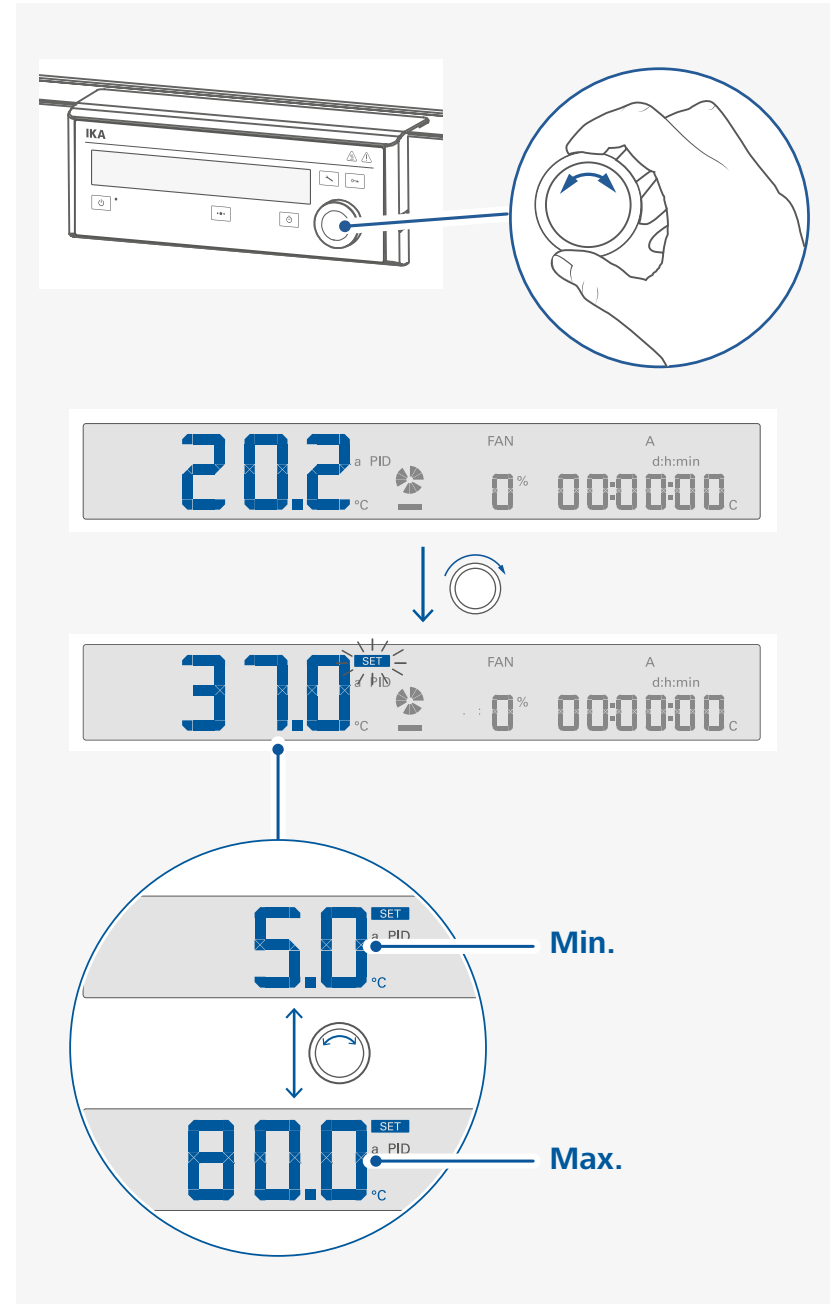

/// Setting the fan speed / light / shaking speed

› Switch between fan / light / shaker

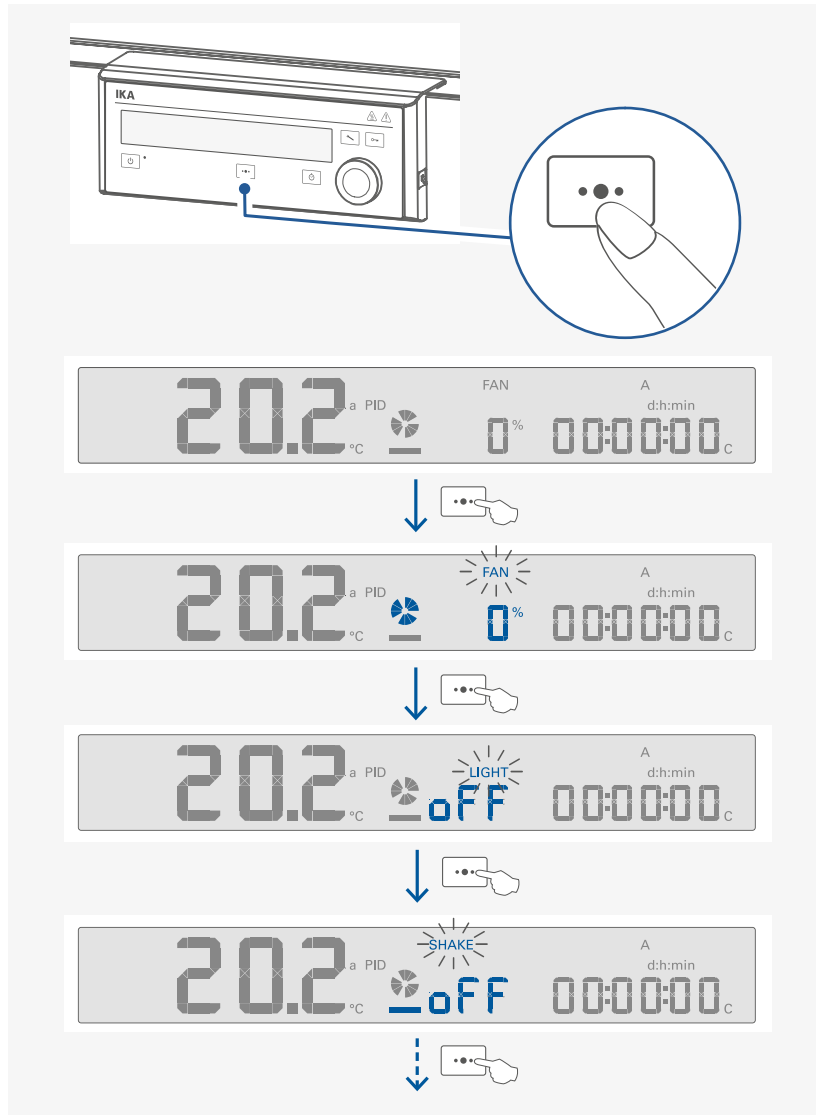

Note: Switching between the fan/light and shaking speed by touching the multifunction button (F). The selected function blinks. Then, the value can be adjusted respectively by rotating the control knob (H).

› Set the fan speed

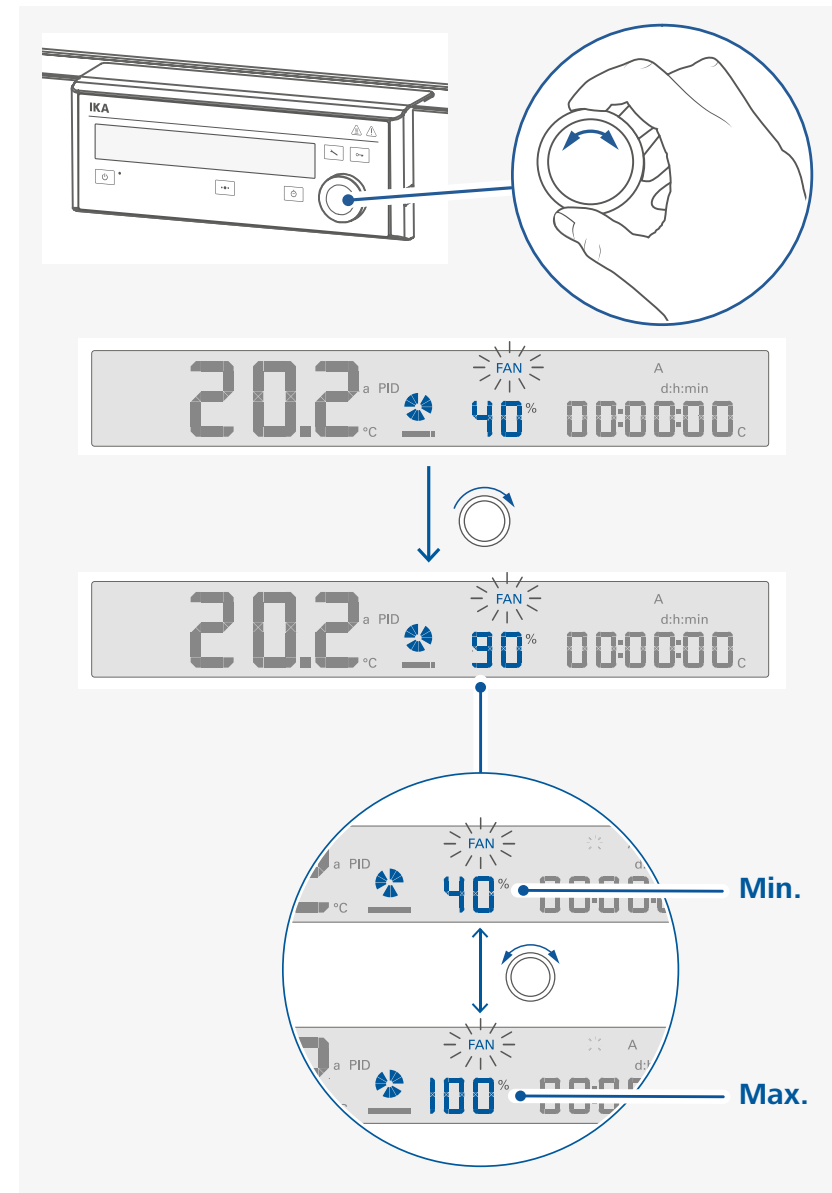

Note:

- › The fan speed can be adjusted from 40% to 100%.
- › The fan speed can also be changed when the tempering function is activated.
- › Higher fan speed can improve the temperature homogeneity in the chamber.

› Confirm the setting of the fan speed value and start the fan

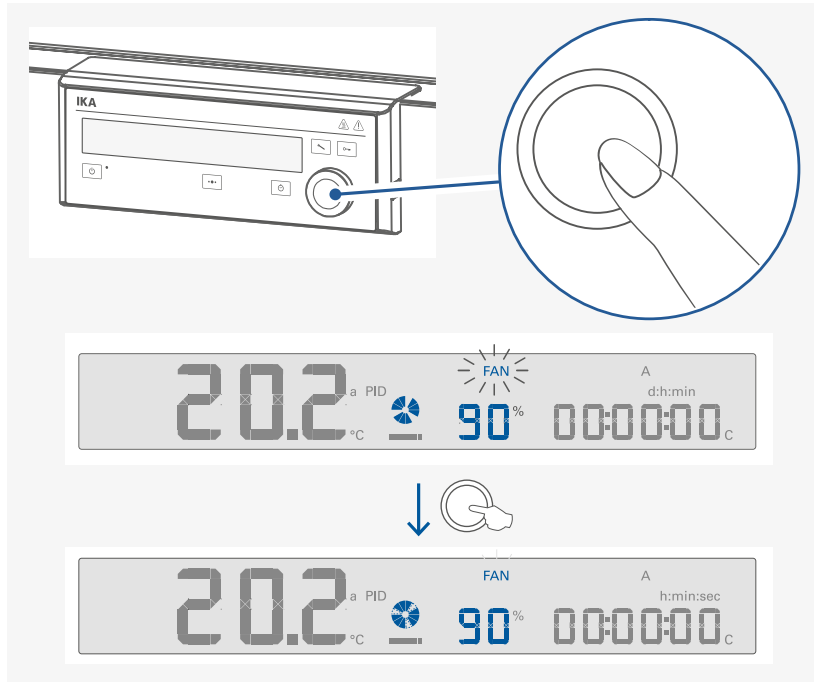

› Set the light status

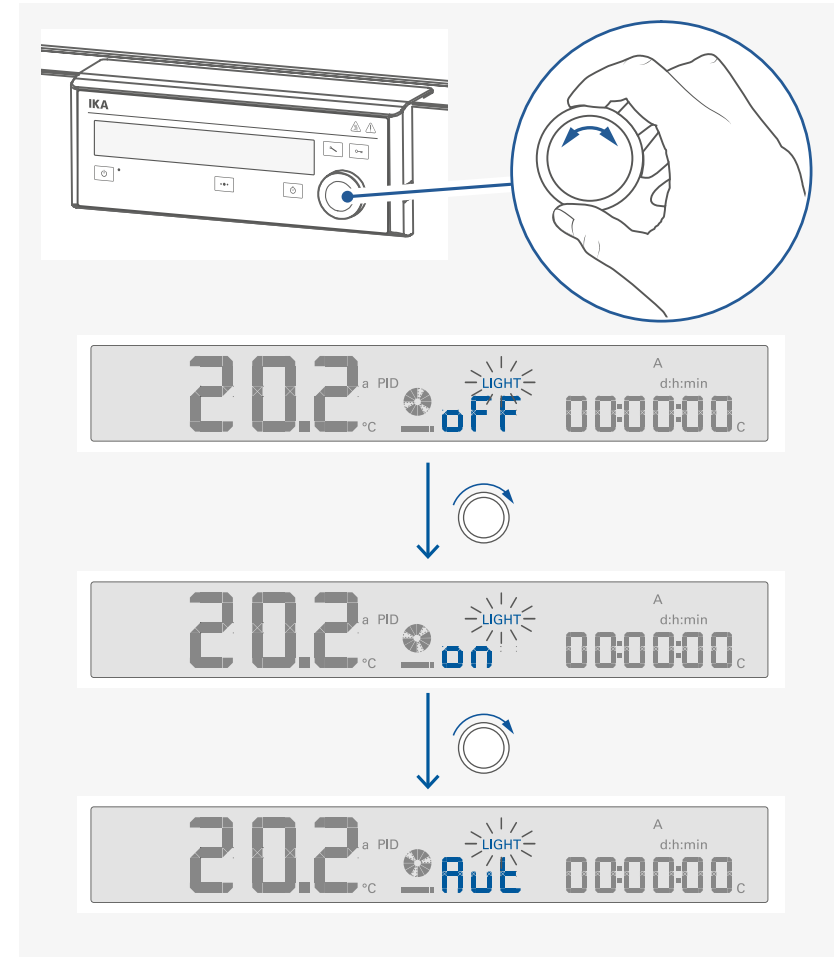

Note: The light status can also be changed during operation.

› Confirm the light status and activate the light

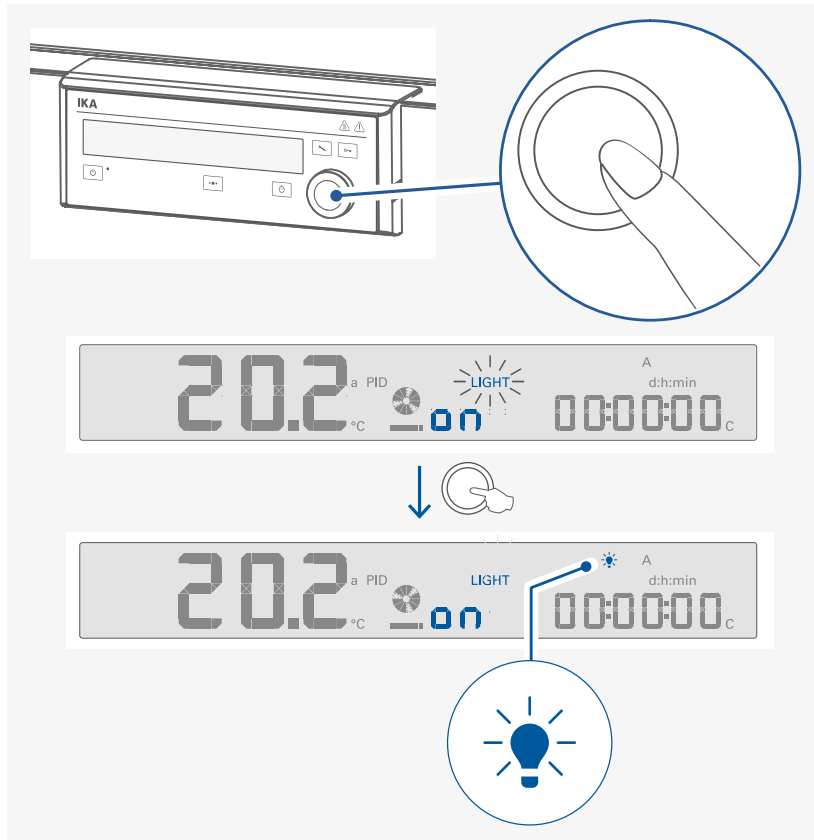

Note:

☀ indicates the light is set to "on" status.

☀ indicates the light is set to "Auto (Aut)" status. When the door is opened, the light is switched on automatically and this symbol appears.

› Adjust the shaking speed

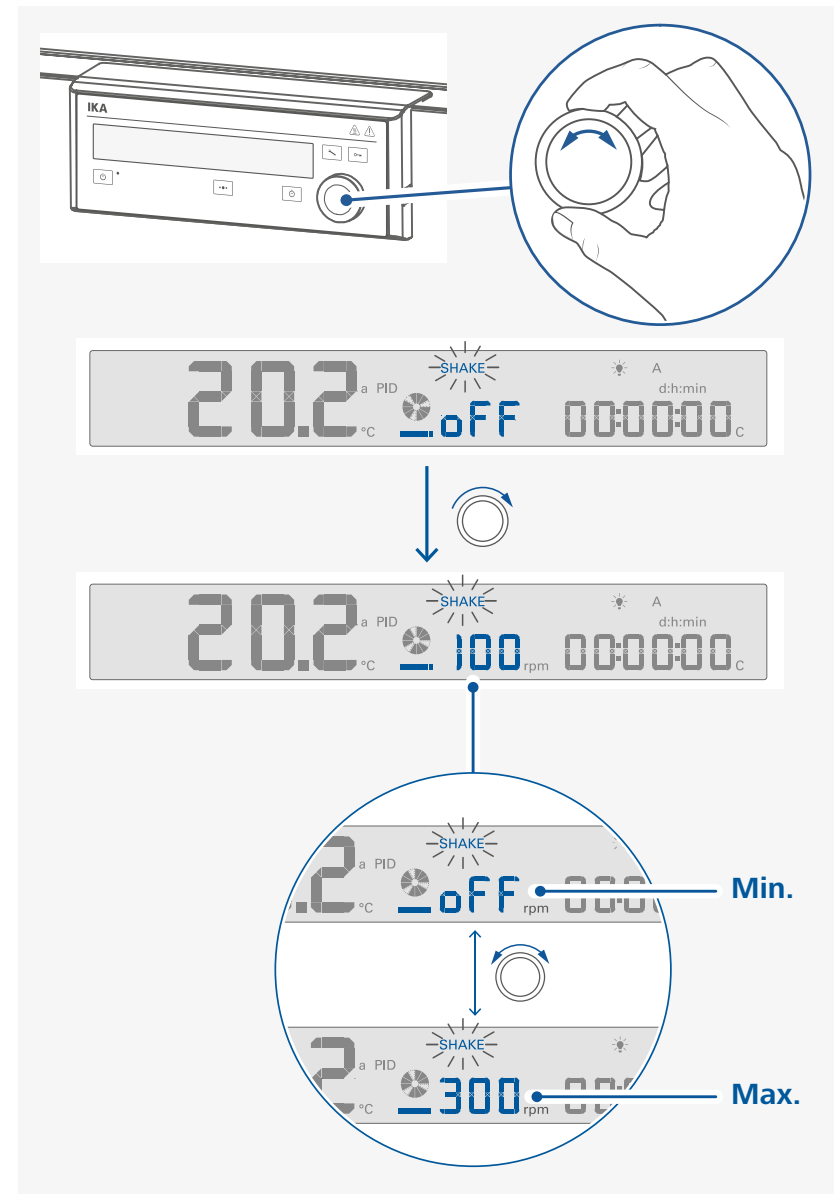

Note: The shaking speed can also be changed when the device is running.

> Confirm the shaking speed

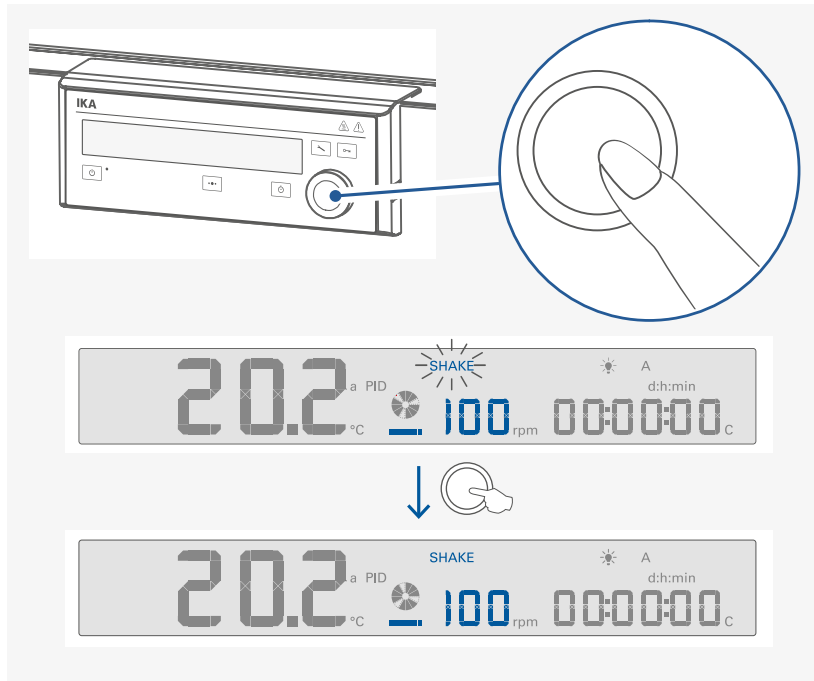

/// Setting Counter (C) / Timer (T) or Timer Auto (Ts)

> Switch between Counter (C) / Timer (T) / Timer Auto (Ts)

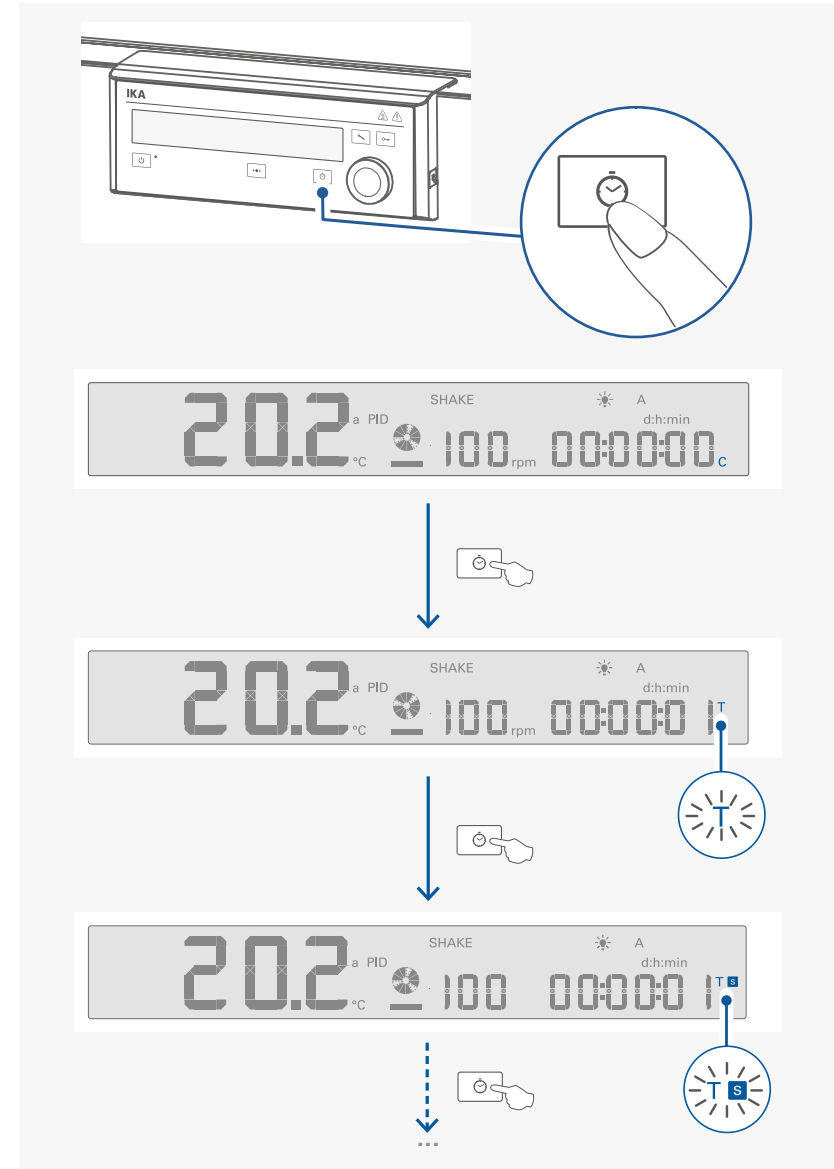

› Adjust and confirm the Timer (T) or Timer Auto (Ts) value

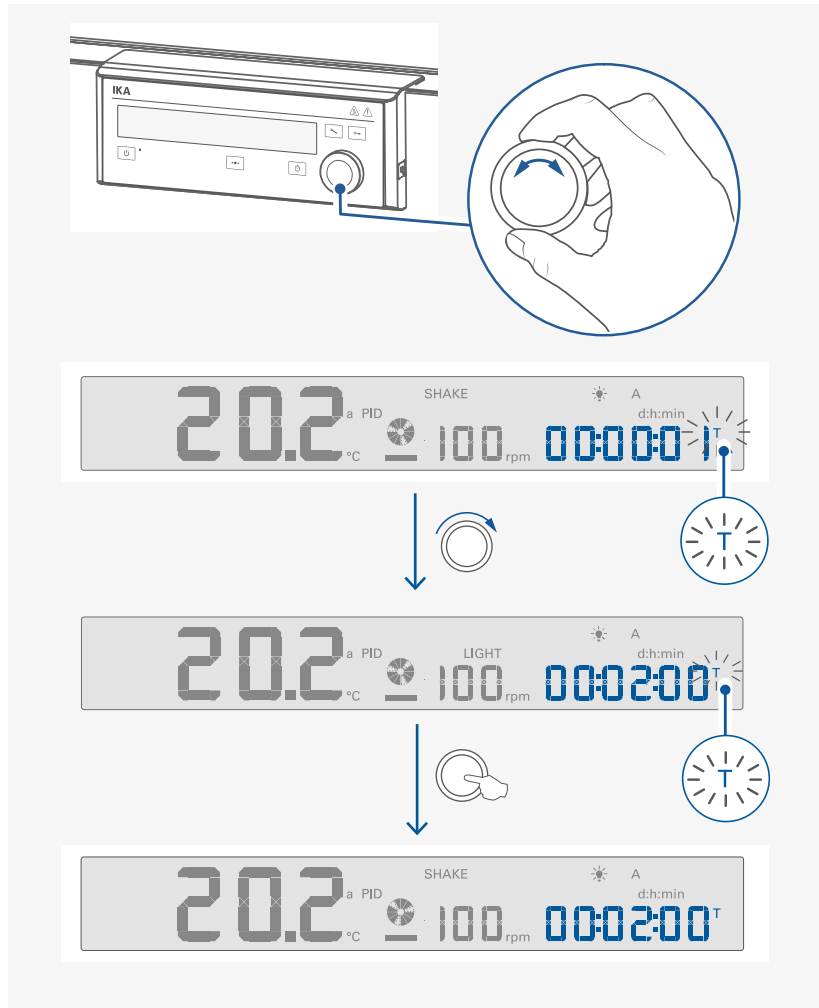

/// Starting tempering / shaking function

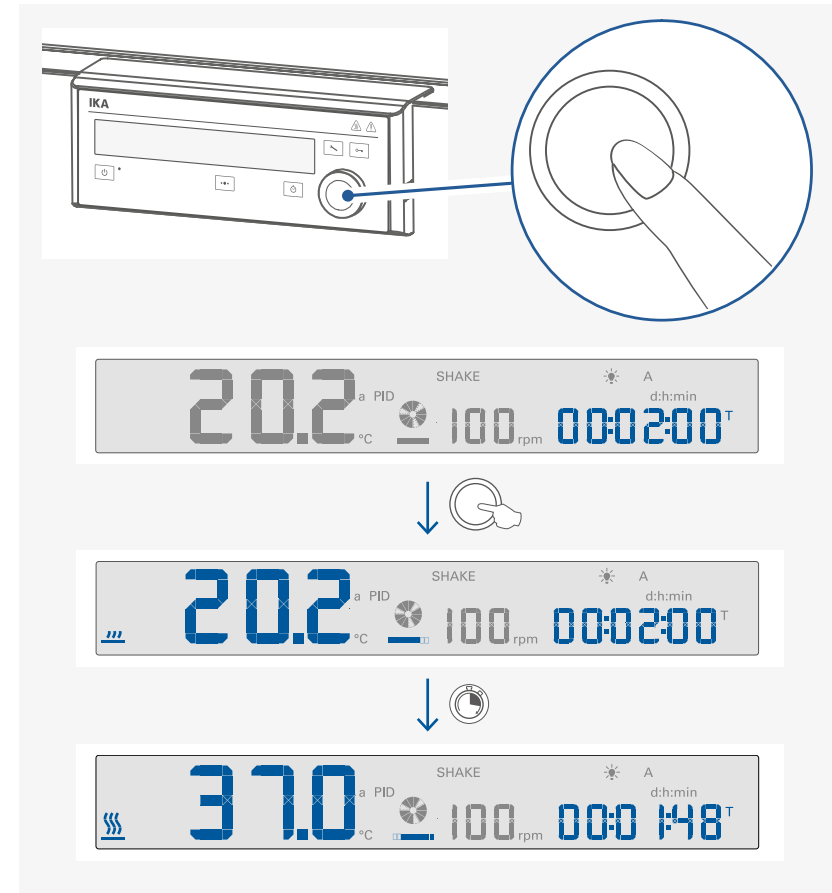

Note: At set temperatures below the ambient temperature, the cooling unit switches on automatically. Please note that ice may form in the interior during cooling mode.

Note:

Counter (C):

- › If the "Counter (C)" function is activated, the counter automatically starts to run from 00:00:00 [h:min:sec] to the maximum value (99:23:59 [d:h:min]) when the tempering function is started.
- › If the device running time exceeds 24 hours, the time range switch from [h:min:sec] to [d:h:min] automatically.
- › If the tempering function of the device is stopped during a "Counter (C)" process, the run time is shown on the display.

Timer (T):

- › If the "Timer (T)" is set and activated, the timer automatically starts to count down from the set timer value. When the timer reach 00:00:00 [h:min:sec], the device stops tempering function and last "Timer (T)" setting is shown on the display.

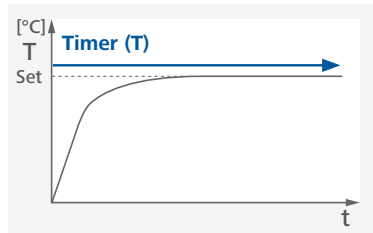

Timer Auto (Ts):

- › If the "Timer Auto (Ts)" is set and activated, the timer only starts to count down from the set timer value when the set temperature (tolerance: ± 1 K) is reached. When the timer reach 00:00:00 [h:min:sec], the device stops tempering function and last "Timer Auto (Ts)" setting is shown on the display.
- › When the device is set to "Timer Auto (Ts)" mode, the display shows "WAit (uR it)" until set temperature value is reached.

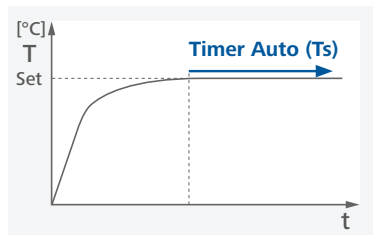

/// Locking / unlocking the settings

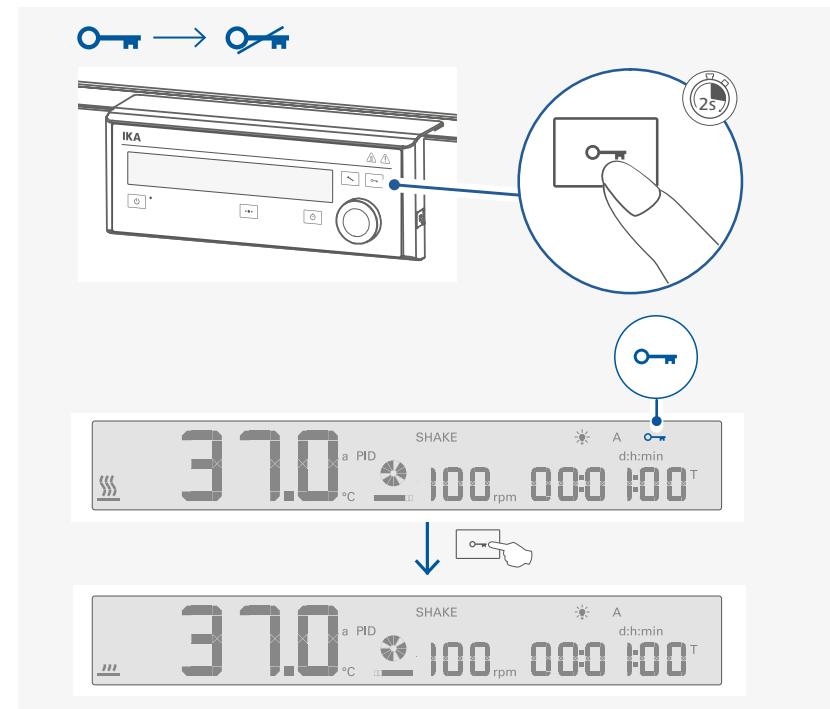
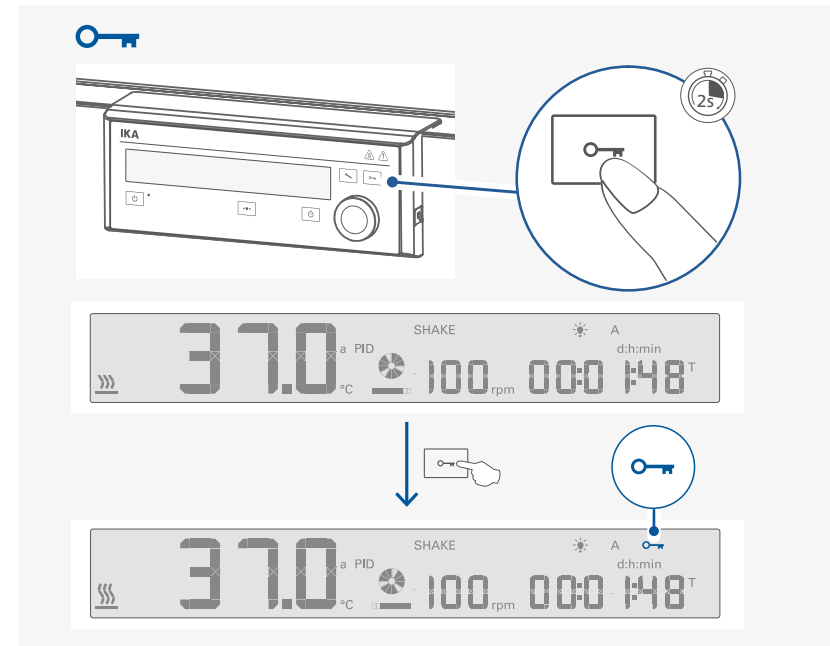

/// Stopping tempering / shaking function

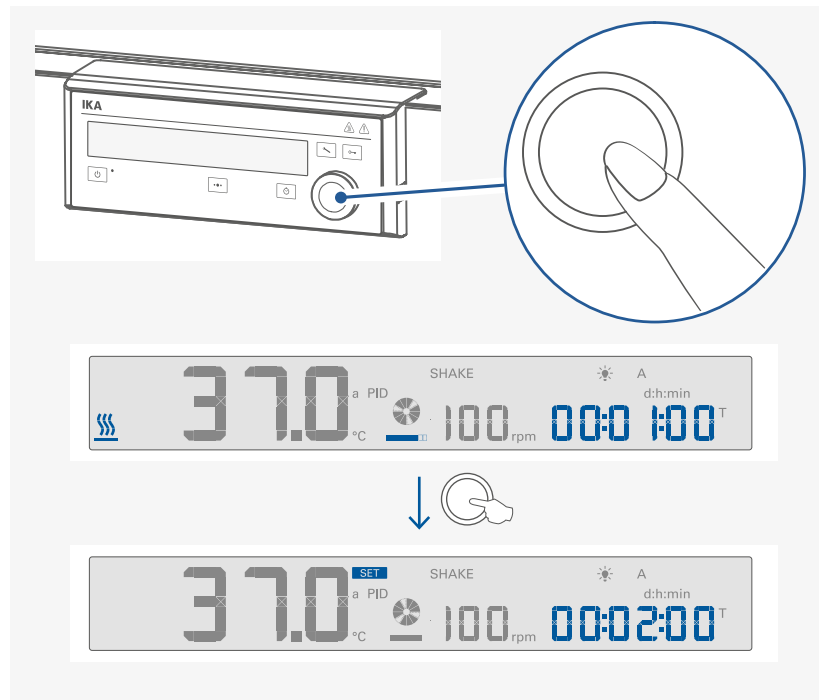

/// Activate standby status

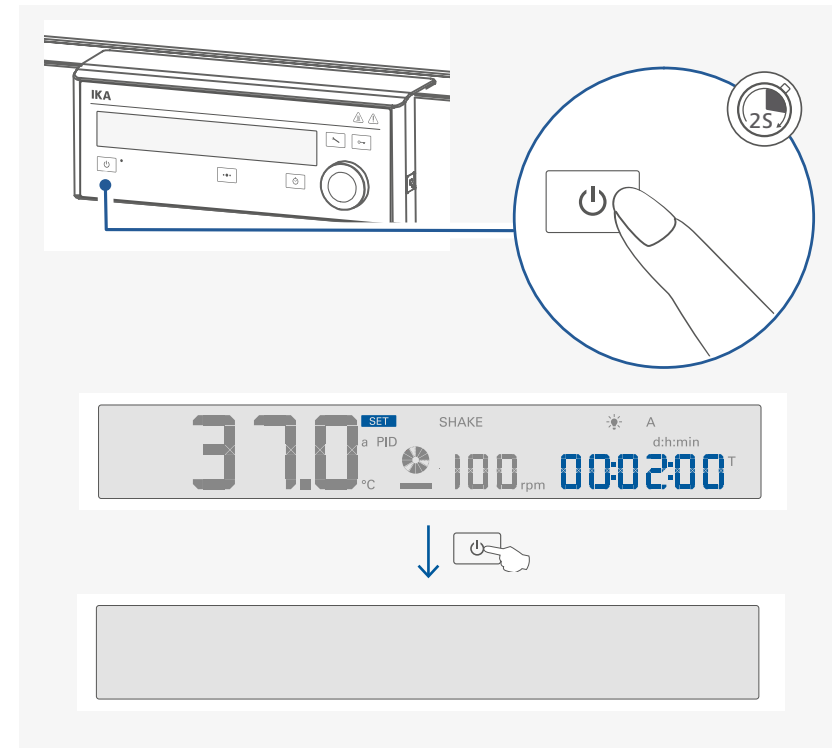

Note: When switching the device to standby status, if the device chamber temperature is higher than 50 °C, the actual temperature is displayed, e.g. 70 °C and "hot" symbol blinks.

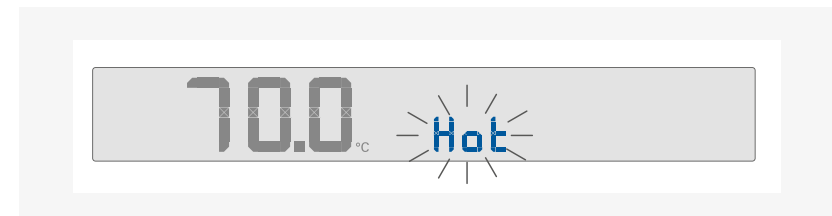



















Menu navigation and structure

/// Menu navigation

- › Press the menu button (B) for 2 seconds.
- › Select the desired menu or sub-menu by turning the control knob to left or right and then pressing the control knob.
- › Press or turn the control knob again to select the desired menu option and edit the values or settings, or activate / deactivate a function.

/// Menu structure

		Default settings
Menu	Operating mode	A ----- Activated B ----- C -----
	Temperature control mode	a PID (Accurate PID) ----- Activated f PID (Fast PID) -----
	Time range	h:min:sec ----- d:h:min ----- Activated
	Alarm and key tone	BEEP (on) ----- Activated 
		BEEP (off) ----- 
	Temp limit ----- 80 °C 	
	Temperature alarm	Temperature alarm (on) ----- Activated 
		Temperature alarm (off) ----- 
	Factory reset	Factory reset (yes) ----- 
		Factory reset (no) ----- Activated 
	Decontamination	Decontamination (off) ----- Activated 
		Decontamination (on) ----- 
	Defrosting	Defrosting (off) ----- Activated 
		Defrosting (48 hours) ----- 
		Defrosting (24 hours) ----- 
		Defrosting (12 hours) ----- 
	Calibration and adjustment	Calibration (off) ----- Activated 
		1-point calibration ----- 
		2-point calibration ----- 
		3-point calibration ----- 
		Reset calibration ----- 

/// Menu details

Operating mode:

In this menu item you can choose between three different operating modes.

Mode A: All settings will be stored if the device is switched off or disconnected from the power supply. The tempering/shaking function will be set to off when the device is powered on.

Mode B: All settings will be stored if the device is switched off or disconnected from the power supply. The tempering/shaking function will be set to on or off when the device is powered on, depending on the previous status of the device.

Mode C: In Mode C the device behaves the same as in mode B and all settings cannot be changed.

Temperature control mode:

In this menu option, you can select between two PID control modes:

a PID (Accurate PID):

For using with temperature sensitive materials that must be handled with care.

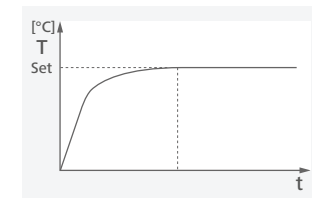

Advantages:

- Accurate temperature control.
- Minimum deviation above/below the target temperature.

Disadvantage:

- Longer heating up time.

f PID (Fast PID):

For use when a fast heating up time is needed and there should then be precise temperature control.

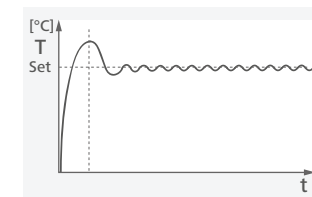

Advantages:

- Short heating up time.

Disadvantage:

- There will be a certain level of deviation above and below the target temperature.

Time range:

In this menu option, you can select time range [h:min:sec] or [d:h:min] as your request.

Note: In Counter (C) mode, if the time exceeds 24 hours, the time range will automatically switch from time range [h:min:sec] to [d:h:min].

Alarm and key tone:

In this menu option, you can select and activate alarm and key tone.



Beep (on): alarm and key tone is activated.



Beep (off): no alarm and key tone.

Temperature limit:

In this menu option, you can set the temperature limit from 20 °C to 80 °C for the device.



The set temperature limit must be at least 25°C below the flash point of the medium in use (EN 61010-2-010).

Note: If the set temperature limit is exceeded by 20K, the tempering switches off and an error message is displayed.

Temperature alarm:

In this menu option, you can select to activate or deactivate the temperature alarm function.



Temperature alarm (on): Temperature alarm is activated.

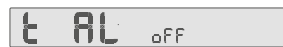

Temperature alarm (off): Temperature alarm is deactivated.

Note: After reaching the setpoint, if the temperature deviates from the setpoint by more than 3 °C for more than 20 minutes, or the temperature does not reach the tolerance range within 3 hours after activating the tempering function. If an alarm occurs, "t AL" is shown on the display. Acknowledge the message by pressing the multifunction button.

Factory reset:

In this menu option, you can reset device settings to factory settings.



Factory reset (yes): Resetting to factory settings



Factory reset (no): Without resetting to factory settings.

Decontamination:

In this menu option, you can perform decontamination to the chamber of the device.



Decontamination (off): Deactivate the decontamination function.



Decontamination (on): Activate the decontamination function.

Note: Before decontamination, the drip pan, shaking platform, all heat-sensitive and all flammable goods must be removed from inside.

When activating the decontamination function, the device will perform hot-air decontamination at 100 °C for 2.5 hours as following:



When the decontamination process is finished, the "dcon done" appear on the display and a "beep" sound is heard.

Press control knob to confirm it and screen back to "dcon off" as below:



Press menu button to go back to the working screen.

Note: The decontamination process can be stopped by pushing the control knob for 2 seconds. The "dcon StoP?" appear on the display as below:



Confirm to stop the decontamination by pushing the control knob again. The screen back to "dcon oFF" as below:



If the performing of decontamination is interrupted by power failure, the decontamination process will not restart again automatically. The "dcon FAiLEd" will appear on the display.



Defrosting:

In this menu option, you can deactivate or activate the defrosting function and set the defrosting time to every 48 hours, 24 hours or 12 hours.



Defrosting (off): Defrosting function is deactivated.



Defrosting (48): Defrosting function is activated and defrosting time is set to every 48 hours.

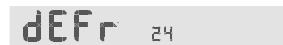

Defrosting (24): Defrosting function is activated and defrosting time is set to every 24 hours.



Defrosting (12): Defrosting function is activated and defrosting time is set to every 12 hours.

Note: If the ambient temperature and humidity are high, the defrosting time of every 12 hours may not be sufficient. In this case, you should carry out a manual defrost. Switch the heating to 35 °C for 30 minutes and the fan speed to 100%.

⚠ Notice!

Do not use mechanical devices or other means to accelerate the defrosting process, other than those recommended by the manufacturer.

In case of prolonged operation below the freezing point and frequent opening of the door, ice may form in the interior or on and in the glass door. When defrosting, the resulting water can be drained through the drain opening or removed with a towel.

Calibration:

The device is calibrated and adjusted in the factory.

Individual sample loading and ambient condition might influence the temperature behaviour of the chamber. You can select and make 1-point, 2-point or 3-point calibration and adjustment as necessary.

By using 3-point calibration to compensate that influence, the device can get the optimal result. This function allows the temperature to be calibrated and adjusted to three different temperature values.

When calibration, locate a calibrated reference measuring sensor at the center of the cabinet.



Calibration 1: 1-point calibration.

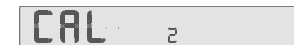

Calibration 2: 2-point calibration.



Calibration 3: 3-point calibration.



Calibration reset: Reset to original calibration.

Example: 2-point calibration and adjustment:

Switch to calibration screen by pressing menu button (B) and rotating the control knob (H). Following screen appears:



Press and rotate the control knob (H) to select 2-point calibration, following screen appears:

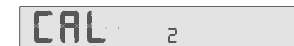

Press the control knob (H) to confirm the 2-point calibration, the first point calibration screen appears:



Rotate the control knob (H) to set the first point temperature (e.g. 25 °C), following screen appears:



Press the control knob (H) to confirm this step, "Yes" appears on the screen:



Press the control knob (H) again to start the first point calibration. The set temperature changes to the right side of the screen and actual temperature appears on the left side of the screen.



Wait for about one to two hours until temperature is stable (e.g. reach about 24.8 °C), the "SET" symbol appears and blinks. Meanwhile, a "beep" sound is heard.



Press the control knob (H), the "Ext" symbol appear:



Now you can input the measured value (e.g. 24.9 °C) from the external measuring device.



Press the control knob (H) to finish the first point calibration.



Then, the second point calibration screen appears automatically.



Perform the second point of the calibration in the same way as the first.

Note: The calibration can be cancelled in below steps:

- > Press control knob (H) for 2 seconds in calibration process.
- > "CAL StoP?" appear on the display.

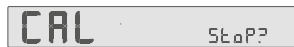

- > Press control knob (H) to stop the calibration.

Interfaces and outputs

The device can be connected to a PC and operated with the laboratory software Labworldsoft® through USB interface. The device software can also be updated with a PC via the USB port.

Note: Please comply with the system requirements together with the operating instructions and help section included with the software.

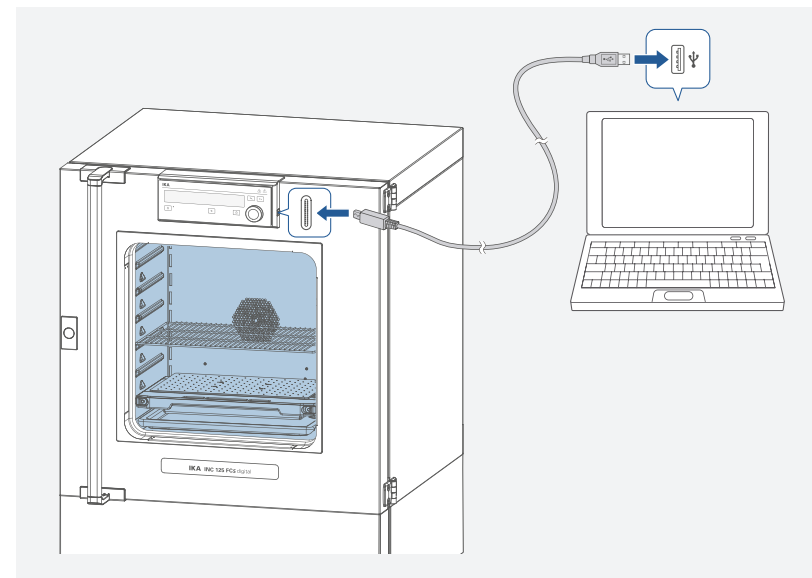

/// USB interface

The Universal Serial Bus (USB) is a serial bus for connecting the device to the PC. Equipped with USB devices can be connected to a PC during operation (hot plugging). Connected devices and their properties are automatically recognized.

/// USB device drivers

Connect the IKA device through the USB data cable to the PC. The data communication is via a virtual COM port.

From Windows 10 and onwards the standard Windows USB driver is automatically loaded and a COM port number is assigned (find details in Windows Device Manager: "USB Serial Port (COMxx)"). If you have problems with USB communication, first ask your IT system administrator whether access to the USB interface is restricted for data security reasons.

/// Command syntax and format:

The following applies to the command set:

- › Commands are generally sent from the computer to the device.
- › The device sends only at the computer's request. Even fault indications cannot be sent spontaneously from the device to the computer (automation system).
- › Commands are transmitted in capital letters.
- › Commands and parameters including successive parameters are separated by at least one space (Code: hex 0x20).
- › Each individual command (incl. parameters and data) and each response are terminated with CR LF (Code: hex 0x0d hex 0x0A) and have a maximum length of 80 characters.
- › The decimal separator in a number is a dot (Code: hex 0x2E).

The above details correspond as far as possible to the recommendations of the NAMUR working party (NAMUR recommendations for the design of electrical plug connections for analogue and digital signal transmission on individual items of laboratory control equipment, rev. 1.1).

The NAMUR commands and the additional specific IKA commands serve only as low level commands for communication between the device and the PC. With a suitable terminal or communications programme these commands can be transmitted directly to the device. The IKA software package, Labworldsoft®, provides a convenient tool for controlling the device and collecting data under MS Windows, and includes graphical entry features, for motor speed ramps for example.

Commands	Function
IN_PV_2	Read the actual temperature.
IN_SP_2	Read the setting temperature.
IN_SP_3	Read the safety setting temperature.
IN_SP_4	Read the fan speed.
IN_PV_60	Read the actual shaking speed (rpm).
IN_SP_60	Read the set shaking speed (rpm).
OUT_SP_2 X (X=5 ... 80)	Set the target temperature.
OUT_SP_4 X (X=40 ... 100)	Set the fan speed, in steps of 10%.
OUT_SP_60 X (X=10 ... 300)	Set the shaking speed (rpm).
OUT_SP_12@n	Setting WD safety limit temperature with set value echo.
OUT_SP_42@n	Setting WD safety limit speed with set value echo.
OUT_WD1@m	Watchdog mode 1: if event WD1 should occur, the tempering functions are switched off and PC1 is displayed. Set watchdog time to m (20 - 1,500) seconds, with watchdog time echo. This command launches the watchdog function and must be transmitted within the set watchdog time.
OUT_WD2@m	Watchdog mode 2: if event WD2 should occur, the temperature target value is changed to the WD safety temperature limit value. The warning PC2 is displayed. The WD2 event can be reset with OUT_WD2@0 - this also stops the watchdog function. Set watchdog time to m (20 - 1,500) seconds, with watchdog time echo. This command launches the watchdog function and must be transmitted within the set watchdog time.
START_2	Start the tempering function.
STOP_2	Stop the tempering function.

Commands	Function
START_60	Start the shaking function.
STOP_60	Stop the shaking function.
RESET	Switch off the device function.

Note: when disconnecting the USB cable while the device is running, the device stays in PC mode. To reset to function without PC, switch the device off and on again.

“Watchdog” function, monitoring the serial data flow:

The following applies to situations where the watchdog function is enabled (see Namur instructions). If no new transmissions of these commands from the PC take place within the preset watchdog time, the tempering function will be shutdown according to the watchdog mode selected or will be controlled using the preset setpoints. An operating system crash, a PC power failure or a fault in the connecting cable to the device can cause an interruption in data transmission.

“Watchdog”– Mode 1

If an interruption in data transmission occurs which is longer than the preset watchdog time, the tempering function will be shutdown and the error message PC 1 will be displayed.

“Watchdog”– Mode 2

If an interruption in data transmission occurs which is longer than the preset watchdog time, the temperature setpoint will be set to the WD safety temperature setpoint. The PC 2 warning message will be displayed.

/// Connections between device and external devices:

USB 2.0 cable (A - C):

This cable is required to connect USB interface to a PC.



/// Device software update

Keep your device up-to-date with the IKA Firmware update tool.

The firmware update can be done with a computer connected through USB-Interface.

For this, you need register on our website MyIKA first.

After registering your device IKA will inform you about available updates for your devices. Please download the software "FWUToolSetup.zip" from our IKA service website.

Error codes

Any malfunctions during operation will be identified by an error message on the display.

Proceed as follows in such cases:

- › Switch off the device with the power switch or disconnect the device from the power supply.
- › Carry out corrective measures.
- › Restart the device.

i In case of a failure, press the control knob or start/stop button for 1 seconds to show the full error code.

Error code | Causes | Effect | Solutions

E10040902	
Causes	› Compressor discharge temperature fault.
Effect	› Tempering function off › Shaking function off
Solutions	› Check operating conditions according to the "Technical data". › Wait until over-temperatures / -pressures are equilibrated. › Clean the filter.
E10042702	
Causes	› Safety shutdown of the compressor.
Effect	› Tempering function off › Shaking function off
Solutions	› Check operating conditions according to the "Technical data". › Wait until over-temperatures / -pressures are equilibrated. › Restart the device.
E10043703	
Causes	› Compressor suction temperature fault.
Effect	› Tempering function off › Shaking function off
Solutions	› Check operating conditions according to the "Technical data". › Wait until over-temperatures / -pressures are equilibrated. › Restart the device.
E10144420	
Causes	› Heater error
Effect	› Tempering function off › Shaking function off
Solutions	› Contact IKA service department.
E10240702	
Causes	› Shaking platform overloaded.
Effect	› Tempering function off › Shaking function off
Solutions	› Reduce shaking load and power off the device for 40 secs. › Contact IKA Services.

E10322713 / E10332713	
Causes	› Safety relay does not open
Effect	› Tempering function off › Shaking function off
Solutions	› Contact IKA service department.

E10330611	
Causes	› Temperature exceeds the limit value of the safety switch. › Safety switch damaged.
Effect	› Tempering function off › Shaking function off
Solutions	› Contact IKA service department.

E10353605	
Causes	› Shaking speed not reached.
Effect	› Tempering function off › Shaking function off
Solutions	› Reduce shaking load and power off the device for 40 secs. › Contact IKA Services.

E10393524	
Causes	› Set temperature limit exceeded
Effect	› Tempering function off › Shaking function off
Solutions	› Switch off the device and let it cool down. › Contact IKA service department.

E10412324	
Causes	› Temperature inside device (PCB power) too high
Effect	› Tempering function off › Shaking function off
Solutions	› Switch off device and allow it to cool down.

E10412923	
Causes	› No internal sensor
Effect	› Tempering function off › Shaking function off
Solutions	› Contact IKA service department.

If the action described fails to resolve the fault or another error code is displayed then take one of the following steps:

- › Contact the service department.
- › Send the device for repair, including a short description of the fault.

Maintenance and cleaning

The device is maintenance-free. It is only subject to the natural wear and tear of components and their statistical failure rate.

/// Cleaning

For cleaning disconnect the mains plug!

Use only cleaning agents which have been approved by IKA to clean the devices:

These are: water (containing surfactant) and isopropyl alcohol.

- › Wear protective gloves during cleaning the devices.
- › Electrical devices may not be placed in the cleansing agent for the purpose of cleaning.
- › Do not allow moisture to get into the device when cleaning.
- › Before using another than the recommended method for cleaning or decontamination, the user must ascertain with that this method does not destroy the device.

⚠ Notice!

Clean the device interior after each use in order to prevent potential corrosion damage by the ingredients of the loading material.

Prior to reuse the device, allow the device interior to dry completely after cleaning.

Interior and metal surfaces:

Clean the metal surfaces of the device with normal stainless steel cleaning agents.

Make sure that no rusty objects come into contact with the device or with the metal housing. Rust deposits lead to an infection of the stainless steel.

If rust spots appear on the surface of the device due to impurities, immediately clean and polish the affected area.

Plastic parts:

Do not clean the operating panel and other plastic parts of the chamber with abrasive or solvent-based cleaning agents.

Glass surface:

Clean the glass surface with commercial glass cleaning agent.

Dust filter:

To keep the full cooling performance, the dust filter of the device must be checked regularly and cleaned if necessary.

- › Switch off the device and disconnect power cable.
- › Take out the dust filter.
- › Clean the dust filter with a vacuum cleaner or wash the sheet in the water. Dry the filter before reassembly.

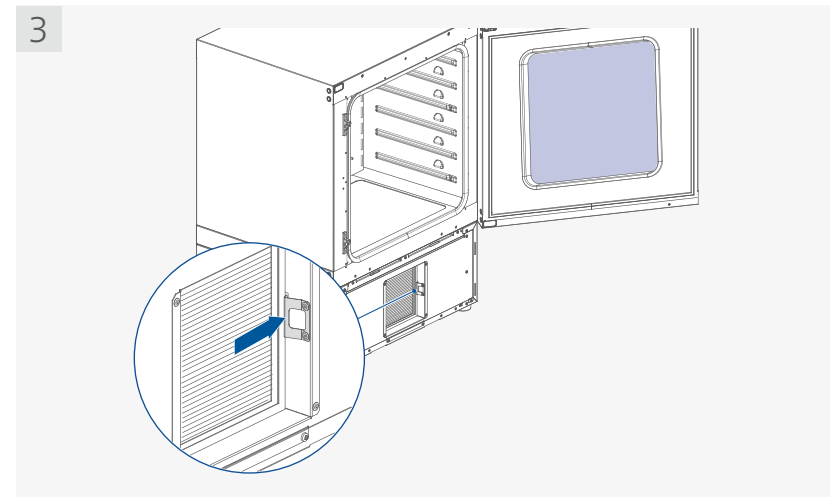
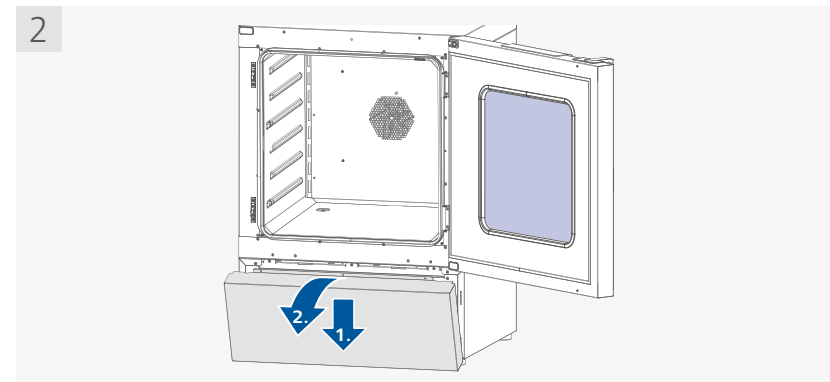
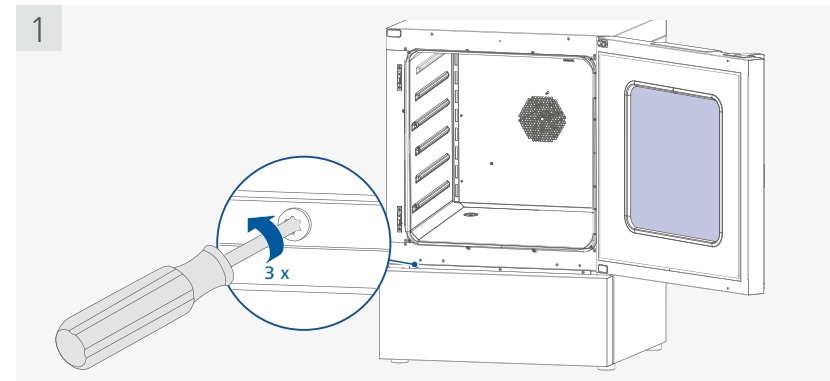

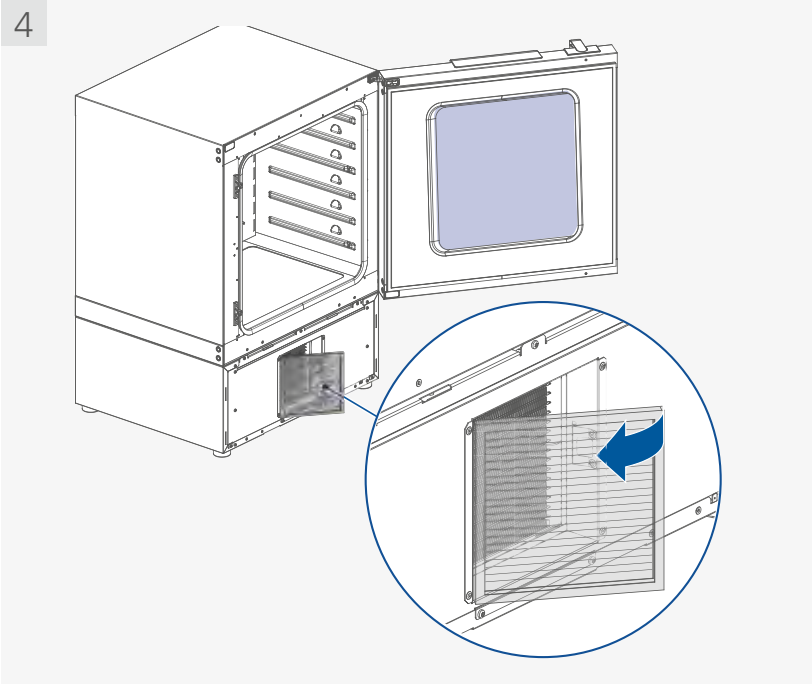

Condenser:

To keep the full cooling performance, check and clean the condenser with a vacuum cleaner or a brush regularly.

Note: Don't touch the condenser surface with hard parts.

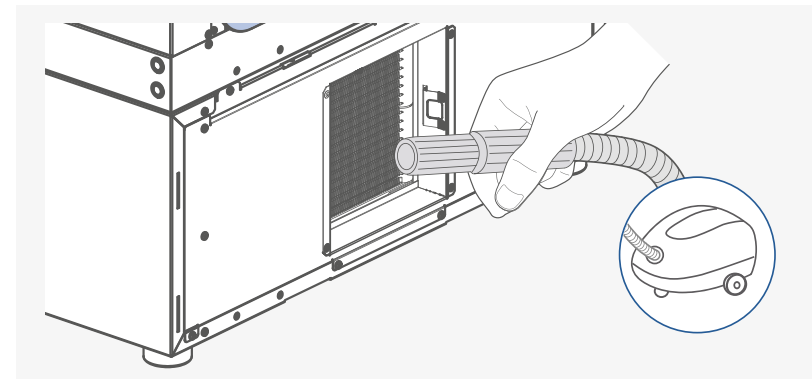

/// Decontamination

The device allows 2.5-hour hot air decontamination at 100 °C. For details, see the "Decontamination" menu in the "Menu details" section.

Note: Before decontamination, the device must be completely emptied.

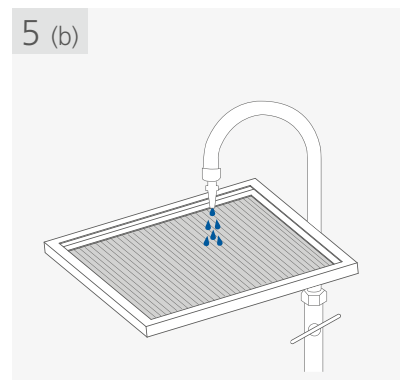
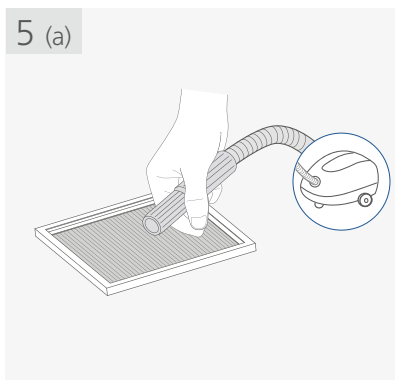

/// Ordering spare parts

When ordering spare parts, please indicate:

- > Device type.
- > Serial number, see type plate
- > Item and designation of the spare part, spare parts diagram and spare parts list.
- > Software version (Briefly visible in the display when the device is switched on).

/// Repairs

Please send in device for repair only after it has been cleaned and is free from any materials which may constitute a health hazard.

For repair, please request the "Decontamination Certificate" from **IKA**, or download printout of it from the **IKA** website.

If you require servicing, return the device in its original packaging. Storage packaging is not sufficient. Please also use suitable transport packaging.

Shaking platform

The following shaking platform are offered as accessories:

SP 20 Shaking platform

SP 25 Shaking platform

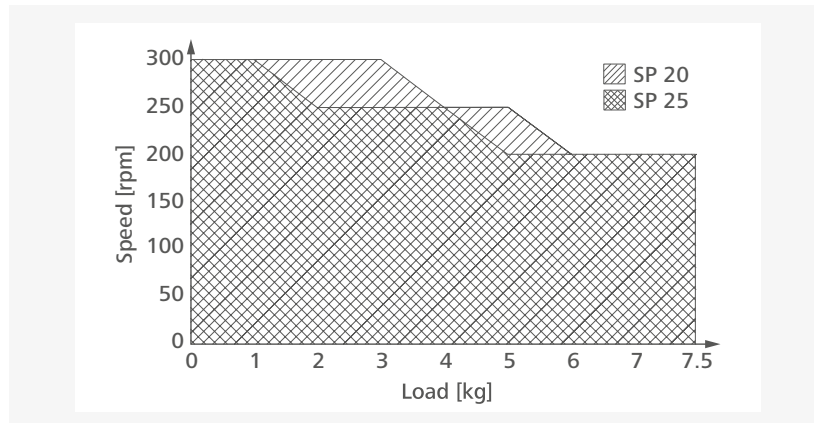

In order to ensure safe and secure operation, the shaking platform must only be operated within the range of usable weight and speed (see diagram - hatched area).

If you notice that the device is running unevenly, the speed must in any case be reduced until the running irregularities no longer occur.

Make certain that individual vessels are placed in the middle of the shaking platform and multiple shaking vessels are placed evenly on the shaking platform, and that all vessels are securely fastened in place.

Max. permissible shaking vessels:

Erlenmeyer flask size	With fixing clip	With STICKMAX
10 ml	96 pcs	128 pcs
25 ml	39 pcs	111 pcs
50ml	39 pcs	66 pcs
100ml	24 pcs	36 pcs
200 ml / 250 ml	12 pcs	20 pcs
500 ml	12 pcs	12 pcs
1000 ml	6 pcs	8 pcs
2000 ml	2 pcs	6 pcs

Accessories

IO T 1.00

Wire grid tray

IO T 1.10

Enhanced wire grid tray

IO T 2.10

Wire grid tray

IO T 2.20

Perforated tray

IO T 2.30

Drip pan

IO SP 25

Shaking platform

IO SP 20

Shaking platform

IO S 2.10

Stacking kit

IO F 1.10

Roller frame

IO B 1.10

Roller box

IO P 1.10

Table top work plate

AS 2.0

Fixing clip, 10 ml

AS 2.1

Fixing clip, 25 ml

AS 2.2

Fixing clip, 50 ml

AS 2.3

Fixing clip, 100 ml

AS 2.4

Fixing clip, 200 / 250 ml

AS 2.5

Fixing clip, 500 ml

AS 2.6

Fixing clip, 1000 ml

AS 2.7

Fixing clip, 2000 ml

STICKMAX

See more accessories on www.imlab.eu.



Technical data

Operating voltage	VAC	230 ± 10 % / 115 ± 10 % / 100 ± 10 %
Frequency	Hz	50 / 60
Max. input power	W	1000
Heating power	W	750 (115 / 230 V) / 560 (100 V)
Refrigerant		R 290
Refrigerant quantity	g	55
Max. refrigerating system pressure	bar	21
Fuse		2 x T6.3 A (230V) / 2 x T10A (100 / 115V)
Working temperature range	°C	+ 5 ... + 80
Thermal safety device according to DIN 12880		TB class 1
Setpoint limiter with safety shutdown		Yes
Temperature setting resolution	K	0.1
Temperature stability (at 37°C)	K	± 0.2
Temperature homogeneity (at 37°C)	K	± 0.3
Temperature heating up time (from RT: 22°C to 37°C)	min	8
Temperature recovery time (from 37°C to RT: 22°C, open door 30 seconds)	min	4
Temperature display		LCD
Shaking function		Yes
Shaking stroke: with SP 20 shaking platform	mm	20
with SP 25 shaking platform	mm	25
Shaking speed range	rpm	10 ... 300
Speed deviation	rpm	± 5
Permissible shaking weight (include attachment)	kg	7.5
Timer/counter function		Yes
Timer/counter display		LCD
Max. timer/counter		100 days (99:23:59 [d:h:min])
Max. number of tray		6
Max. load for one tray	kg	20
Chamber volume	l	125
Inside dimensions (W x H x D)	mm	550 x 550 x 415
Drain tube inner diameter	mm	10
Noise level	dB(A)	55
Power consumption at 37°C	Wh/h	79
Interface		USB
Permissible ambient temperature	°C	+ 15 ... + 32
Permissible relative humidity	%	70
Permitted on-time	%	100
IP code according to EN 60 529		IP 20
Protection class		I

Overvoltage category		II
Contamination level		2
Dimensions (W x H x D)	mm	700 x 1000 x 635 (+70 with hand grip)
Weight	kg	95
Operation at a terrestrial altitude	m	max. 2000

Note:

- > Refrigerant must be disposed of in accordance with local and national regulations.
- > The device complies to: DIN 12880: 2007 und JfF 1101-2019 (up to 80 °C).
Technical data for unloaded devices, at ambient temperature 22 °C ± 2 K.

Subject to technical changes!

Warranty

In accordance with IKA terms of sale and delivery, the warranty period is 24 months. For claims under the warranty please contact your local dealer. You may also send the machine direct to our factory, enclosing the delivery invoice and giving reasons for the claim. You will be liable for freight costs.

The warranty does not cover worn out parts, nor does it apply to faults resulting from improper use, insufficient care or maintenance not carried out in accordance with the instructions in this operating manual.

Dimensions

