

# IKA

designed for scientists

## MATRIX DELTA PLUS

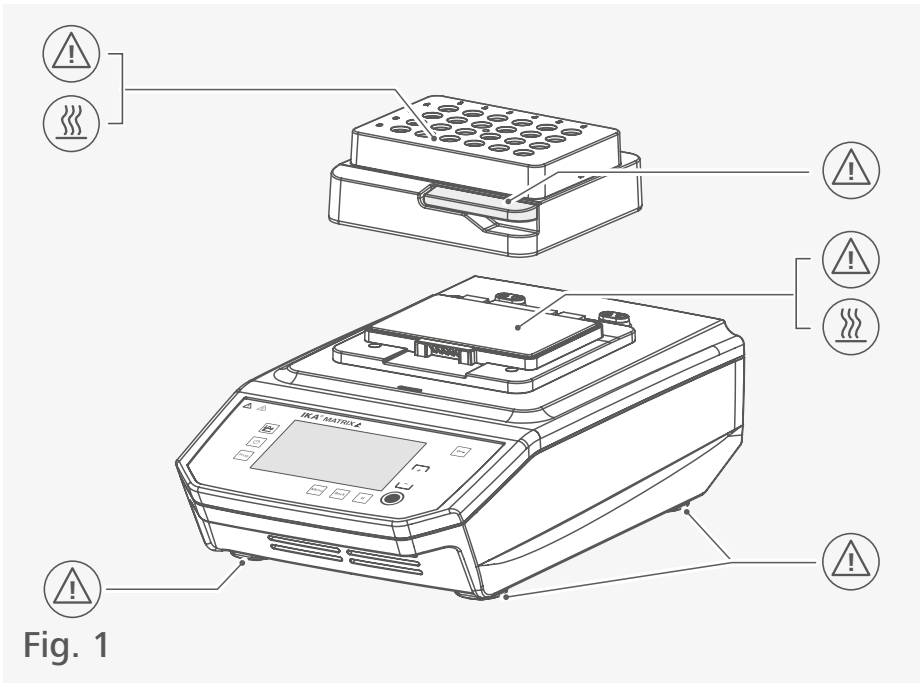

Fig. 1

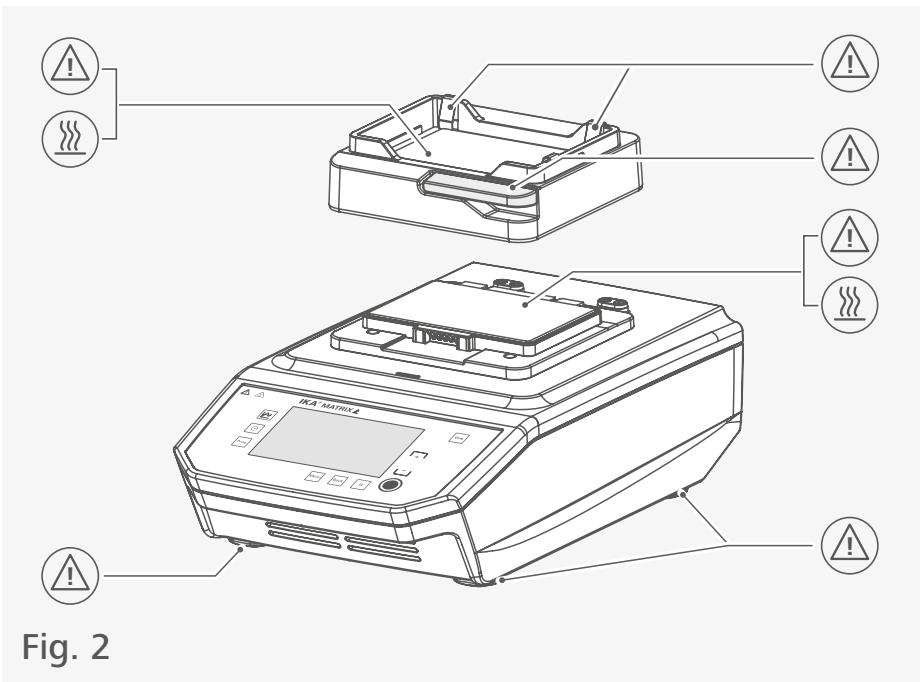











Fig. 2

	EU Declaration of conformity .....	6
	Explication of warning symbols .....	6
	Safety instructions.....	7
	Intended use.....	9
	Unpacking .....	10
	Operator panel and display .....	11
	Installation.....	13
	Operation .....	17
	Menu navigation and structure .....	23
	Interfaces and outputs .....	29
	Error codes .....	33
	Maintenance and cleaning .....	34
	Accessories .....	35
	Technical Data .....	36
	Warranty .....	37



## EU Declaration of conformity

We declare under our sole responsibility that this product corresponds to the directives 2014/35/EU, 2006/42/EC, 2014/30/EU and 2011/65/EU and conforms with the following standards or normative documents: EN 61010-1, EN 61010-2-010, EN 61326-1, EN 60529 and EN ISO 12100.

A copy of the complete declaration of conformity or further declarations of conformity can be requested.



## Explication of warning symbols

### /// Warning symbols

- Danger!** Indicates an (extremely) hazardous situation, which, if not avoided, will result in death, serious injury.
- Warning!** Indicates a hazardous situation, which, if not avoided, can result in death, serious injury.
- Caution!** Indicates a potentially hazardous situation, which, if not avoided, can result in injury.
- Notice!** Indicates practices which, if not avoided, can result in equipment damage.
- Caution!** Indicates a hazardous situation that cause from a hot surface!
- Caution!** Indicates crushing risk to fingers / hands.

### /// General Symbols

**A** — Position number

- Correct / Result!**  
Shows the correct execution or the result of an action step.
- Wrong!**  
Shows the incorrect execution of an action step.
- Note!**  
Displays action steps that require particular attention to detail.
- Closed lock!**  
Indicates the status of "locked".
- Open lock!**  
Indicates the status of "Unlocked".

## Safety instructions

### /// General information

- > **Read the operating instructions completely before starting up and follow the safety instructions.**
- > Keep the operating instructions in a place where it can be accessed by everyone.
- > Ensure that only trained staff work with the device.
- > Follow the safety instructions, guidelines, occupational health and safety and accident prevention regulations.
- > The device must only be used in a technically perfect condition.

#### **Caution!**

- > Wear your personal protective equipment in accordance with the hazard category of the medium to be processed, there is a risk of:
  - splashing of liquids
  - release of toxic or combustible gases
  - body parts, hair, clothing and jewellery getting caught.

#### **Notice!**

- > Pay attention to the marked sites in Fig. 1 and Fig. 2.

### /// Device setup

#### **Caution!**

- > The power switch of the device must be accessed immediately, directly and without risk at any time. If access to the power switch cannot be ensured, an additional emergency stop switch that can be easily accessed must be installed in the work area.
- > Ensure that your hands / fingers do not get crushed when setting down the device.

#### **Notice!**

- > Set up the device in a spacious area on an even, stable, clean, non-slip, dry and fireproof surface.
- > Make sure that the ventilation slots are not blocked at back of the device.
- > Observe the minimum distances:
  - between devices min. 100 mm
  - between device and wall min. 100 mm.

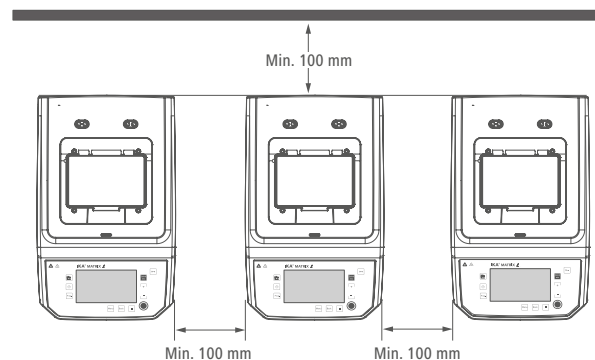

### /// Working with the device

#### **Danger!**

- › Do not use the device in explosive atmospheres, it is not EX-protected.
- › With substances capable of forming an explosive mixture, appropriate safety measures must be applied, e.g. working under a fume hood.
- › To avoid body injury and property damage, observe the relevant safety and accident prevention measures when processing hazardous materials.

#### **Warning!**

- › Only process samples that will not react dangerously to the extra energy produced through processing. This also applies to any extra energy produced in other ways, e.g. through light irradiation.
- › Only media whose flash point lies above 170 °C can be heated with this device (according to EN 61010-2-010).
- › When handling hazardous substances or mixtures of substances which are toxic or are contaminated with pathogenic micro-organisms, the user should take appropriate precautions. Observe the national regulations, the biosafety level of your laboratory, the material safety data sheets.
- › For germs or biological material or risk group II or higher, please observe the "Laboratory Biosafety Manual" issued by the World Health Organisation).

#### **Caution!**

- › Please pay attention to avoiding hand injury when operate the device.
- › The heating plate and the attachments can be very hot and cause injuries. Be careful when touching the attachments.
- › Pay attention to the residual heat after switching off the device.
- › Allow the attachments to cool down completely before removing them.

#### **Notice!**

- › The device must be operated on flat surface and must not be moved during operation.
- › Covers or parts that can be removed from the device without tools must later be refitted to ensure safe operation. This will prevent the infiltration of foreign objects, liquids and other contaminants.
- › Never use tubes made of glass or other fragile material. Glass tubes can be smash.
- › Only use sealed micro test tube and sealed microplate / deepwell plate.
- › The micro test tube / microplate / deepwell plate must always be closed during operation. Switch off the device immediately if any material leaks from the vessel. Clean the device after disconnected power plug.
- › The feet of the device must be clean and undamaged.

### /// Accessories

- › Protect the device and accessories from bumping and impacting.
- › Check the device and accessories beforehand for damage each time when you use them. Do not use damaged components.
- › Safe operation is only guaranteed with the accessories described in the "Accessories" section.

### /// Power supply / switching off the device

- › The voltage stated on the type plate must correspond to the power voltage.
- › The device can only be disconnected from the power supply by pulling out the power plug or the connector plug.
- › The device must only be operated with the original power cord set.
- › The socket for the power cord must be easily accessible.
- › Socket must be earthed (protective ground contact).
- › The device will automatically restart in mode B and C following any interruption to the power supply.

### /// Maintenance

- › The device must only be opened by trained specialists, even during repair. The device must be unplugged from the power supply before opening. Live parts inside the device may still be live for some time after unplugging from the power supply.
- › Only use original IKA spare parts!

### /// Disposal instructions

- › The device, accessories and packaging must be disposed of in accordance with local and national regulations.

## Intended use

### /// Use

The **MATRIX DELTA PLUS** device is used for tempering liquids in closed tubes and closed plates in the preparation of samples.

**Intended use:** Tabletop device

### /// Range of use

Indoor environments similar to that of a laboratory in research, education, commerce or industry.

The safety of the user cannot be guaranteed:

- › if the device is operated with accessories that are not supplied or recommended by the manufacturer.
- › if the device is operated improperly or contrary to the manufacture's specifications.
- › if the device or the printed circuit board are modified by third parties.





## Unpacking

- › Please unpack the device carefully.
- › Any damage should be notified immediately to the shipping agent (post office, railway network or logistics company).

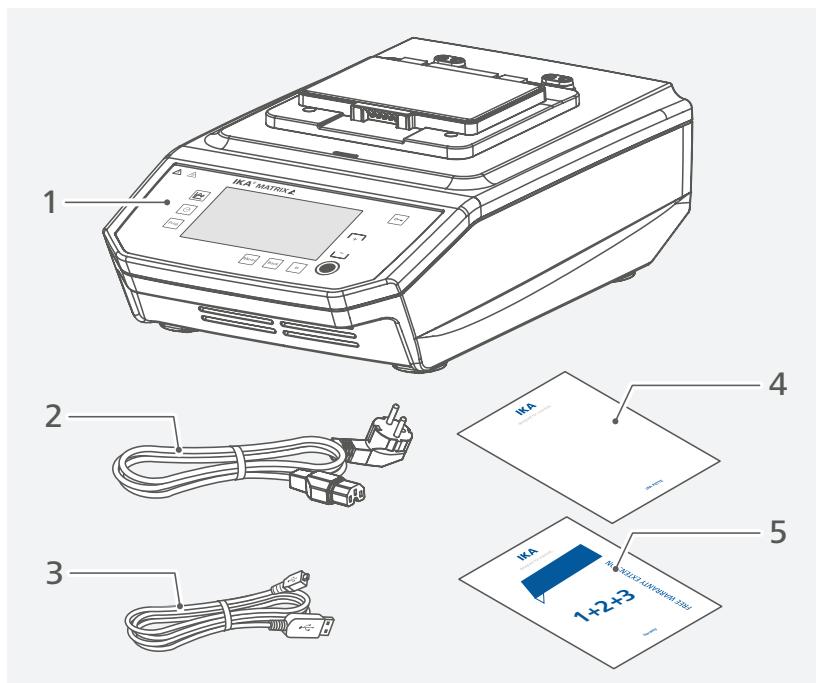

1	<b>MATRIX DELTA PLUS</b>
2	Power cable
3	USB cable

4	User guide
5	Warranty card

## Operator panel and display

/// Explanation of the control elements

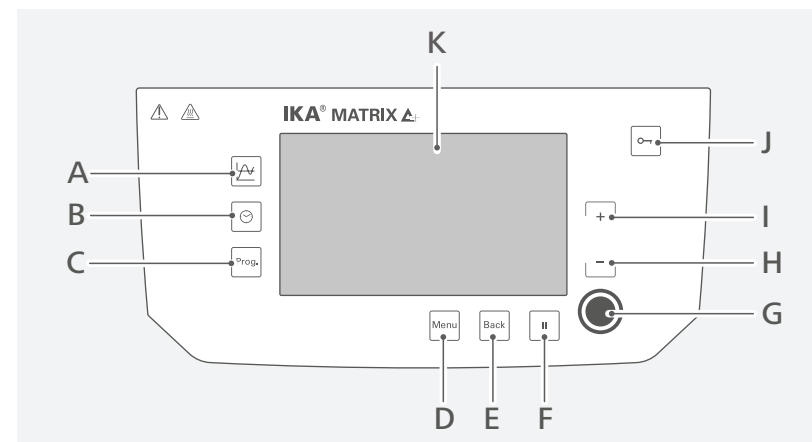

Item	Designation	Function
A	Graph button	Enter the graph (Time / Temperature) menu.
B	Timer button	Enter the timer menu.
C	"Programs (Prog.)" button	Enter the programs menu.
D	"Menu" button	Touch it once: main menu is displayed. Touch it a second time: back to the working screen.
E	"Back" button	Return to the previous menu level.
F	Pause (  ) button	Touch it once: Pause the tempering function. Touch it a second time: Restart the tempering function.
G	Tempering button	Start / stop the tempering function. Confirm the select menu option in menu / sub-menu.
H	Temperature (-) button	Decrease the temperature setting. Menu navigation in menu / sub-menu.
I	Temperature (+) button	Increase the temperature setting. Menu navigation in menu / sub-menu.
J	Lock button	Lock / unlock the buttons.
K	Display	Screen.

### /// Explanation of symbols on the working screen

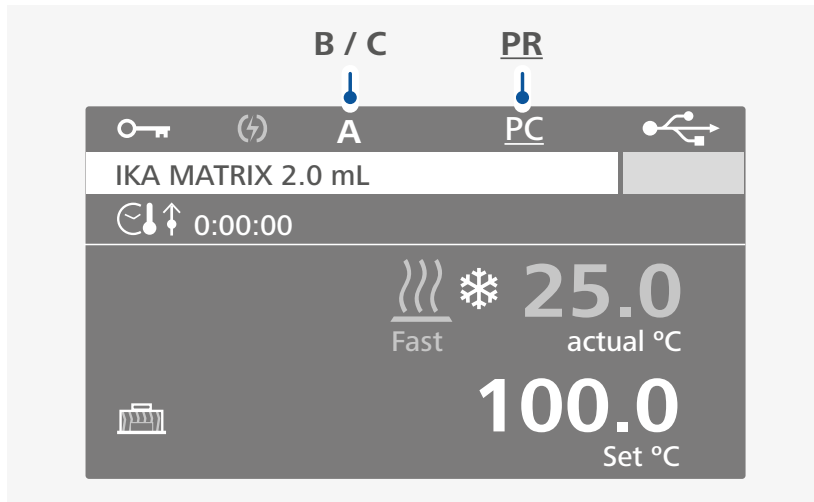

Symbol	Designation	Function
	Lock button symbol	Indicate the buttons are locked.
<b>A (B / C)</b>	Operating mode symbol	Indicate the device is in operating mode (A, B or C).
	USB connection symbol	Indicate the device is communicating via USB.
	Timer / Counter symbol (Tempering)	Indicate the "Timer / Counter" start condition is set to: "Immediately" (see "Tempering" under "Timer").
	Timer symbol (Tempering)	Indicate the "Timer" start condition is set to: "Set temperature reached" (see "Tempering" under "Timer").
	Counter symbol (Tempering)	Indicate the "Counter" start condition is set to: "Set temperature reached" (see "Tempering" under "Timer").
	Tempering (heating) symbol	Indicate the heating function is activated.
	Tempering (cooling) symbol	Indicate the cooling function is activated.
<b>Fast (Moderate / Slow)</b>	Temperatur control rate symbol	Indicate the tempering "Control rate" is set to "Fast (Moderate or Slow)".
<b>PC</b>	PC control symbol	Indicate the device is controlled by a PC.
<b>PR</b>	Program control symbol	Indicate the device is in program control mode.
	Power failure symbol	Indicate a previous power supply interruption.
	IKA ThermoCover Symbol	Indicate IKA ThermoCover is attached to the device.

**Note:** The symbols displayed change depending on the status and settings of the device.

## Installation

### /// Connection to the power supply

#### ⚠ Notice!

The socket used must be earthed (fitted with earth contact).  
Observe the ambient conditions (temperature, humidity etc.) listed under "Technical Data".

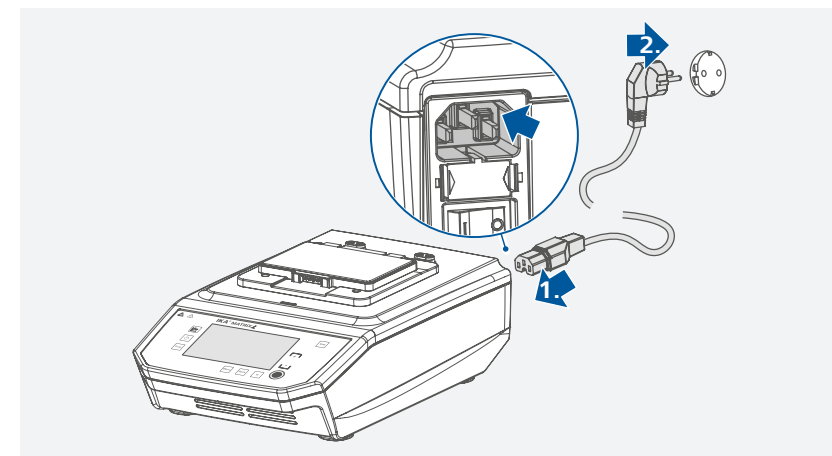
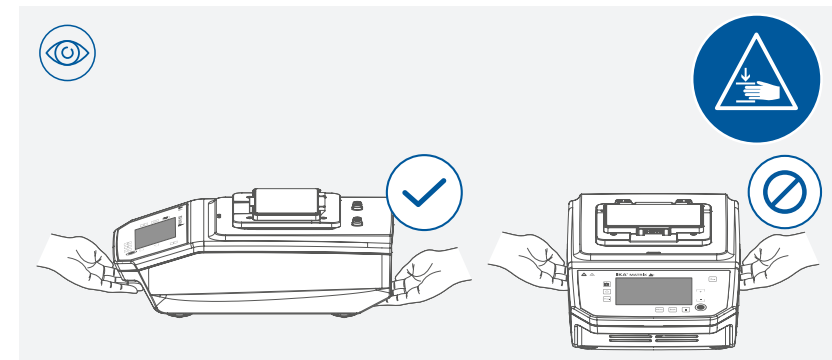
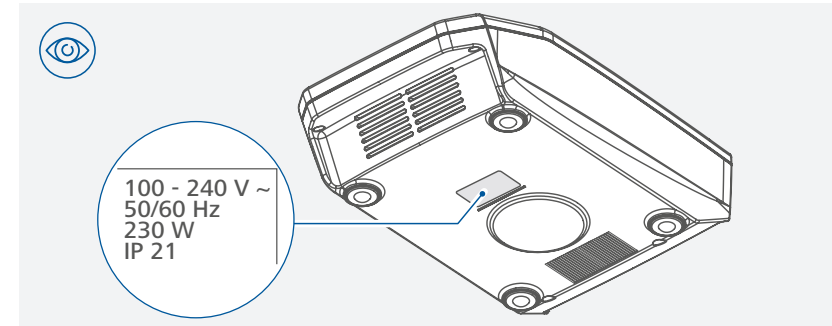

/// Attaching the exchangeable attachments

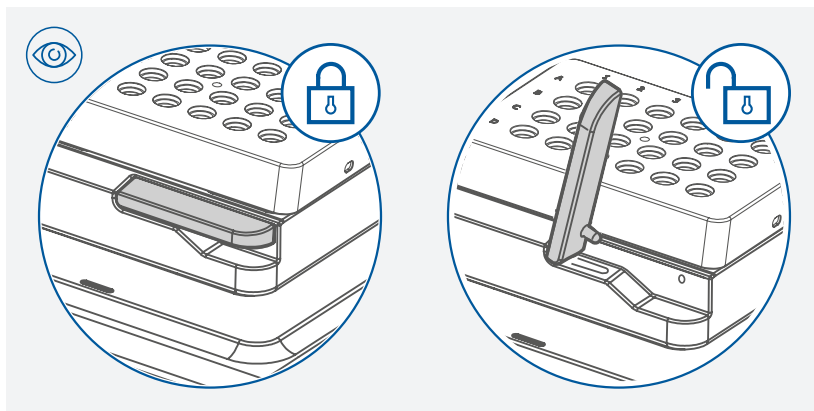
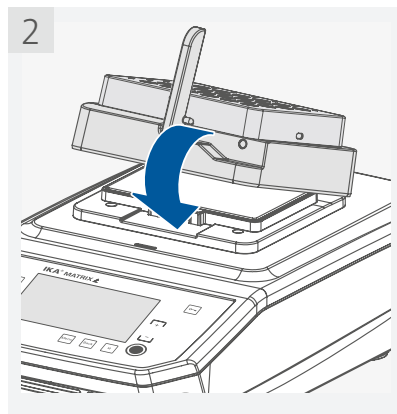
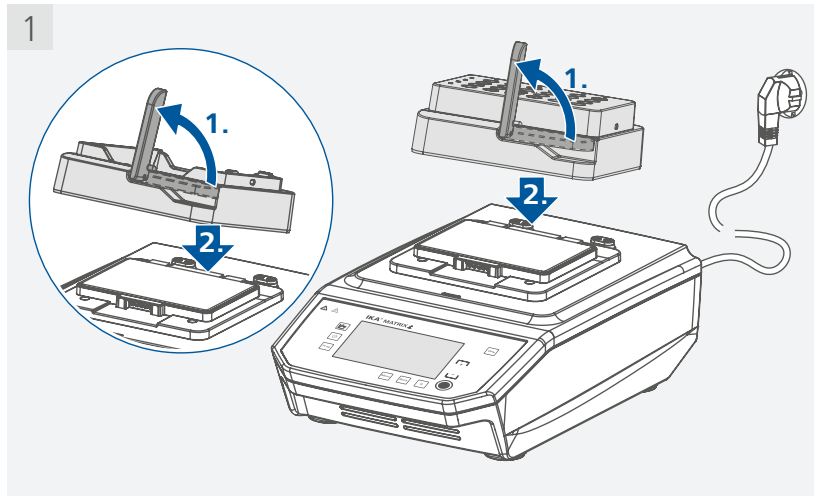

/// Inserting deepwell plate (DWP) / the microplate (MTP)

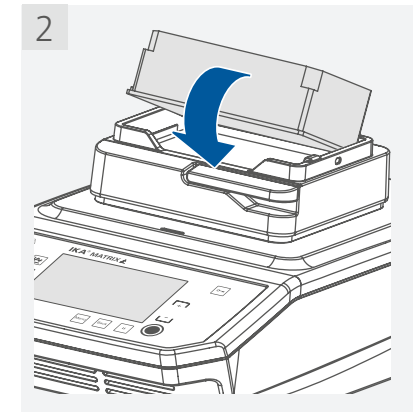
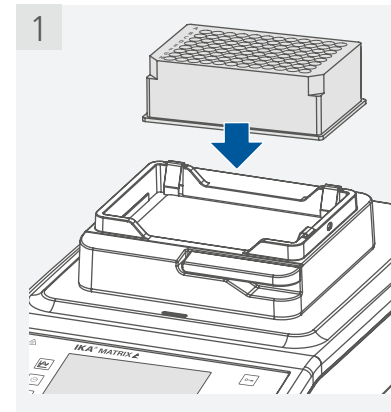

/// Inserting the micro test tubes

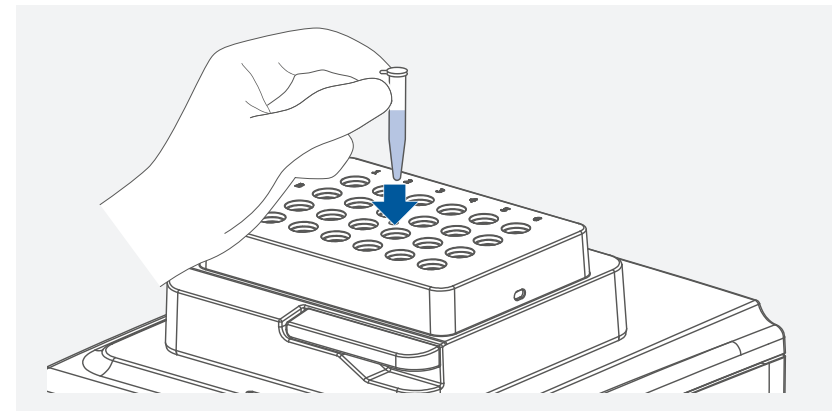

### /// Attaching the IKA Cover / IKA ThermoCover

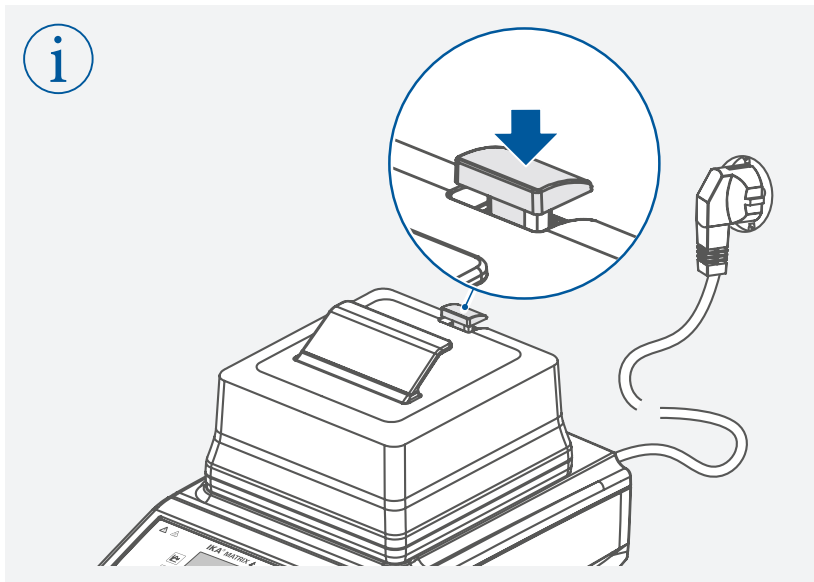
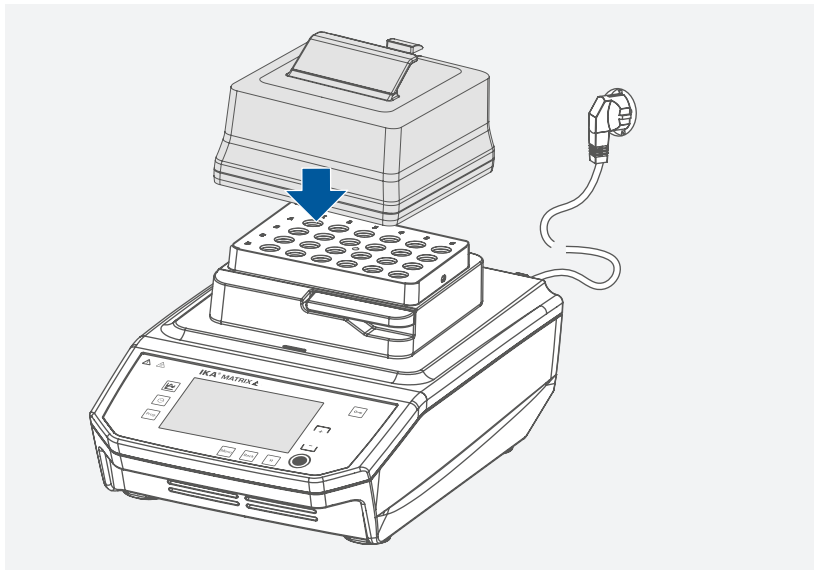

**Note:** After the contact of the ThermoCover cover has been established with the device by pressing down the button, the heating function can prevent the formation of condensate.

### Operation

#### /// Switching on

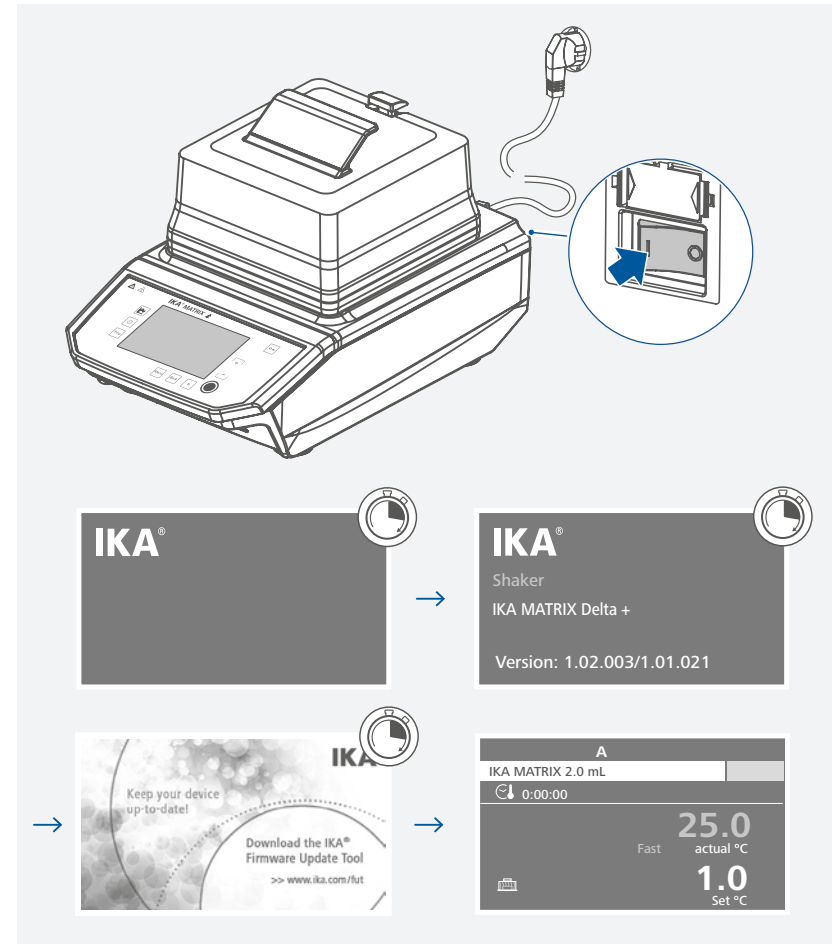

/// Setting the temperature and start tempering function

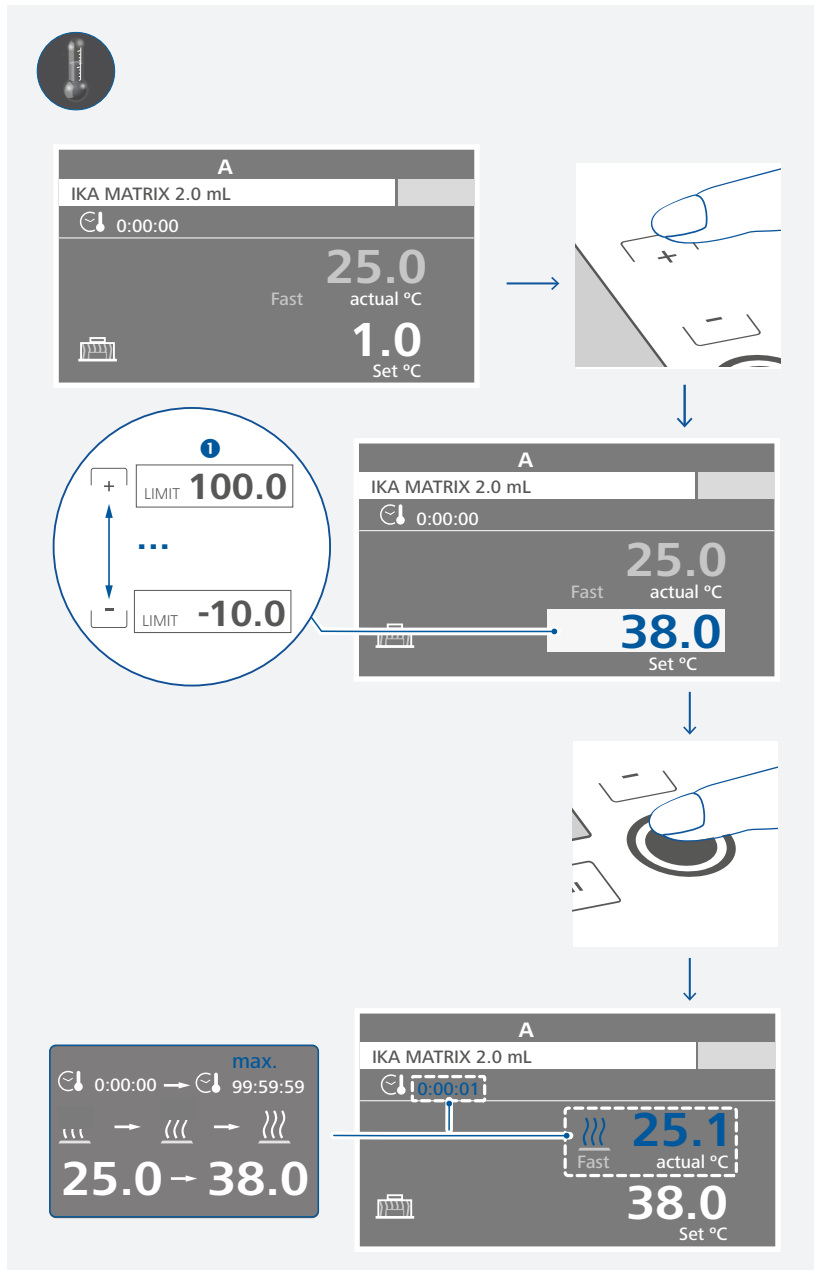

● **Note:** The maximum temperature limit value depends on attachments!

/// Pausing the tempering function

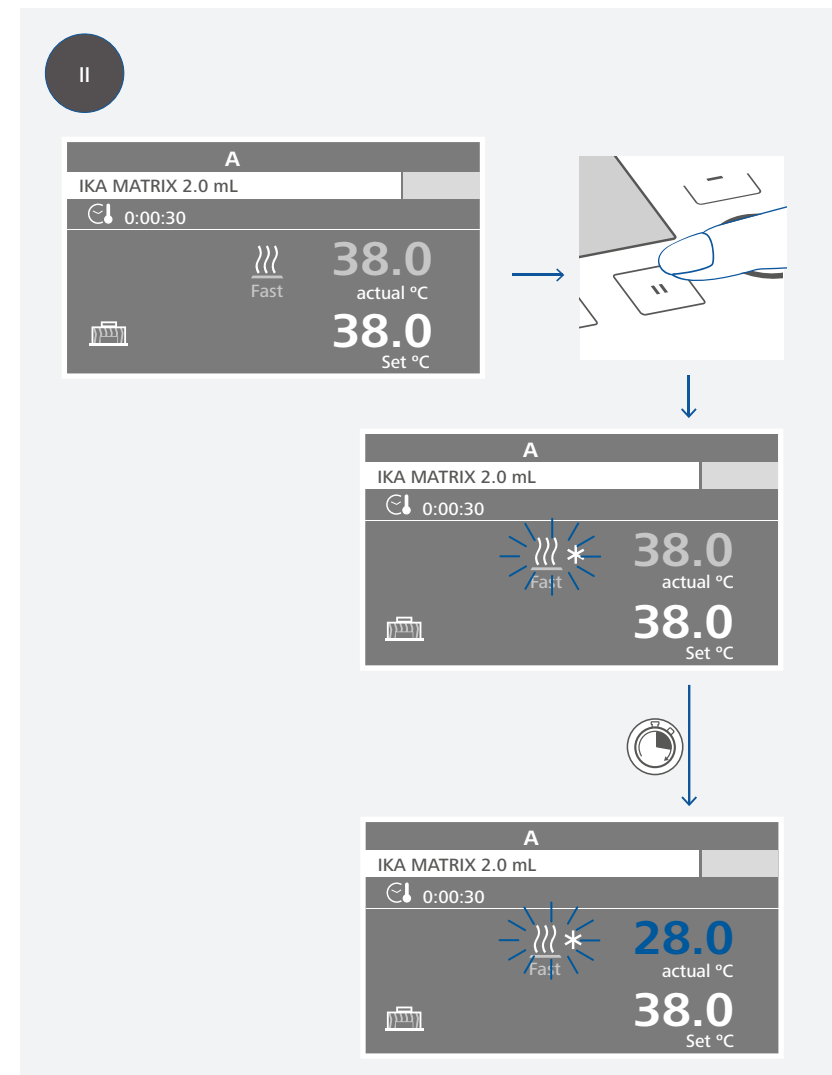

**Note:** During the pause status, the tempering function can be switched off by touching tempering button (G).

### /// Restarting the tempering function

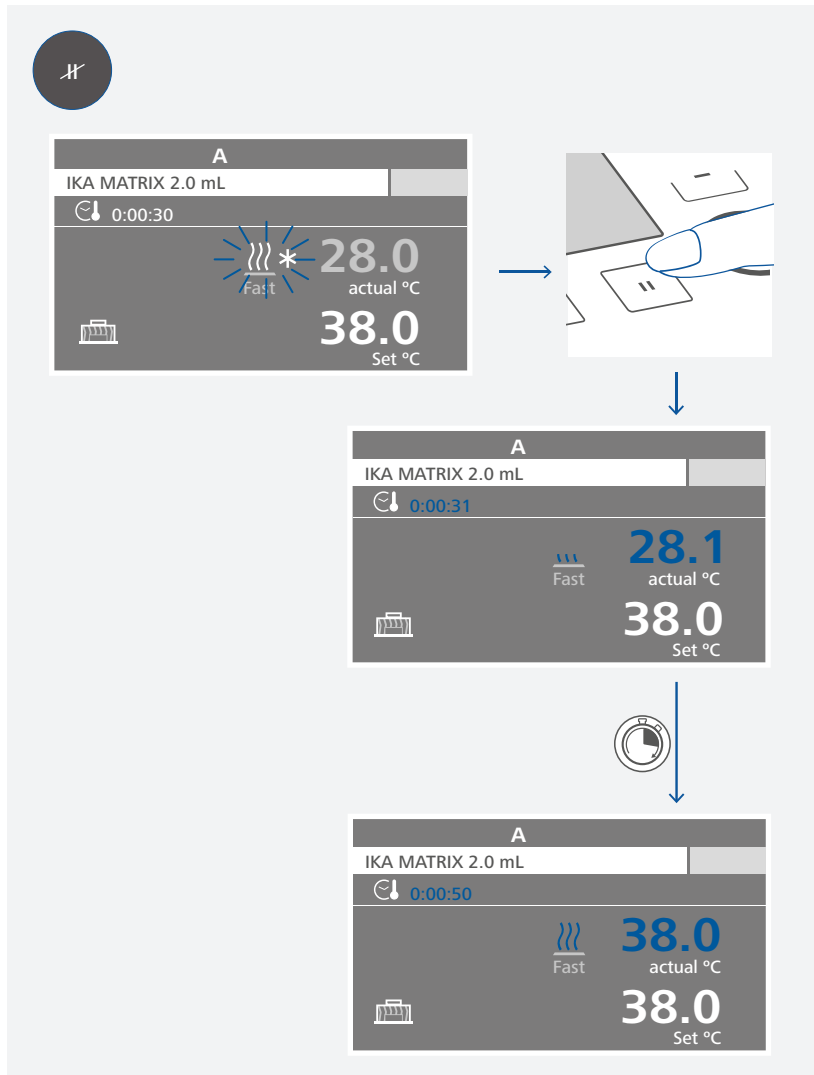

### /// Locking the buttons

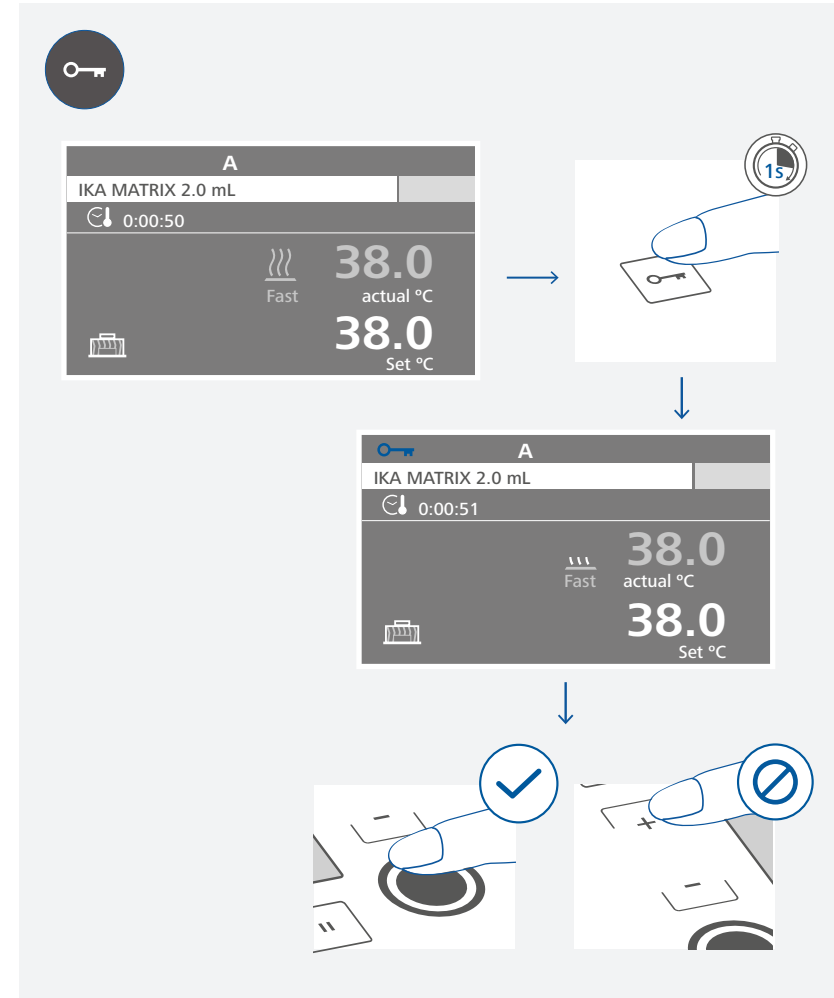

**Note:** When the buttons are locked, the tempering function still can be deactivated by touching the tempering button (G).

## /// Unlocking the buttons

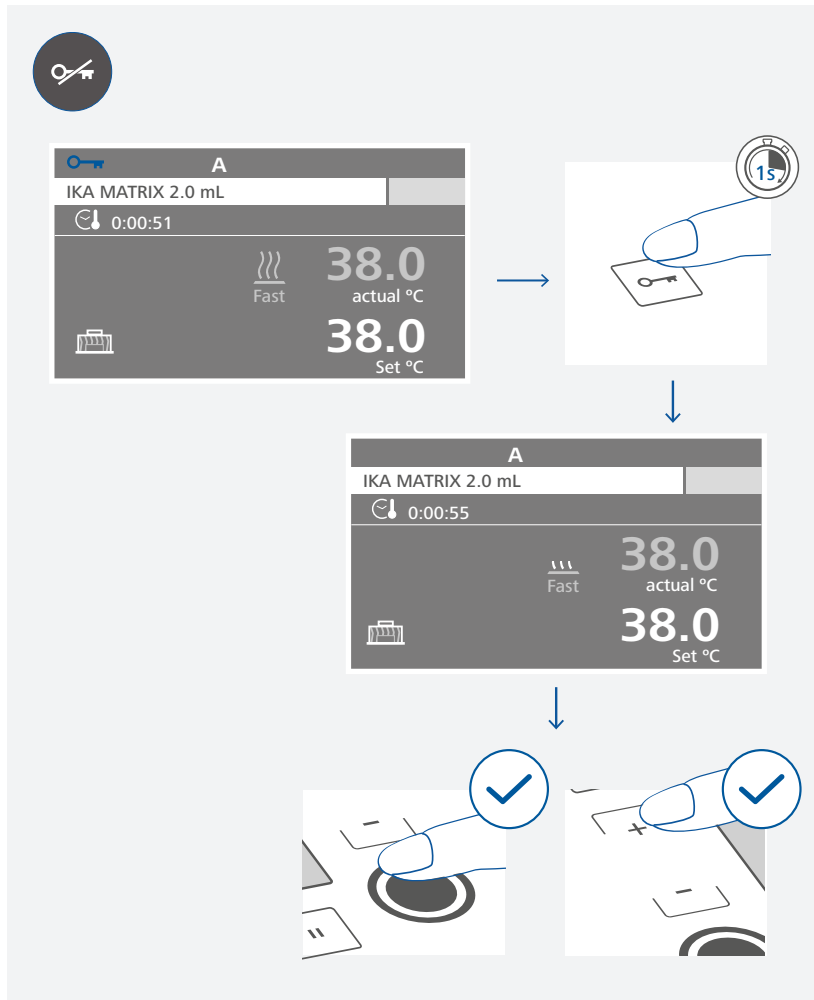

## Menu navigation and structure



### /// Menu navigation

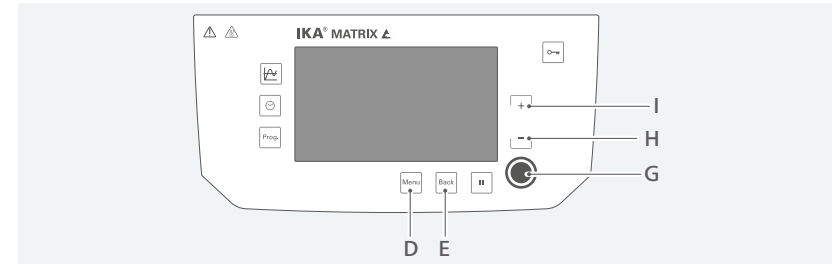

- > Press the "Menu" button (D).
- > Select the right menu item by touching the temperature (+) button (I).  
Select the left menu item by touching the temperature (-) button (H).
- > Confirm and enter selected menu item by touching the tempering button (G).
  - a) Select desired sub-menu by touching temperature (+) button (I) or temperature (-) button (H).  
Activate / deactivate a function by touching the tempering button (G).
  - b) Activate the editing function to a sub-menu by touching the tempering button (G).  
Edit the value by touching temperature (+) button (I) or temperature (-) button (H).  
Confirm the value by touching the tempering button (G).  
Save the new value either by touching the "Back" button (E) or by selecting "OK" with tempering button (G).

Note: the selected menu option is highlighted in blue on the screen and can be edited by touching (at the same time the color change to yellow) on the tempering button (G).

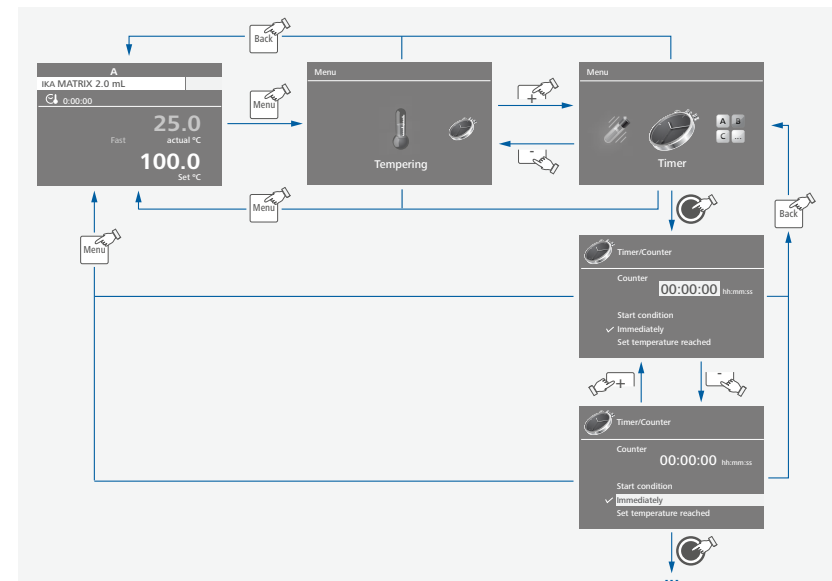

**Note:** When touching the "Menu" button (D), the system skips directly back to the working screen.  
When touching the "Back" button (E), the system skips back to the previous menu level screen.

### /// Menu structure

		Factory setting			
Menu	Tempering	Control rate			
		Fast	✓		
		Moderate			
		Slow			
	Timer	Timer / Counter	00:00:00 [hh:mm:ss]		
		Start Condition	Immediately	✓	
			Set Temperature Reached		
	Mode	A	✓		
		B			
		C			
	Graph	Axis scaling	X-Axis	5 minutes	
			Y-Axis		
			Automatic	✓	
			Manual	Maximum	110.0 °C
		Minimum		-10 °C	
		Program 1			
		Program 2			
		Program 5			
	Safety	Password	000		
	Settings	Languages	English	✓	
Deutsch					
Units		Temperature			
		°C	✓		
		°F			
Display		Background	Black	✓	
			White		
		Firmware Update Information	✓		
Sound		Key Tone	✓		
Factory Settings					
Information	Software				
	Version	1.02.003/1.01.021			
	Firmware Update Information	yes			

### /// Menu details

#### **Tempering:**

Control rate:  
In the "Control rate" menu option, you can select the desired control rate between "Fast", "Moderate" and "Slow". A check mark (✓) indicates the control rate is activated.

**Fast:** Fast tempering with a certain level overshooting.

**Moderate:** Moderate tempering with minimal overshooting.

**Slow:** Precise tempering without overshooting.

#### **Timer:**

In the "Timer" menu option, you can set "Timer / Counter" for "Tempering". You can set "Timer" value from 00:00:01 [hh:mm:ss] to 99:59:59 [hh:mm:ss]. The tempering function stops automatically after the set time has elapsed and the set time appears on the display.

**Note:** If the tempering function is stopped before the set timer value expires, the reverse counting of the timer is interrupted.

If you set the "Timer" value to 00:00:00 [hh:mm:ss], the counter is active. The counter automatically starts to run from 00:00:00 [hh:mm:ss] upto 99:59:59 [hh:mm:ss]. When the maximum value is reached, the device stops the tempering process.

In the menu option, you can set the timer / counter "Start condition" as:

Immediately: The timer / counter starts immediately when starting the tempering function.

Set temperature reached: The timer / counter starts only when the set temperature reached.

#### **Mode:**

Mode A:  
After power on / power failure no automatic restart of functions.

Mode B:  
After power on / power failure automatic restart of functions, depending on previous settings.

Mode C:  
Set values (set in mode A or B) cannot be changed. After power on / power failure automatic restart of functions, depending on previous settings.

## Graph:

### X - Axis:

In the "X - Axis" menu, you can set 5, 10, 20, 30, 60, 90 and 120 minutes as the scale for the X - Axis.

### Y - Axis:

In the "Y - Axis" menu, you can select "Automatic" or "Manual" axis scaling.

When you select "Automatic" axis scaling, a check mark (✓) indicates that the function is activated.

In "Automatic" axis scaling, Y-axis is scaled to maximum value.

When you select "Manual" axis scaling, you need set the maximum and minimum value for Y-Axis.

## Programs:

In the "Programs" menu option, you can create 5 user-defined "Temperature / Time" profiles. In addition, you can define the control mode (Time, Temperature hysteresis and Ramp) in the program.

A program can consist of up to 5 segments.

Once a program has been selected, the following options are available:

**Start:** Start the selected program upon request.

When you start the selected program, you are required to select "Infinite loop" or input "Loop count".

1. Infinite loop: Upon completion of the last segment, the program continues with the first segment until the user ends the program by stopping a device function.

2. Loop count: Indicates the total number of loop cycles until program end.

Press "OK" to start the program control. Confirm the following message if you want to start the program control, or press the "Menu" or "Back" button to end the process.

**Note:** At the end of the program all device functions (tempering function) are switched off.

**Edit:** Edit the selected program parameters.

Edit the selected program by pressing on the "Edit" with tempering button (G).

In the editing program, you can define up to 5 program segments. The selected program segment is highlighted in blue color.

Then, you can edit, delete, insert or save the selected program segment in this program.

When editing a parameter, press the tempering button on the selected parameter. The

highlighted cursor changed into yellow color indicates that parameter can be edited.

If the "Back" button is pressed after editing, a reminding appears and ask if you want to save the change. When you edit the program time for at least one segment, a symbol (⊞) for respective program will appear.

1. Seg No.: Segment number.

2. Temp.: Target temperature.

3. Ctrl. Mode: Control Mode.

In control mode "Time" the target values and settings of segment are valid for the duration indicated in the column "Time". Afterwards, the next program segment is automatically executed.

In control mode " $\pm x.x K$ ": The hysteresis (tolerance) of the actual temperature to target temperature is set (e.g.  $\pm 0.1 K$ ). The target values and settings of the segment are valid until the actual temperature reaches the target temperature  $\pm$  hysteresis for the first time. Afterwards, the next program segment is automatically executed.

Control mode "RAMP" is allowed to moderate evenly with a defined slope. The segment is closed after the target temperature has been reached.

The gradient in K/min comes from the quotient of the temperature difference and the time specified in the current segment.

The temperature difference is calculated from the target value temperatures of the current and preceding segment.

**Note:** The ramp function can only be selected from the second segment.

**Delete:** Deletes the selected program.

If a selected program is deleted by pressing on menu option "Delete" with the tempering button, all the program parameters will be emptied. The symbol (⊞) disappears.

**Rename:** Rename the selected program.

You can rename the selected program by touching the tempering button on "Rename".

Then, you can input a new name as required for the program with the keyboard appeared subsequently.

## Safety:

### Password:

In the "Password" menu option, you can lock the menu settings by a 3-digit password (factory setting: 000).

If you forgot your password, please contact our service department.



## Setting:

### Languages:

In the “Languages” menu option, you can select the desired language. A check mark (✓) indicates the language that is set for the system.

### Units:

In the “Units” menu option, you can select the desired unit (°C or °F) for the temperature. A check mark (✓) indicates the unit that is set for the system.

### Display:

In the “Background” menu option you select black or white color for the working screen. In the “Firmware Update Information” menu option, you can activate or deactivate the “Firmware Update Information” screen at the starting of the device. A check mark (✓) indicates that the menu option is activated.

### Sound:

In the “Sound” menu option, you can activate or deactivate the key touch sound. A check mark (✓) indicates that the menu option is activated.

### Factory Settings:

Select the “Factory settings” option, the system requests confirmation to restore the factory settings. Press “OK” button to reset all the system settings to the original standard values set at dispatch from the factory (see “Menu structure”).

### Information:

The “Information” option offers you an overview of the most important system settings of the device.

## Interfaces and outputs

The device can be connected to a PC and operated with the laboratory software labworldsoft® through USB or RS 232 interface.

The device software can also be updated with a PC via the RS 232 or USB port.

**Note:** Please comply with the system requirements together with the operating instructions and help section included with the software.

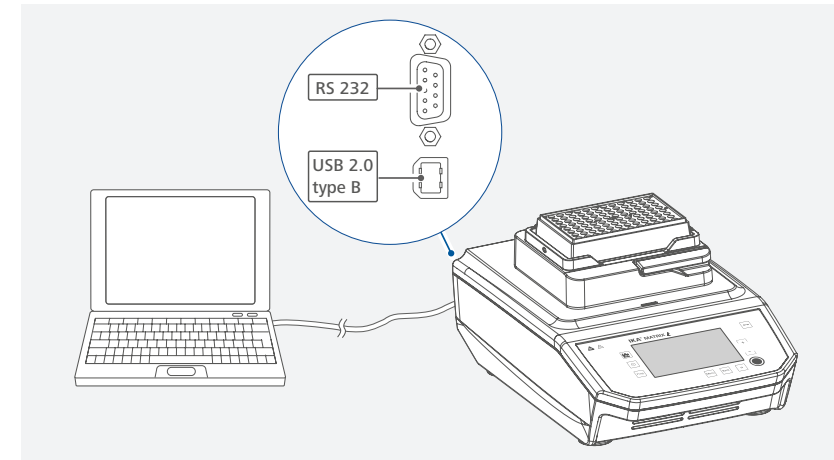

### /// USB interface

The Universal Serial Bus (USB) is a serial bus for connecting the device to the PC. Equipped with USB devices can be connected to a PC during operation (hot plugging). Connected devices and their properties are automatically recognized.

### /// USB device drivers

First, download the latest driver for IKA devices with USB interface.

Install the driver by running the setup file. Connect the IKA device through the USB data cable to the PC. The data communication runs through a virtual COM port.

**Note:** the USB driver is necessary for Windows 10 system. Don't install it for Windows 10 system!



## /// RS 232 interface

Configuration:

- › The functions of the interface connections between the device and the automation system are chosen from the signals specified in EIA standard RS 232 in accordance with DIN 66 020 Part 1.
- › For the electrical characteristics of the interface and the allocation of signal status, standard RS 232 applies in accordance with DIN 66 259 Part 1.
- › Transmission procedure: asynchronous character transmission in start-stop mode.
- › Type of transmission: full duplex.
- › Character format: character representation in accordance with data format in DIN 66 022 for start-stop mode. 1 start bit; 7 character bits; 1 parity bit (even); 1 stop bit.
- › Transmission speed: 9600 bit/s.
- › Data flow control: none
- › Access procedure: data transfer from the device to the computer takes place only at the computer's request.

## /// Command syntax and format

The following applies to the command set:

- › Commands are generally sent from the computer (Master) to the lab device (Slave).
- › The lab device only sends at the computer's request. Even fault indications cannot be sent spontaneously from the lab device to the computer (automation system).
- › Commands are transmitted in capital letters.
- › Commands and parameters including successive parameters are separated by at least one space (Code: hex 0x20).
- › Each individual command (incl. parameters and data) and each response are terminated with Blank CR LF (Code: hex 0x0d hex 0x0A) and have a maximum length of 80 characters.
- › The decimal separator in a number is a dot (Code: hex 0x2E).

The above details correspond as far as possible to the recommendations of the NAMUR working party (NAMUR recommendations for the design of electrical plug connections for analogue and digital signal transmission on individual items of laboratory control equipment, rev. 1.1).

The NAMUR commands and the additional specific IKA commands serve only as low level commands for communication between the device and the PC. With a suitable terminal or communications program these commands can be transmitted directly to the device. The IKA software *labworldsoft®*, provides a convenient tool for controlling the device and collecting data under MS Windows, and includes graphical entry features, for motor speed ramps for example.

Commands	Function
IN_PV_2	Read the actual temperature
IN_SP_2	Read the set temperature
OUT_SP_2 xxx	Set the temperature value to xxx
OUT_SP_12@n	Set the WD-safety temperature with echo of the set (defined) value
OUT_WD1@n	Start the watchdog mode 1 and set the time for the watchdog to n (20...1500) seconds. Echo of the Watchdog time. During a WD1-event, the tempering functions are switched off. This command needs to be send within the watchdog time.
OUT_WD2@n	Start the watchdog mode 2 and set the watchdog time to n (20...1500) seconds. Echo of the watchdog time. During a WD2-event, the set temperature is changed to the WD safety temperature. This command needs to be send within the watchdog time.
RESET	Switch to normal operation mode
START_2	Start tempering function
STOP_2	Stop tempering function
IN_VERSION	Read software version
IN_SOFTWARE_ID	Read software ID and version

### “Watchdog” functions, monitoring of the serial data flow:

If, once this function has been activated (see NAMUR commands), there is no retransmission of the command from the computer within the set time (“watchdog time”), the tempering functions are switched off in accordance with the set “watchdog” function or are changed to the set target values.

The data transmission may be interrupted by, for example, a crash in the operating system, a power failure in the PC or an issue with the connection cable between the computer and the device.

### “Watchdog” – mode 1:

If there is an interruption in data communications (longer than the set watchdog time), the tempering functions are switched off and Error 2 is displayed.

### “Watchdog” – mode 2:

If there is an interruption in data communications (longer than the set watchdog time), the temperature target value is changed to the WD safety temperature limit value. The error message Error 2 is displayed.

## /// Connections between device and external devices

### PC 1.1 Cable:

This cable is required to connect RS 232 port to a PC.

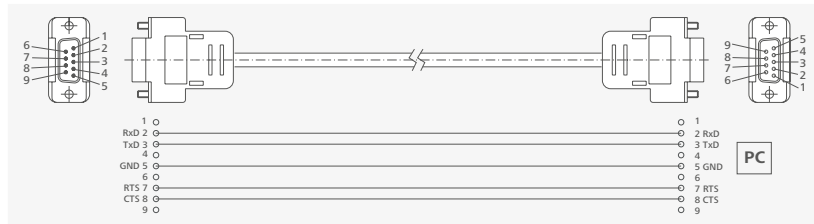

### USB 2.0 Cable (A - B):

This cable is required to connect USB port to a PC.

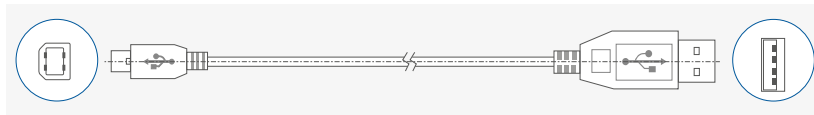

## /// Device firmware update

Keep your device up-to-to-date with the IKA Firmware update tool.

The firmware update can be done with a computer connected through USB-Interface.

For this, you need register on our website MylKA firstly.

After registering your device IKA will inform you about available updates for your devices. Please download the software "FWUToolSetup.zip" from our IKA service website.

## Error codes

Any malfunctions during operation will be identified by an error message on the display.

Proceed as follows in such cases:

- › Turn off the device by using the power switch.
- › Carry out corrective measures.
- › Restart the device.

### Error 02

Error message	› WD1 error or WD2 error
Effect	› Tempering function off
Solutions	› Change watchdog time. › Transmit data from PC within set watchdog time (OUT_WDx@n). › Check cable and plug.

### Error 03

Error message	› Device internal temperature is too high
Effect	› Tempering function off
Solutions	› Switch off the device and allow it to cool down. › Restart the device.

### Error 05

Error message	› Temperature can not reach the set value after a certain time.
Effect	› Tempering function off
Solutions	› Switch off and restart the device. › Send device for repair if the error message appear again.

### Error 24

Error message	› Temperature overshoot error
Effect	› Tempering function off
Solutions	› Switch off the device and allow it to cool down. › Send device for repair if the error message appear again.

If the action described fails to resolve the fault or another error code is displayed then take one of the following steps:

- › Contact the service department
- › Send the device for repair, including a short description of the fault.

## Maintenance and cleaning

The device is maintenance-free. It is only subject to the natural wear and tear of components and their statistical failure rate.

### /// Cleaning

For cleaning disconnect the mains plug!

Use only cleaning agents which have been approved by IKA to clean the devices:

These are: water (containing surfactant) and isopropyl alcohol.

- › Wear protective gloves during cleaning the devices.
- › Electrical devices may not be placed in the cleansing agent for the purpose of cleaning.
- › Do not allow moisture to get into the device when cleaning.
- › Before using another than the recommended method for cleaning or decontamination, the user must ascertain with that this method does not destroy the device.

### /// Ordering spare parts

When ordering spare parts, please indicate:

- › Device type.
- › Serial number, see type plate
- › Item and designation of the spare part, spare parts diagram and spare parts list.
- › Software version (Briefly visible in the display when the device is switched on).

### /// Repairs

**Please send in device for repair only after it has been cleaned and is free from any materials which may constitute a health hazard.**

For repair, please request the “Decontamination Certificate” from **IKA**, or download printout of it from the **IKA** website.

If you require servicing, return the device in its original packaging. Storage packaging is not sufficient. Please also use suitable transport packaging.

## Accessories

Exchangable attachments	Tubes / Plates	Max. Temperature	Min. Temperature
IKA MATRIX ATTACHMENT 0.5 ML	24 x 0.5 ml micro test tubes	100 °C	RT - 30 °C
IKA MATRIX ATTACHMENT 1.5 ML	24 x 1.5 ml micro test tubes	100 °C	RT - 30 °C
IKA MATRIX ATTACHMENT 2.0 ML	24 x 2.0 ml micro test tubes	100 °C	RT - 30 °C
IKA MATRIX ATTACHMENT 12 MM	24 x 11 mm to 11.9 mm micro test tubes	110 °C	RT - 30 °C
IKA MATRIX ATTACHMENT CRYO	24 x 1.5 ml or 2.0 ml Cryo test tubes	110 °C	RT - 30 °C
IKA MATRIX ATTACHMENT 5.0 ML	8 x 5.0 ml micro test tubes	100 °C	RT - 30 °C
IKA MATRIX ATTACHMENT 15 ML	8 x 15 ml micro test tubes	100 °C	RT - 30 °C
IKA MATRIX ATTACHMENT 50 ML	4 x 50 ml micro test tubes	100 °C	RT - 30 °C
IKA MATRIX ATTACHMENT PCR 96	96 x 0.2 ml PCR tubes 1 x 96-well PCR plate	100 °C	RT - 30 °C
IKA MATRIX ATTACHMENT PCR 384	1 x 384-well PCR plates	100 °C	RT - 30 °C
IKA CARRIER	1 x MTP 1 x DWP	100 °C	RT - 30 °C
IKA COVER	For IKA PCR 96, IKA PCR 384, IKA 0.5 ml, IKA 1.5 ml, IKA 2.0 ml and IKA CARRIER (MTP & DWP). <b>Note:</b> For even tempering and to protect the samples from unwanted exposure to light.		
IKA THERMOCOVER	For IKA PCR 96, IKA PCR 384, IKA 0.5 ml, IKA 1.5 ml, IKA 2.0 ml and IKA CARRIER (MTP & DWP). <b>Note:</b> Prevent the formation of condensate on vessel walls or vessel lids.		



## Technical data

General data		
Voltage	VAC	100... 240 ± 10 %
Frequency	Hz	50 / 60
Power input max.	W	230
Fuse		T4A 250V (2x)
Interface		USB, RS 232
Operating mode		Timer / continuous operating / Program
Permitted on-time	%	100
Permissible ambient temperature	°C	+5 ... +40
Permissible relative humidity	%	80
IP code according to EN 60529		IP 21
Safety class		I
Overvoltage category		II
Pollution degree		2
Dimensions (W × D × H)	mm	216 × 351 × 127
Weight	kg	9.5
Operation at a terrestrial altitude	m	max. 2000
Tempering function		
Heat output	W	100
Heating rate	K / min	5.5
Cooling power	W	72
Cooling rate	K / min	2
Working temperature min.	°C	RT - 30
Temperature setting min.	°C	- 10
Temperature setting max.	°C	110 (depending on exchangeable attachments)
Safety temperature limit	°C	145 (fixed)
Temperature setting		Buttons
Temperature setting resolution	K	1.0
Temperature display		TFT LCD
Temperature display resolution	K	0.1
Temperature control accuracy	K	± 0.5
Temperature stability	K	± 0.5
Temperature homogeneity	K	± 0.5

Timer function		
Timer / Counter range		0 second ... 99 hours 59 minutes 59 seconds
Timer display		TFT LCD
Timer setting		Buttons
Timer setting resolution		1 second

Subject to technical changes!

## Warranty

In accordance with IKA warranty conditions, the warranty period is 24 months. For claims under the warranty please contact your local dealer. You may also send the machine direct to our factory, enclosing the delivery invoice and giving reasons for the claim. You will be liable for freight costs. The warranty does not cover worn out parts, nor does it apply to faults resulting from improper use, insufficient care or maintenance not carried out in accordance with the instructions in this operating manual.