

IKA

designed for scientists

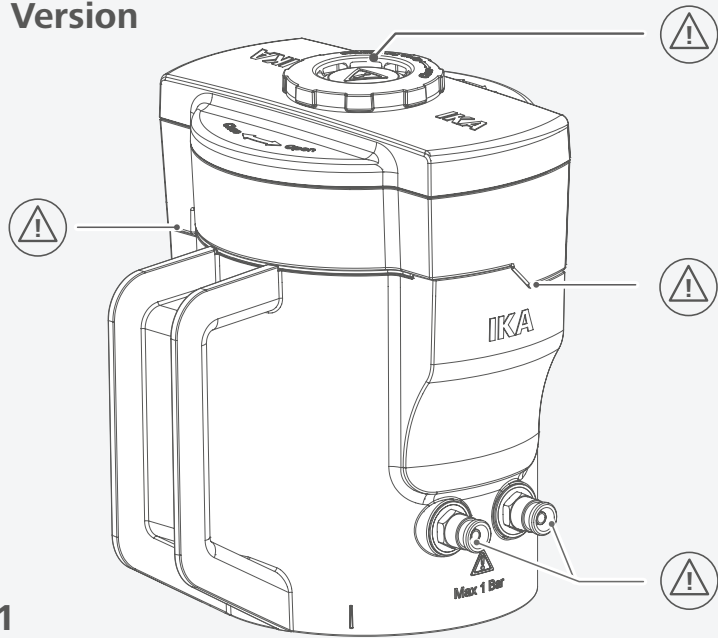



MultiDrive MI 250 (- S)
MultiDrive MI 400 (- S)
MultiDrive MI 250 T (- S)
MultiDrive MI 400 T (- S)

New Version

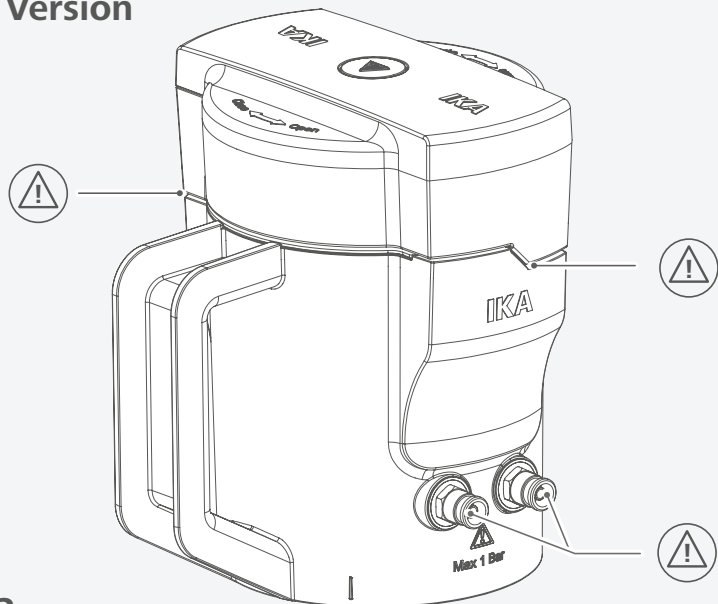

First Version







	Explication of warning symbols	6
	Safety instructions.....	7
	Unpacking	8
	Useful information	9
	Installation.....	14
	Maintenance and cleaning.....	20
	Accessories	28
	Warranty	28
	Technical Data	29





Explication of warning symbols

/// Warning symbols

-  **Danger!** Indicates an (extremely) hazardous situation, which, if not avoided, will result in death, serious injury.
-  **Warning!** Indicates a hazardous situation, which, if not avoided, can result in death, serious injury.
-  **Caution!** Indicates a potentially hazardous situation, which, if not avoided, can result in injury.
-  **Notice!** Indicates practices which, if not avoided, can result in equipment damage.

/// General Symbols

A — Position number

-  Correct / Result
Shows the correct execution or the result of an action step.
-  Wrong
Shows the incorrect execution of an action step.
-  Note
Displays action steps that require particular attention to detail.

Safety instructions



/// General information

- > **Read the operating instructions completely before starting up and follow the safety instructions.**
- > Keep the operating instructions in a place where it can be accessed by everyone.
- > Ensure that only trained staff work with the device.
- > Follow the safety instructions, guidelines, occupational health and safety and accident prevention regulations.
- > The vessel must only be used in a technically perfect condition.
- > Refer to the operating instructions for the drive unit.

-  **Danger!**
- > Please observe the relevant safety instructions and guidelines regarding dust explosions.

-  **Caution!**
- > Wear your personal protective equipment in accordance with the hazard category of the medium to be processed, there is a risk of:
 - body parts, hair, clothing and jewellery getting caught
 - sharp blade edges.

-  **Notice!**
- > Pay attention to the marked sites in Fig. 1.
- > Protect the vessel from bumping and impacting.
- > Do not use any damaged vessel e.g. with hairline cracks or splits.
- > Check the vessel beforehand for damage each time when you use them. Do not use damaged components.

/// Device setup

-  **Notice!**
- > Ensure that the vessel and the cover is firmly attached to the drive unit prior to operating the device.
- > The drive unit cannot be operated without a closed vessel.

/// Working with the vessel

-  **Danger!**
- > With substances capable of forming an explosive mixture, appropriate safety measures must be applied, e.g. working under a fume hood.
- > To avoid body injury and property damage, observe the relevant safety and accident prevention measures when processing hazardous materials.

-  **Warning!**
- > Only process samples that will not react dangerously to the extra energy produced through processing. This also applies to any extra energy produced in other ways, e.g. through light irradiation.



⊗ Caution!

- › Please pay attention to avoiding hand injury when operate and clean the vessel.
- › The vessel and inside medium may be very hot after operation. Allow it to cool down before opening the vessel. Use your personal protective equipment.

⚠ Notice!

- › The vessel must always be closed during operation. Switch off the drive unit immediately if any material leaks from the vessel. Clean the device after disconnected power plug.
- › **MultiDrive MI 250 / MI 400 / MI 250 T / MI 400 T:** No liquid medium can be processed in the vessel. The sealing is only suitable for dry material.
- › Hose connection suitable for cooling liquid up to max. 0.5 bar.
- › When using dry ice, note the freezing point of the coolant in the cooling circuit and the increase in pressure in closed vessels.
- › The processing time is limited (depending on the vessel, see "Technical data"). The vessel must be allowed to cool down for a few minutes before processing the sample further in the vessel.



Unpacking

- › Please unpack the vessel carefully.
- › Any damage should be notified immediately to the shipping agent (post office, railway network or logistics company).

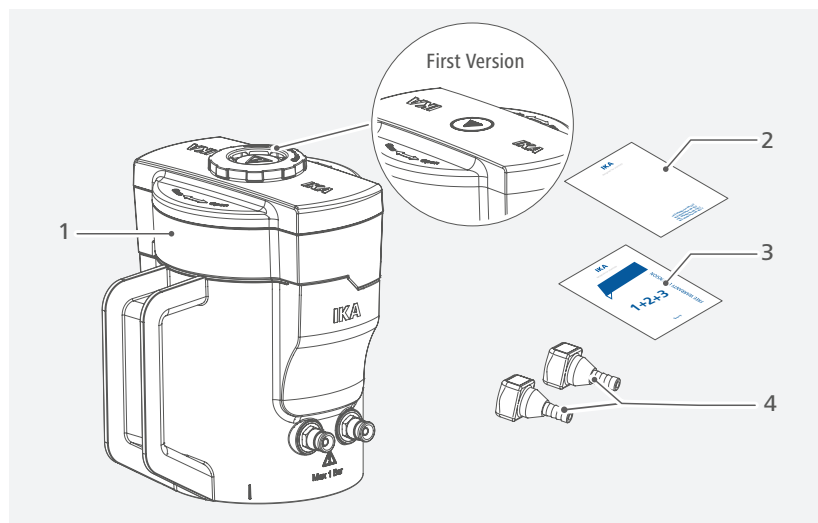

1	MultiDrive MI 250 (- S) or MultiDrive MI 400 (- S) or MultiDrive MI 250 T (- S) or MultiDrive MI 400 T (- S)
2	User guide
3	Warranty card
4	Hose connection for cooling circuit (2 x)

Useful information

This series grinding vessels are designed for use in combination with **MultiDrive basic / control** for dry / wet milling.

MultiDrive MI 250 / MI 400 / MI 250 T / MI 400 T:

The standard version grinding vessels are designed for dry milling only! Never fill liquid to them or use them for wet milling!

MultiDrive MI 250 - S / MI 400 - S / MI 250 T - S / MI 400 T - S:

The sealed version grinding vessels have "sealed" grinding tool kits. They can be used for both dry milling and wet milling with liquid.

MultiDrive MI series vessel information and designation explanation:

IKA Designation	Max. Useful Volume [ml]	Integrated Temperature Sensor	Application	Recommend for Drive Unit
MultiDrive MI 250	250	No	Drying Milling	MultiDrive basic MultiDrive control
MultiDrive MI 400	400	No	Drying Milling	MultiDrive basic MultiDrive control
MultiDrive MI 250 T	250	Yes	Drying Milling	MultiDrive control
MultiDrive MI 400 T	400	Yes	Drying Milling	MultiDrive control
MultiDrive MI 250 - S	250	No	Drying Milling Wet Milling	MultiDrive basic MultiDrive control
MultiDrive MI 400 - S	400	No	Drying Milling Wet Milling	MultiDrive basic MultiDrive control
MultiDrive MI 250 T - S	250	Yes	Drying Milling Wet Milling	MultiDrive control
MultiDrive MI 400 T - S	400	Yes	Drying Milling Wet Milling	MultiDrive control

Nomenclature for **MultiDrive MI** series vessel:

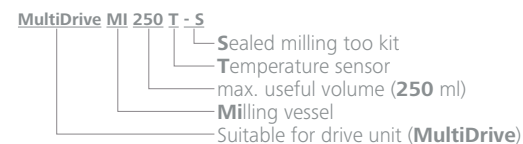

⚠ Notice!

Please check and ensure your vessel is suitable for wet milling before filling liquid:

Tips: how to distinguish the sealed version from the standard version grinding vessel?

From the bottom of vessels:

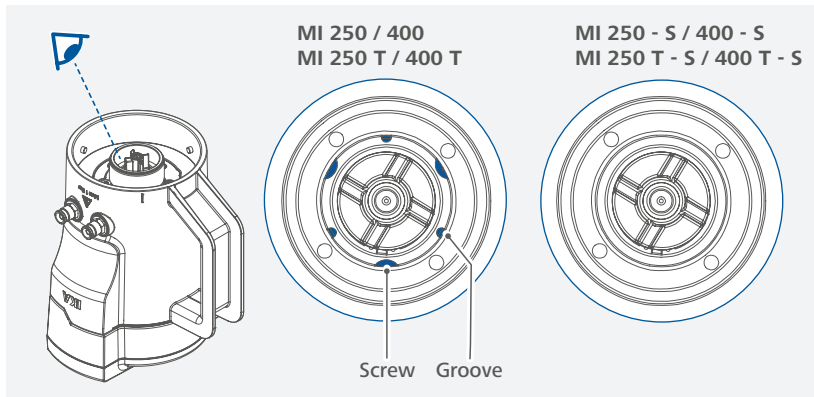

From the inside "sealed" mark of vessels:

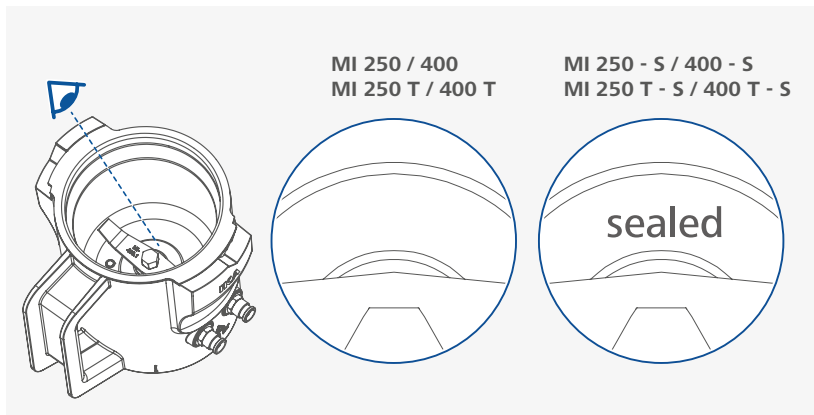

Note: the "sealed" mark may disappear due to wear and tear!

Note: MultiDrive MI 250 T (- S) / MI 400 T (- S) has integrated temperature / RFID sensor. When used in combination with the **MultiDrive control**, it can be used to measure and limit the sample temperature as well as to record the operating time and set the maintenance time.

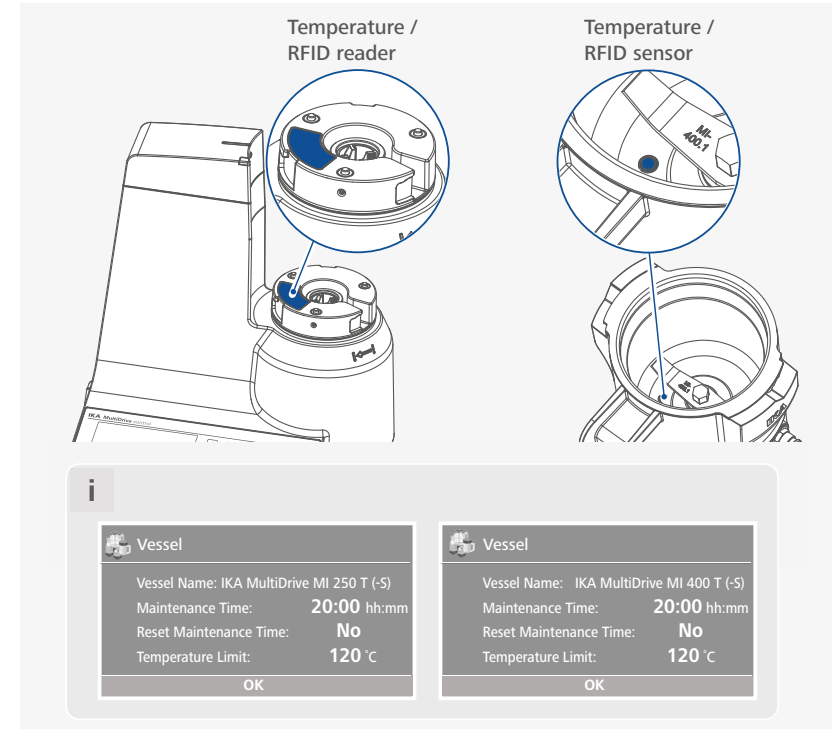

⚠ Notice!

Even drive unit **MultiDrive control** cannot distinguish a sealed version vessel. Please check and ensure your vessel is suitable for wet milling before filling liquid!

The temperature measurement with the vessel **MultiDrive MI 250 T (- S) / MI 400 T (- S)** works exclusively with the **MultiDrive control**. When the "Temperature Limit" is set in **MultiDrive control** that the device stops after the temperature is reached. With the setting, both sample and the vessel can be protected from overheating.

Note: The temperature measurement is useful to measure / limit the temperature increase of the medium during the operation. It is not for a long time measurement of the room temperature or medium temperature without operation!

The temperature sensor react slowly without operation. When hot or cold medium is filled into the empty vessel, it need some time for **MultiDrive control** to show the right temperature. During operation the sensor react very fast and the **MultiDrive control** can show the right temperature fast.

The temperature measurement can be inhomogeneous, especially if the cooling function is working and the operation stops or the medium flow inside the vessel and stops partly because of sticky medium.

Caution!

The temperature can be much higher on the beater or other parts of the vessel independent from the temperature which is shown on the **MultiDrive control** display.

Notice!

In order to avoid to damage the integrate temperature sensor of the vessel by overheating, the **MultiDrive MI 250 T (- S) / MI 400 T (- S)** milling vessel can be used for grinding material with hardness up to 5 Mohs.

The vessels **MultiDrive MI 250 T (- S) / MI 400 T (- S)** has also an operating hours counter. This works exclusively with the **MultiDrive control**. This drive unit can detect the operating hours of the vessel and indicate when the next maintenance is required for the vessel. The operating hours counter can also be used to monitor cleaning intervals. In this case shorter times can be set.

Note: For more information on temperature measurement and maintenance intervals, please refer to the operating instructions of the drive unit.

Impact milling:

The milling vessel with a beater (standard beater: **MultiDrive MI 250.1 / MI 400.1**) can grind soft, medium hard and brittle materials with a Mohs' scale of hardness of up to 5.

For harder material, the wear and tear on the grinding tool is high and grinding therefore becomes uneconomical.

For grinding hardness greater than 5 Mohs, we recommend special hard metal beater (**MultiDrive MI 250.3 / MI 400.3**, not included with the vessel). With it, the device can be used for grinding hard and brittle materials with a Mohs' scale of hardness of up to 9. This prevents the sample from being contaminated by bits of the grinding tool broken off by wear and tear.

Everything that breaks, is dry, and does not have a high fat content can be ground.

Following is a list of some materials that can be ground dry:

Wheat, barley, corn, malt, pectin, roasted coffee, nutshells, bones, ergot, peat, feed materials, spices, resin, potash, seeds, salts, cinders, tablets.

The feed grain size should not be larger than 7 mm.

Tough grinding material must be cooled, for example by adding pulverized dry ice to the grinding vessel.

Cutting milling:

The milling vessel with the cutting blade **MultiDrive MI 250.2 / MI 400.2** (not included with the vessel) can grind bulky, elastic fibrous and soft materials with high cellulose content.

Mixed goods such as trash must be free of iron and non-iron metals. The feed material must not be too moist or fatty. Otherwise, the material may adhere to the sides of the grinding container.

Following is a list of some materials that can be reduced:

Leaves, fibers, hops, cardboard, paper, hay, plastics, tobacco and roots.

The feed granularity should not be larger than 10 mm.

Note: Materials that are not listed in these operating instructions may only be handled with the grinding vessel after confirmed with IKA, especially if there is a risk of explosion (dust explosion due to electrostatic charge).

Working with cooling water:

There are two connections for the cooling circuits on the vessel. We recommend hoses with dimensions of Ø 6.0 (inside diameter) x 1.5 mm. Then, the device can be cooled with tap water or an IKA recirculating chiller via these hoses.

Note: The pressure in the cooling circuit must not exceed 0.5 bar.

The grinding chamber can only be filled to half of the maximum filling quantity especially when material containing oils and similar materials are ground.

If more refrigeration is required, the ground material should be cooled prior to being put into the grinding chamber.

Note the freezing point of the coolant in the cooling circuit when using dry ice.

Working with coolants – Dry ice (CO₂) cooling:

Please observe the safety instructions!

Grinding causes the mill feed to heat up. This may not always be desirable as the mill feed can change when heated (e.g. increased oxidation, loss of moisture, evaporation of volatile components, etc.).

It may only be possible to crush mill feed which is viscous or has a high fat content by embrittling using coolants.

Working with the coolants dry ice (CO₂):

- > Put the feed material into the grinding vessel.
- > Add crushed dry ice.
- > Thoroughly mix the dry ice with the feed material.
- > Attach the grinding vessel cap when the dry ice is completely vaporized, otherwise high pressure may build up in the grinding chamber.

Note: That the mill feed heats up again extremely quickly during grinding (it may reach room temperature again after approximate 10 seconds of grinding). You may have to repeat the process several times if the product is not adequately ground after one cooling process.

Warning!

Dry ice is solid carbon dioxide that expands into a gas. You can lose of consciousness, if dry ice vapors are inhaled directly over a longer period of time. Use dry ice only in a well ventilated place.

Dry ice is extremely cold (-109 °F/ -78 °C). Avoid contact with skin and eyes.

When using dry ice, observe the applicable accident prevention regulations.



Installation

/// Attaching the vessel to the drive unit

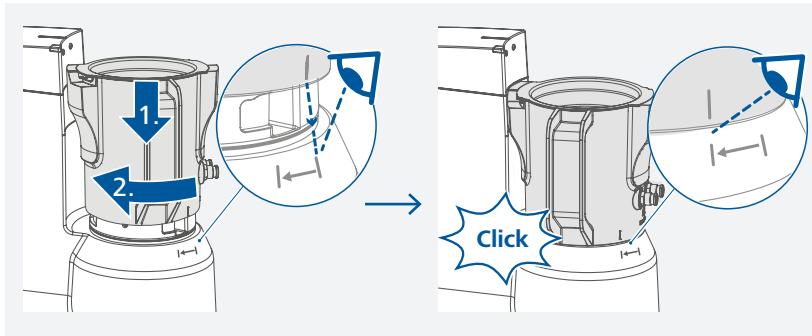

/// Filling the vessel

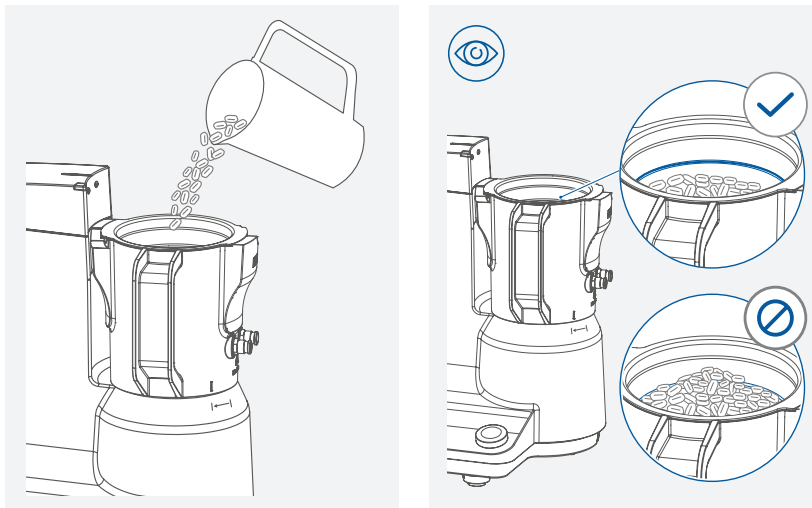

⚠ Notice!

Pay attention to the maximum filling level!

/// Closing the vessel

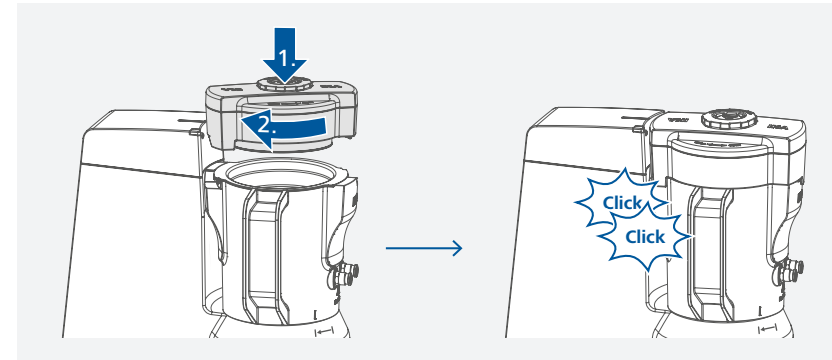

/// Switching on the drive unit

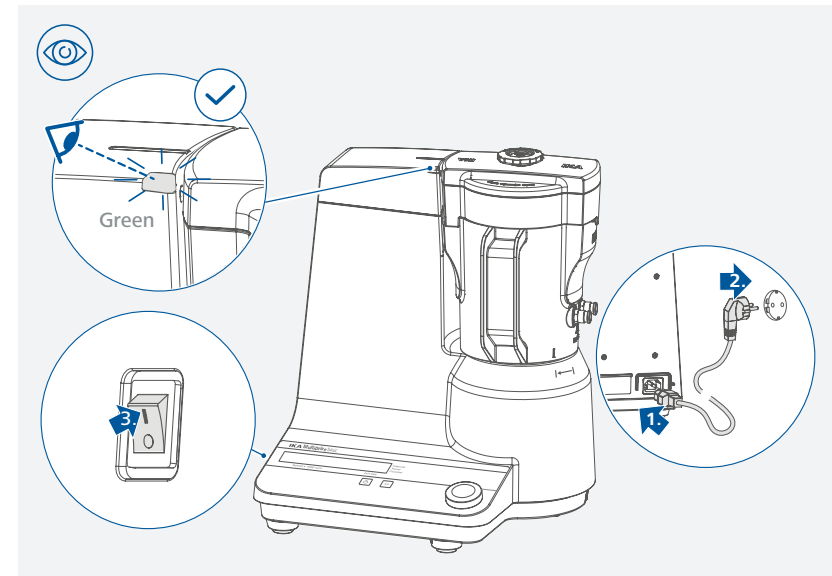

Note: After the cap has been securely closed, the color of the LED signal lamp changes from red to green. The unit is only ready for operation when the LED is green.

⚠ Caution!

When the drive unit is running, the hot dust may emit from the vent. Don't put your hand on the top of the cover!

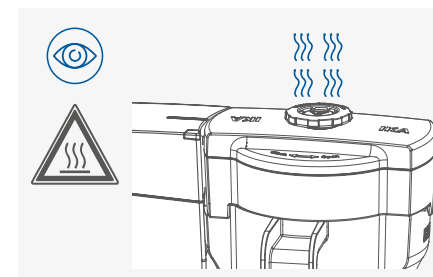

/// Connecting the cooling circuit

When cooling the vessel with tap water, proceed as following:

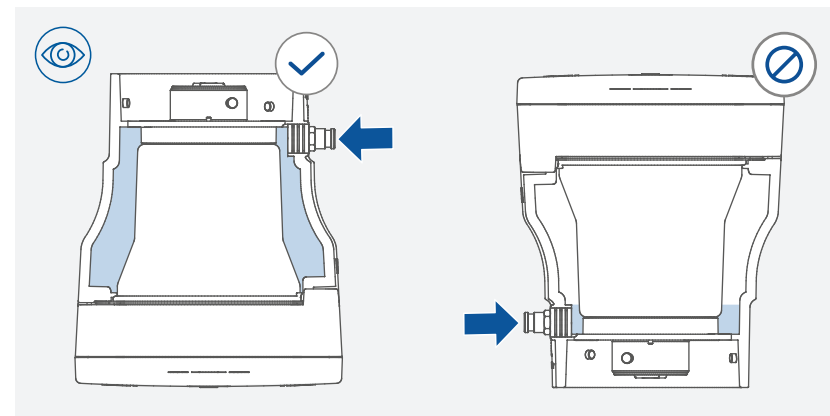
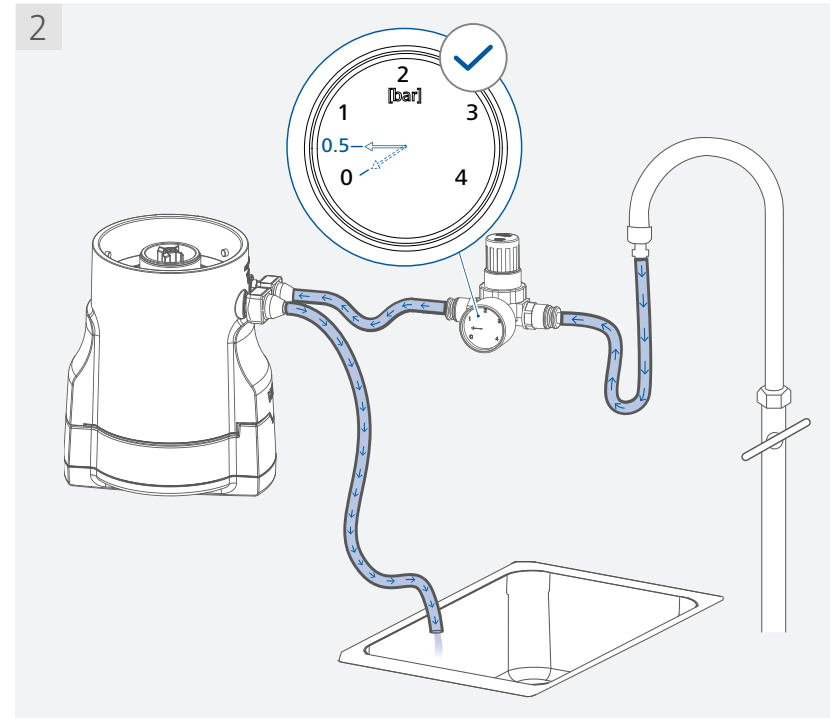
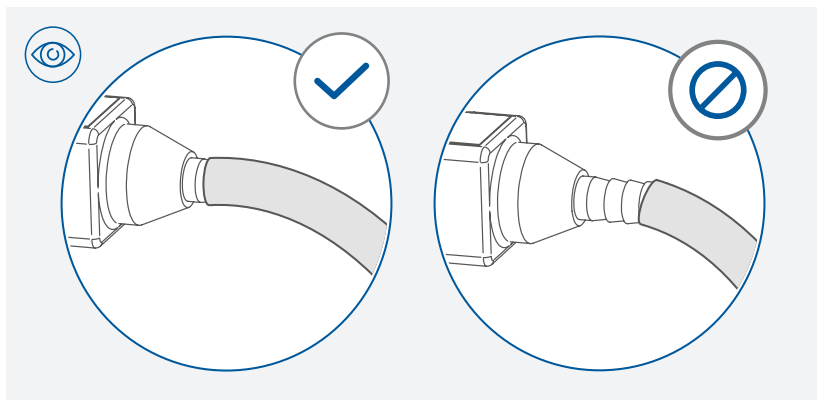
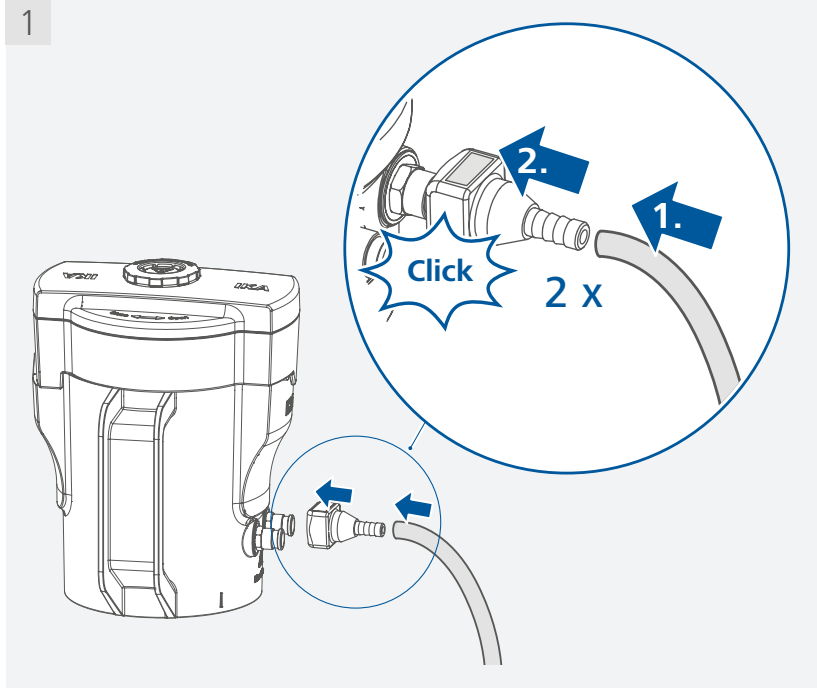

Note: during the filling process, turn the vessel upside down. After water comes out of the outlet hose, the system is filled. Then, turn back and install the vessel to the drive unit for operation.

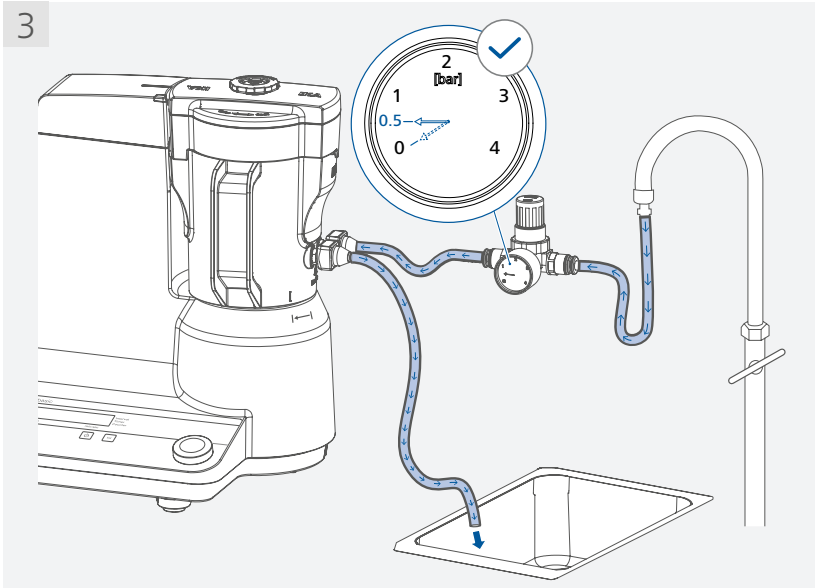

Hose recommendation: Ø 6.0 (inside diameter) x 1.5 mm.
Max. permissible pressure in cooling circuit 0.5 bar.

⚠ Notice!

Ensure both hoses are connected before filling water to the cooling circuit. Slowly increase the water pressure to prevent the hoses from slipping. IKA recommends to use a pressure regulating valve for safely limit the pressure to 0.5 bar. After cooling, close the water valve firstly. Then, disconnect the hoses and the hose connections.

When disconnecting the hoses and hose connections, proceed as below:

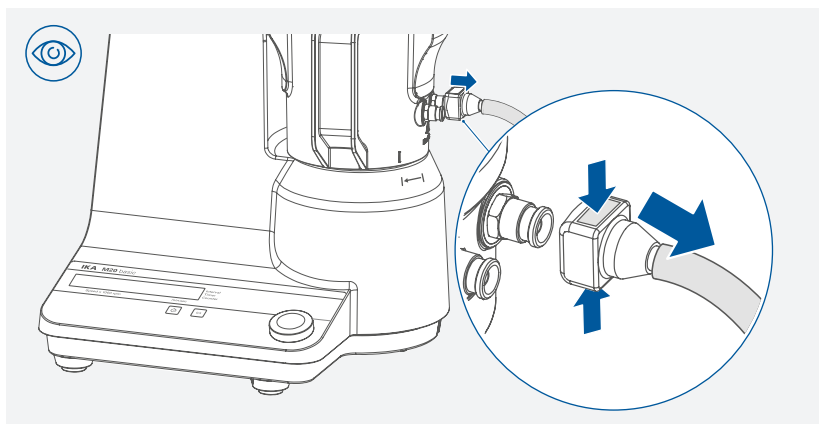

⚠ Notice!

When removing the vessel after milling, we advise to disconnect the hoses and hose connections together.

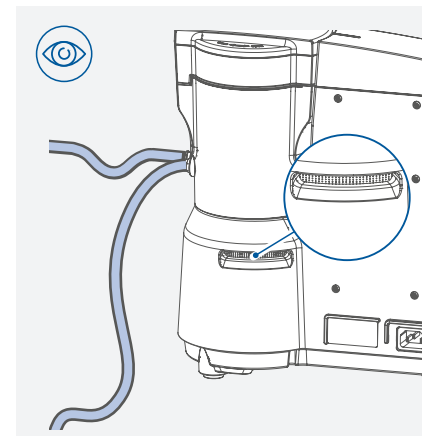

⊗ Danger!

When cooling water is connected, ensure that cooling water must not spray into the venting slot of the drive unit!

/// Empty the cooling circuit

⚠ Notice!

Empty the cooling liquid completely, if you use the vessel without cooling. Otherwise, the temperature will increase and therefore the increased pressure in the closed cooling system can destroy the seals and the cooling liquid could flow out. Please note both hoses connections should be connected in order to empty the cooling liquid! The hose connections have built-in valves. The cooling liquid can be drained out only when both hoses connections are connected.

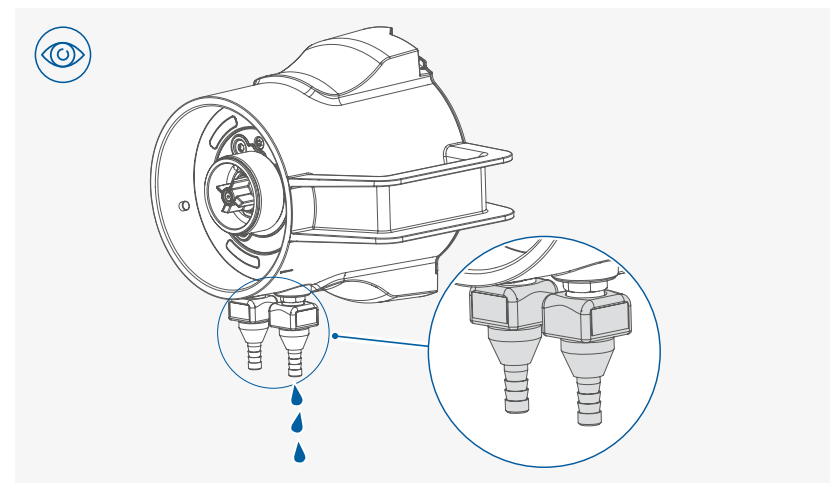

Maintenance and cleaning

The vessel is maintenance-free. It is only subject to the natural wear and tear of components and their statistical failure rate.

/// Cleaning

- › Use only cleaning agents which have been approved by IKA to clean the vessel:
These are: water (containing surfactant) and isopropyl alcohol.
- › Before using another than the recommended method for cleaning or decontamination, the user must ascertain with that this method does not destroy the device.
- › Wear protective gloves during cleaning the vessel.

Clean dirty parts with a cleaning brush included with the drive unit.

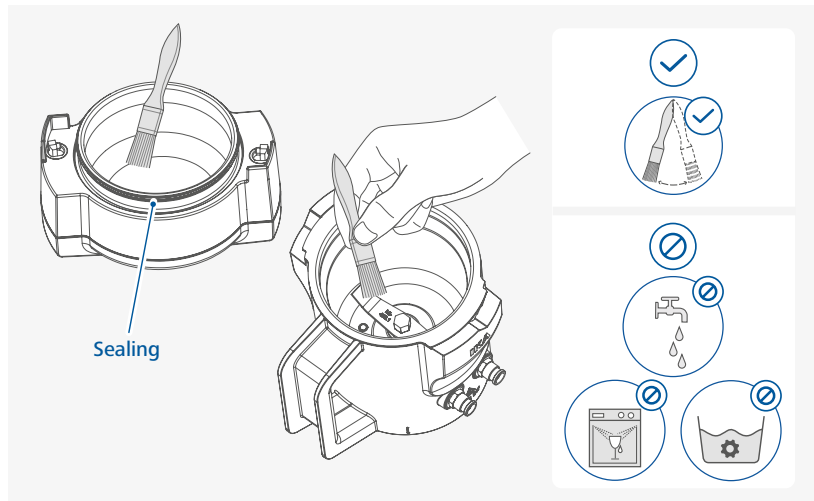

You can also clean the dirty parts with a vacuum cleaner.

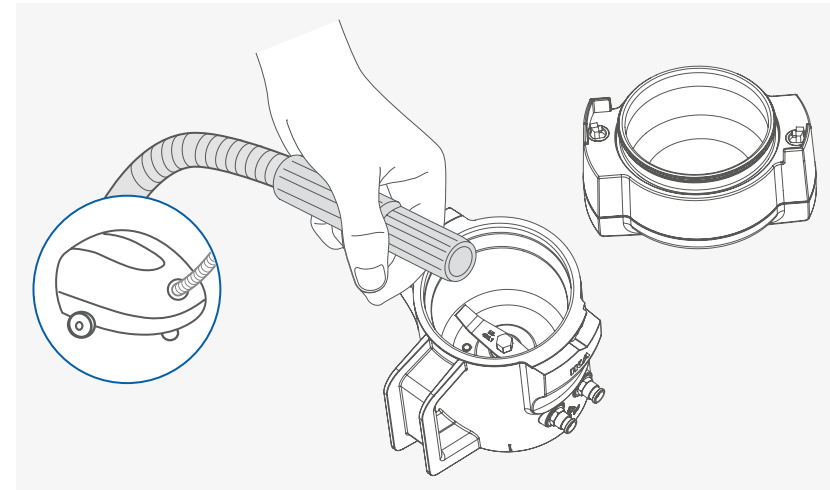

⚠ Notice!

Don't damage the sealing on the vessel cap when cleaning!

If there is heavy accumulation of dirt on the vessel, it can be cleaned with wet cloth after disassembly. Disassembly tools are included in the delivery scope of the drive unit. Disassembly of the vessel for intensive cleaning of the individual parts:

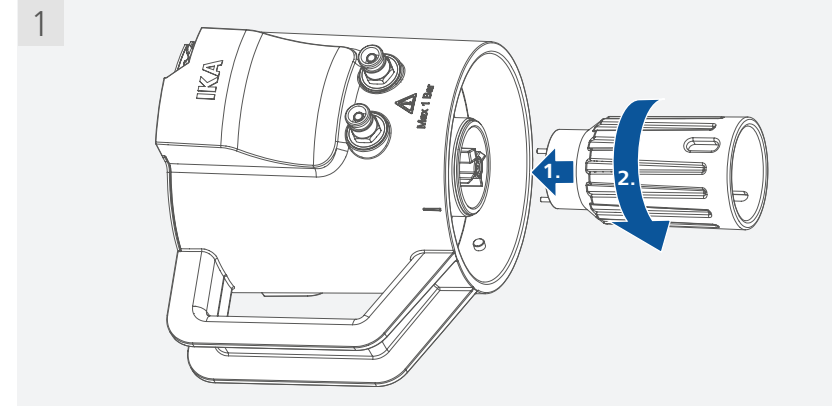

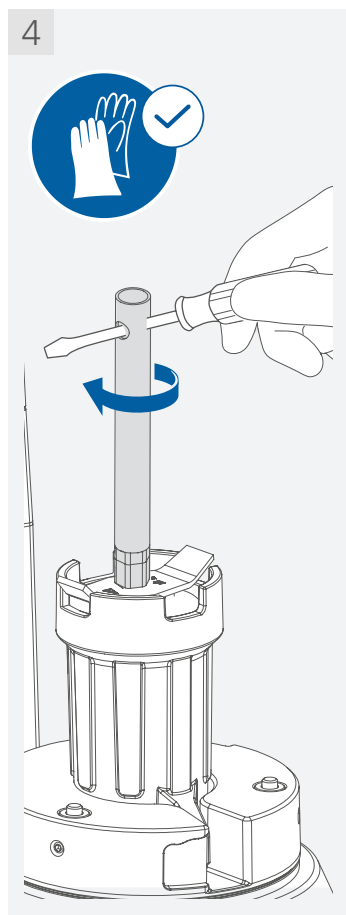
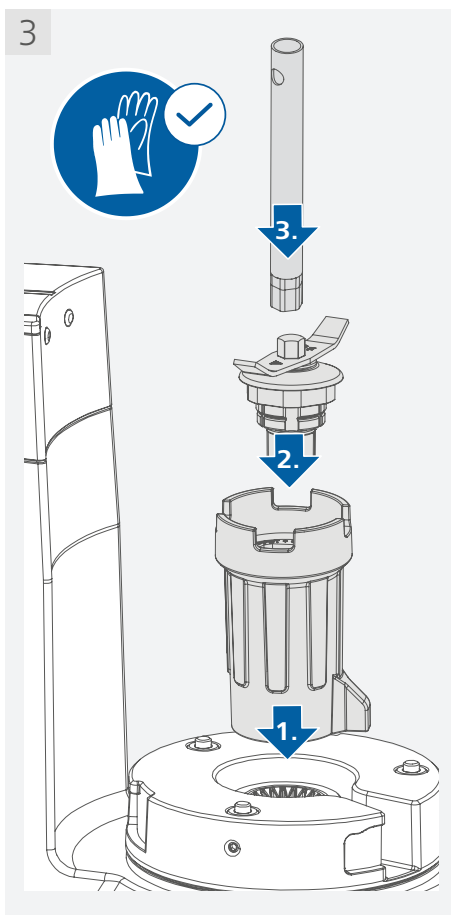
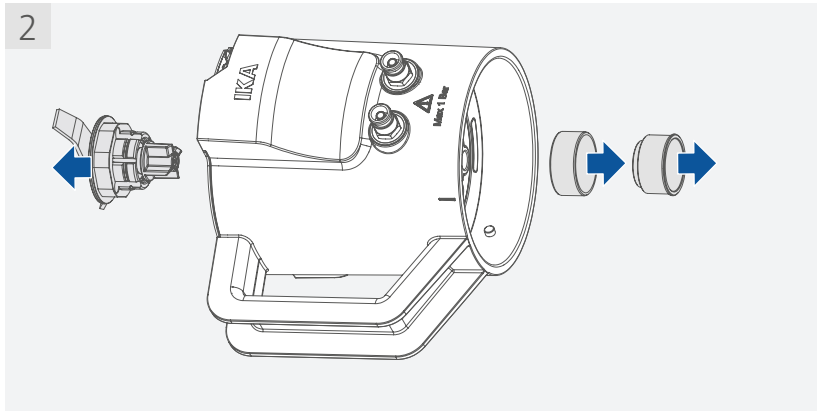

⚠ Caution!

The edges of the grinding tool are sharp. Wear protective gloves for handling and please observe the safety instructions.

To loosen the retaining nut of the grinding tool, turn the socket wrench in clockwise direction (left-hand thread)!

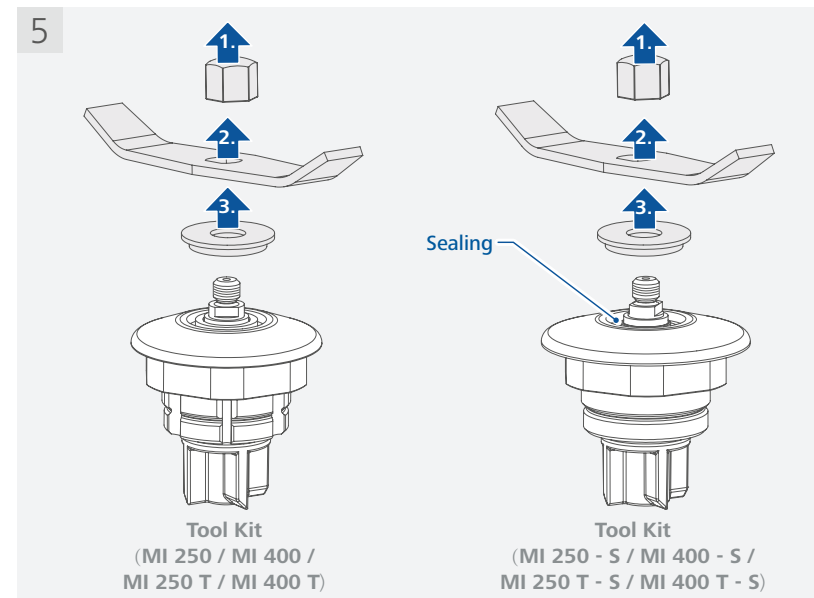

MI 250 / MI 400 / MI 250 T / MI 400 T:

For thoroughly cleaning, the bearing carrier can be disassembled and cleaned the inside with the cleaning brush or vacuum cleaner.

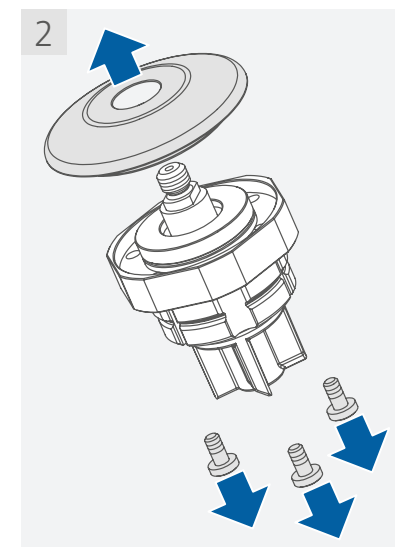
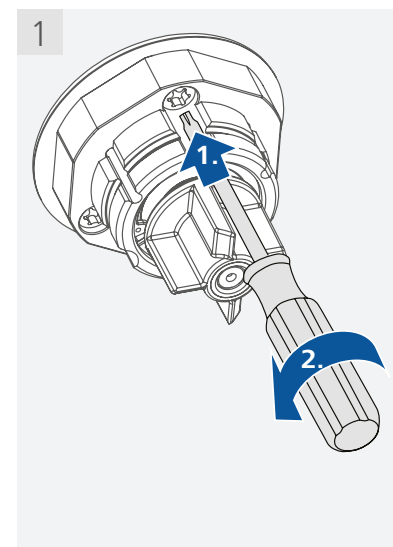

3 (a)

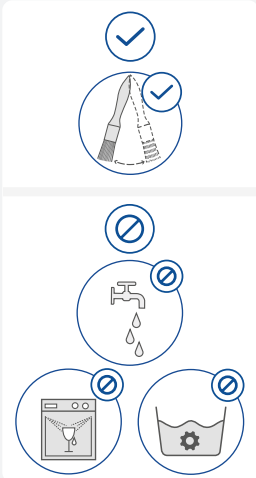
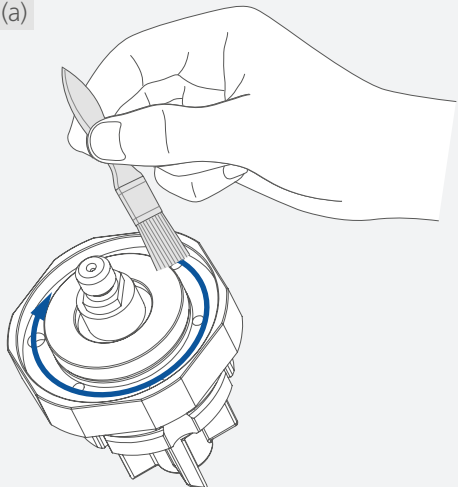

3 (b)

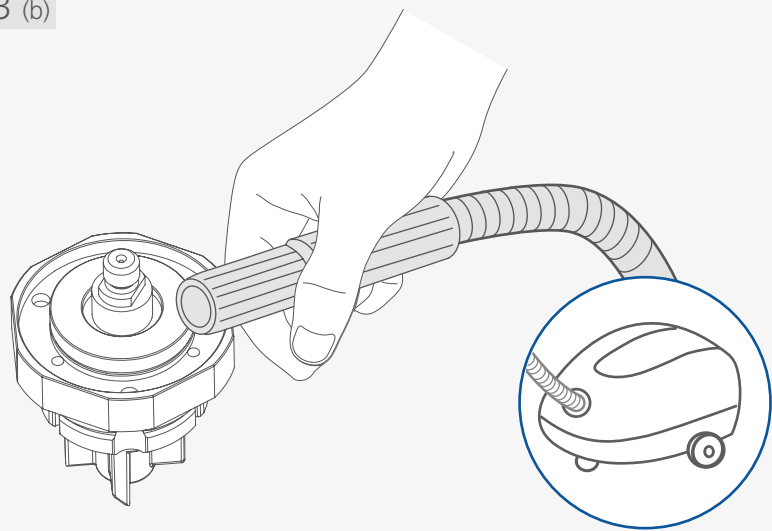

MI 250 - S / MI 400 - S / MI 250 T - S / MI 400 T - S:

Clean the groove in bearing carrier with cleaning brush or or vacuum cleaner.

1 (a)

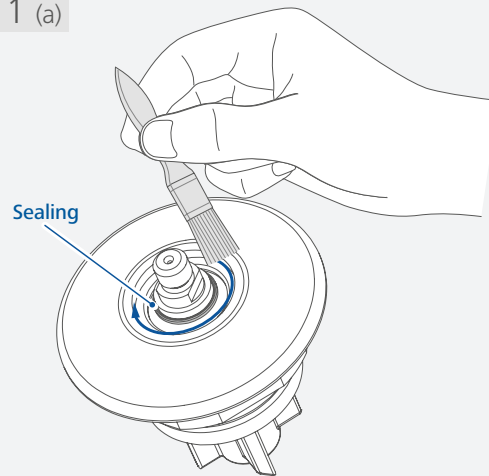

2 (b)

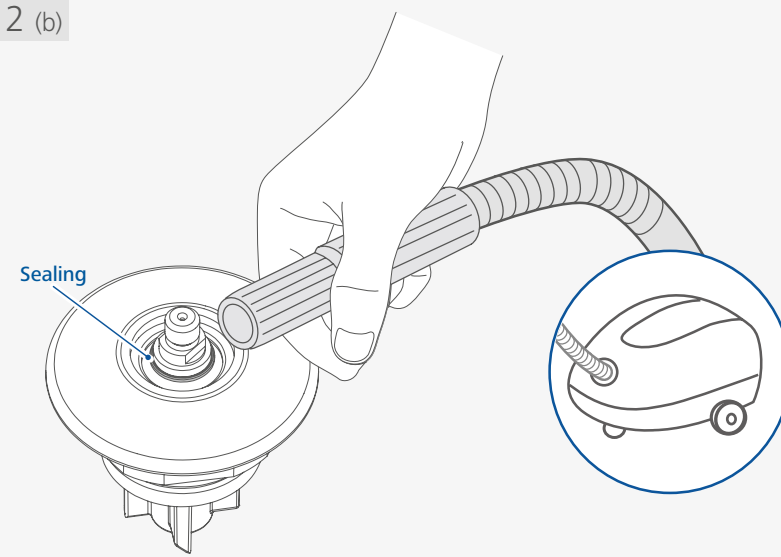

⚠ Notice!

Don't damage the sealing when cleaning! Don't use sharp tools to clean the sealing!



The small cap should be disassembled and cleaned regularly.

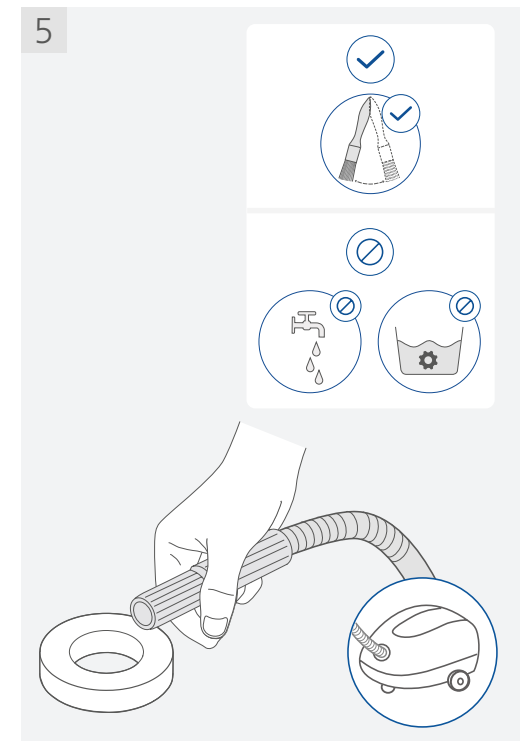
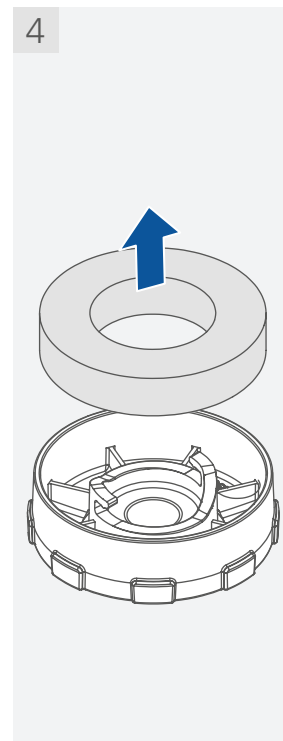
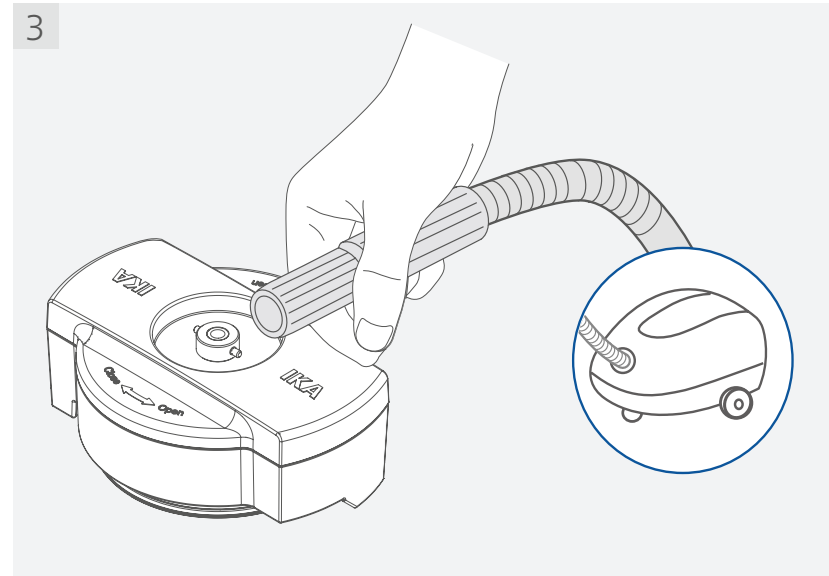
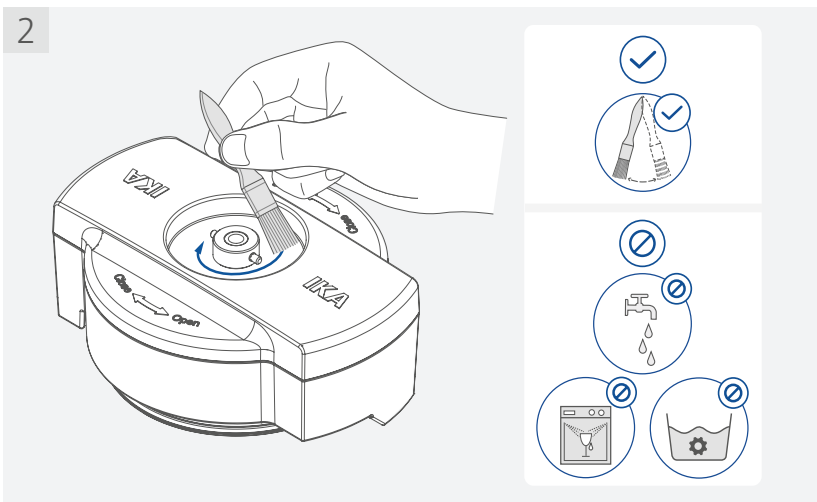
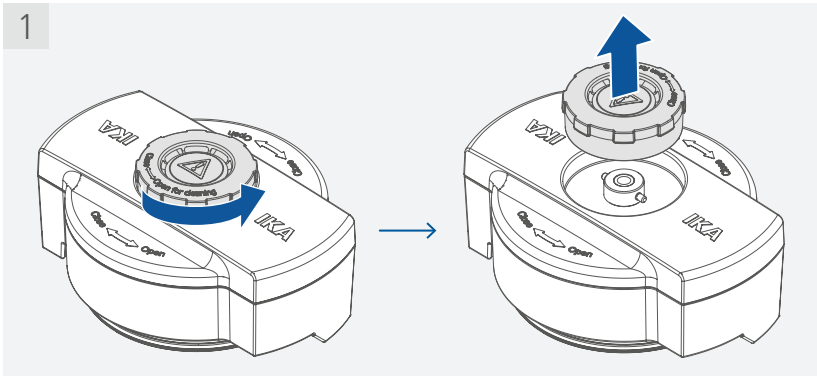

⚠ Notice!

After cleaning, ensure the dust filter is put back to the small cap before assembling!

/// Ordering spare parts

When ordering spare parts, please indicate:

- > Vessel type.
- > Item and designation of the spare part, spare parts diagram and spare parts list.

/// Exchanging and replacing the grinding tool

The grinding tool can be disassembled (see section "Cleaning").

When changing the grinding tool directly after a grinding procedure, the grinding tool is hot!

Let it cool down before handling it!

Before assembling a new or another grinding tool, make certain that all parts are clean!

/// Repairs

Please send in device for repair only after it has been cleaned and is free from any materials which may constitute a health hazard.

For repair, please request the "Decontamination Certificate" from IKA, or download print-out of it from the IKA website.

If you require servicing, return the device in its original packaging. Storage packaging is not sufficient. Please also use suitable transport packaging.

Accessories

MultiDrive MI 250 (- S) / MI 400 (- S):

- > **MultiDrive MI 250.1** Standard beater
- > **MultiDrive MI 400.1** Standard beater
- > **MultiDrive MI 250.2** Star-shaped cutter
- > **MultiDrive MI 400.2** Star-shaped cutter
- > **MultiDrive MI 250.3** Hard metal beater
- > **MultiDrive MI 400.3** Hard metal beater

MultiDrive MI 250 T (- S) / MI 400 T (- S):

- > **MultiDrive MI 250.1** Standard beater
- > **MultiDrive MI 400.1** Standard beater
- > **MultiDrive MI 250.2** Star-shaped cutter
- > **MultiDrive MI 400.2** Star-shaped cutter

See more accessories on www.imlab.eu.

Warranty

In accordance with IKA warranty conditions, the warranty period is 24 months. For claims under the warranty please contact your local dealer. You may also send the machine direct to our factory, enclosing the delivery invoice and giving reasons for the claim. You will be liable for freight costs.

The warranty does not cover worn out parts, nor does it apply to faults resulting from improper use, insufficient care or maintenance not carried out in accordance with the instructions in this operating manual.

Technical data

		MultiDrive MI 250 (- S)	MultiDrive MI 400 (- S)	MultiDrive MI 250 T (- S)	MultiDrive MI 400 T (- S)
Max. useful volume	ml	250	400	250	400
Grinding tools material		Stainless steel			
Grinding chamber material		Stainless steel			
Standard milling tool diameter	mm	71	81	71	81
Max. circumferential speed	m/s	75	85	75	85
Allowed speed range	rpm	3000 ... 20000 ①			
Max. feed grain size	mm	7 (impact milling) 10 (cutting milling)			
Max. feed hardness	Mohs	5 (with standard beater) 9 (with hard metal beater)		5 (with standard beater)	
Max. operating time	min.	5 ①		30 ①	
Min. cooling time		10		10	
Integrated temperature / RFID sensor		No		Yes	
Min. / Max. temperature limit	°C	-		-50 ... +120 ①	
Temperature measurement		No		Yes	
Temperature measurement resolution	K	-		0.1	
Temperature measurement accuracy	K	-		± 5	
Milling chamber can be cooled with water		Yes			
Cooling circuit temperature	°C	max. + 40 min. -5			
Pressure in cooling circuit	bar	max. 0.5			
Mill feed can be cooled in milling chamber with dry ice		Yes			
Mill feed can be cooled in milling chamber with liquid nitrogen		No			
Maintenance time counter		No		Yes	
Max. maintenance time	h	-		40 ①	
Recommended for drive unit		MultiDrive basic		MultiDrive control	
		MultiDrive control			
FDA conformity		Yes			
Suitable for solvents		NO			
Suitable for abrasive substances		Yes			
Dishwasher cleanable		No			
Permissible ambient temperature	°C	+5 ... +40			
Permissible relative humidity	%	80			
Dimension (W x D x H)	mm	160 x 160 x 180			
Weight	kg	1.5			

① **Note:** The value is limited by the drive unit!

Subject to technical changes!

