

IKA

designed for scientists

IKA RC 2 GREEN basic



Operating instructions

EN

Device setup

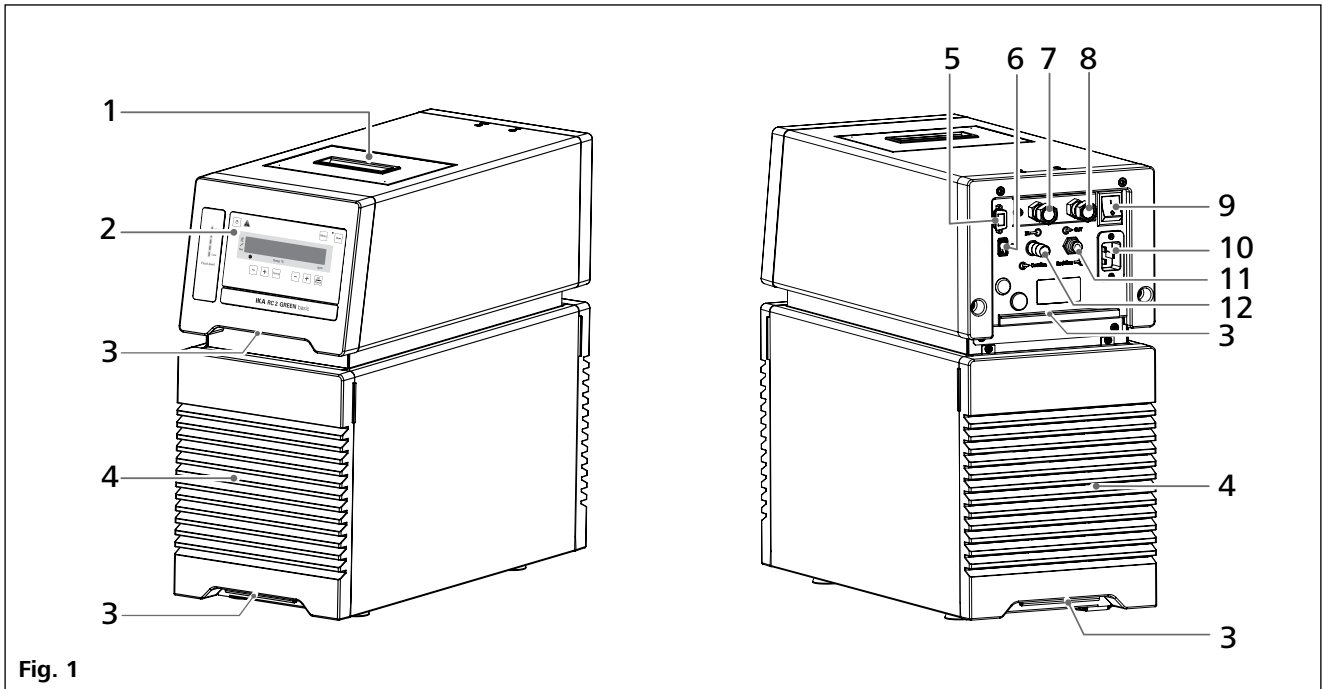

Fig. 1

Item	Designation
1	Filling opening lid
2	Operator panel and display
3	Handle
4	Venting grid
5	RS 232 port
6	USB port
7	Pump connector IN
8	Pump connector OUT
9	Power switch
10	Power socket
11	Backflow
12	Overflow

Contents

	Page
Device setup	2
EC Declaration of Conformity	4
Explication of warning symbols	4
Safety instructions	5
General information.....	5
Fluids.....	6
Refrigerant.....	6
Disposal instructions.....	6
Intended use	7
Use.....	7
Range of use.....	7
Unpacking	7
Unpacking.....	7
Delivery scope.....	7
Preparations	7
Setting up.....	7
Connecting the tubings.....	7
Filling and draining.....	8
Fluid (Standard information for IKA fluid).....	10
Moving the device.....	11
Operator panel and display	11
Commissioning and operating	12
Menu settings	13
Menu structure.....	13
Basic guide to setting the menu options.....	13
Operating mode (MODE).....	13
Maximum temperature (HI T).....	13
Minimum temperature (LO T).....	13
Maximum speed (HI R).....	13
Minimum speed (LO R).....	13
Fluid type (FLUI).....	13
Temperature control type (AUTO).....	14
Alarm and button tone (BEEP).....	14
Calibration (CALI).....	14
Reset to factory settings (RST).....	15
Interface and output	16
Maintenance and cleaning	18
Error codes	19
Accessories	19
Technical data	20
Warranty	21
Pump performance curve	21

EU Declaration of conformity

We declare under our sole responsibility that this product corresponds to the directives 2014/35/EU, 2006/42/EC, 2004/108/EC and 2011/65/EU and conforms with the following standards or normative documents: EN 61010-1, EN 61010-2-011, EN 61326-1, EN 60529, EN ISO 12100 and DIN 12876-1.

A copy of the complete EU Declaration of Conformity or further declarations of conformity can be requested.

Explication of warning symbols



Indicates an (extremely) hazardous situation, which, if not avoided, will result in death, serious injury.



Indicates a hazardous situation, which, if not avoided, can result in death, serious injury.



Indicates a potentially hazardous situation, which, if not avoided, can result in injury.



Indicates practices which, if not avoided, can result in equipment damage.



Indicates the risk of fire or explosion!



Indicates crushing risk to fingers/hand.



Warning: flammable material!

Safety instructions

General information:

- **Read the operating instructions completely before starting up and follow the safety instructions.**
- Keep the operating instructions in a place where it can be accessed by everyone.
- Ensure that only trained staff work with the device.
- Follow the safety instructions, guidelines, occupational health, safety and accident prevention regulations.
- Set up the device in a spacious area on an even, stable, clean, non-slip, dry and fireproof surface.
- The device has been constructed to the requirements of EU (European Union) and EFTA (European Free Trade Association) countries.



DANGER

Do not use the device in explosive atmospheres, it is not EX-protected.

With substances capable of forming an explosive mixture, appropriate safety measures must be applied, e.g. working under a fume hood.

To avoid body injury and property damage, observe the relevant safety and accident prevention measures when processing hazardous materials.

- Protect the device and accessories from bumping and impacting.
- Check the device and accessories for damage before each use. Do not use damaged components.
- Safe operation is only guaranteed with the accessories described in the "Accessories" section.
- The device must only be operated with the original power cord.
- The socket for the power cable must be easily accessible.
- Socket must be earthed (protective ground contact).
- The voltage stated on the type plate must correspond to the power voltage.
- The device can only be disconnected from the power supply by pulling out the power plug or the connector plug.
- Disconnect the power plug before attaching or changing any accessories.
- Disconnect the power plug before cleaning, maintenance and transportation of the unit.
- The device must only be opened by trained specialists, even during repair. The device must be unplugged from the power supply before opening. Live parts inside the device may still be live for some time after unplugging from the power supply.



NOTICE

Coverings or parts that can be removed from the device must be put back on the device again to ensure safe operation, for example to keep foreign objects and liquids, etc. from getting into the device.

- The device may only be used as prescribed and as described in these operating instructions. This includes operation by instructed specialist personnel.
- When using critical or hazardous materials in your processes, **IKA** recommends to use additional appropriate measures to ensure safety in the experiment. For example, users can implement comprehensive monitoring equipment.
- Process pathogenic material only in closed vessels under a suitable fume hood. Please contact **IKA** application support if you have any question.



CAUTION

If the power switch is not within reach when device is operating, an **EMERGENCY STOP** switch that can be easily accessed must be installed in the work area.

- A laboratory circulator refrigerates and circulates fluid according to specified parameters. This involves hazards due to high and low temperatures and general hazards due to the device of electrical energy. The user safety can not be ensured simply with design requirements on the part of the device. Further hazard sources may arise due to the type of tempering fluid, e.g. by exceeding or undercutting certain temperature thresholds or by the breakage of the container and reaction with the carrier fluid. It is not possible to consider all eventualities. They remain largely subject to the judgment and responsibility of the operator. For this reason, it become necessary for user to take other precautionary safety measures.
- Insufficient ventilation may result in the formation of explosive mixtures. Only use the device in well ventilated areas.
- When device is used for external circulation, extra precaution must be taken for cold fluid leakage due to damaged hose.
 - Use suitable hoses for connection.
 - Secure hoses and tubes against slippage and avoid kinks.
 - Check hoses, tubes and bath at regular intervals for possible material fatigue (cracks/leaks).



WARNING

Do not start up the device if:
-It is damaged or leaking
-Cable (not only supply cable) is damaged.

- After a power failure during operation, the device may start automatically (depending on operating mode).



WARNING

Because of the heavy weight of the device, at least two person are needed for carrying the device.

- Transport the device with care (see section "Moving the device").

- Do not transport or empty the bath while it is still cold.
- Always empty the bath before moving the unit.



Always empty the bath if the unit is unused for long time.

Fluids:



Only use the fluids, which fulfill the requirements for safety, health and device compatibility. Be aware of the chemical hazards that may be associated with the bath fluid used. Observe all safety warning for the fluids.

- Depending on the bath fluid used and the type of operation or toxic can arise. Ensure suitable extraction.
- Do not use any fluid which may cause dangerous reactions during processing.
- Only use recommended bath fluid. Only use non-acid and non corroding fluid.



Never operate the device without sufficient fluid! Check the fluid level detection at a regular basis (see the section "Filling and draining").

- Continuous monitoring of the filling level of the bath fluid is required.
- To ensure a sufficient fluid circulation, the viscosity of the bath fluid must not exceed of 50mm²/s at the lowest operating temperature.
- Untreated tap water is not recommended. It is recommended to use distilled water or high purity water (ion exchangers) and add 0.1 g soda (sodium carbonate Na₂CO₃) /liter, to reduce corrosive properties.



Don't use following fluids:

- Untreated tap water
- Acids or bases
- Solutions with halides: chlorides, fluorides, bromides, iodides or sulfur
- Bleach (Sodium Hypochlorite)
- Solution with chromates or chromium salts
- Glycerine
- Ferrous water.

Refrigerant:



The device is not allowed to be used in an ATEX (Atmosphere Explosible) zone.



Flammable refrigerant used. Do not use mechanical devices or other means to accelerate the defrosting process, other than those recommended by the manufacturer.



Do not damage the refrigerant circuit.

- Insufficient ventilation may result in the formation of explosive mixtures. Only use the device in well ventilated areas and keep all air vents open.
- Flammable refrigerant used. Only the manufacturer may open and repair the closed refrigeration system.
- The minimum room size is 9 m³, so that in the event of an error (exit of the complete refrigerant filling quantity) no flammable refrigerant-air mixture can arise (R 290 max. 8 g/m³ ambient air).

Disposal instructions

- The device, accessories and packaging must be disposed of in accordance with local and national regulations.

Intended use

Use:

Use **RC 2 GREEN** (Refrigerated Circulators) for tempering and circulating fluids.

Intended Use: Tabletop device

Range of use:

Indoor environments similar to that a laboratory of research, teaching, trade or industry.

The safety of the user cannot be guaranteed:

- If the device is operated with accessories that are not supplied or recommended by **IKA**.
- If the device is operated improperly or in contrary to the **IKA** specifications.
- If the device or the printed circuit board are modified by third parties.

Unpacking

Unpacking:

- Unpack the device carefully.
- Any damage should be notified immediately to the shipping agent (post office, railway network or logistics company).

Delivery scope:

- **RC 2 GREEN basic**
- Power cables
- Hose olive NW 8 (2 pieces)
- Hose olive NW 12 (2 pieces)
- Plastic cap (for "**Overflow**" connector)
- Plastic cap (for "**Backflow**" connector)
- USB 2.0 cable (A-micro B)
- User guide
- Warranty card.

Preparations

Setting up:

- Place the unit on an even, stable, clean, nonslip, dry and fireproof surface.
- Keep at least 20 cm of open space on the front and rear side.
- The place for installation should be large enough and provide sufficient air ventilation to ensure the room does not warm up excessively because of the heat from device radiates to the environment.
- Do not set up the device in the immediate vicinity of heat sources and do not expose to sun light.
- Cooling machine, pump motor and electronics produce intrinsic heat that is dissipated via the venting grids (4)! Never cover these venting grids!

Note: After setting up the device, wait at least one hour before starting the operation to avoid the damage to the cooling system.

Connecting the tubings:

- Unscrew the union nuts and stoppers using a wrench (AF 19) from the pump connector **IN** (7) and **OUT** (8).

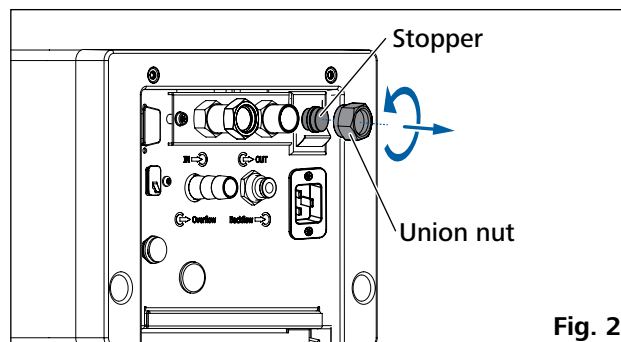

- Connect the hoses for circulating the external system to the pump connectors M 16 x 1 for **IN** and **OUT** directly or with the olives.

- Screw the hose olive to the pump connection **IN** and **OUT** with union nuts. Slide the hoses (NW 12) onto the olives. The hoses must be secured with suitable clamps.

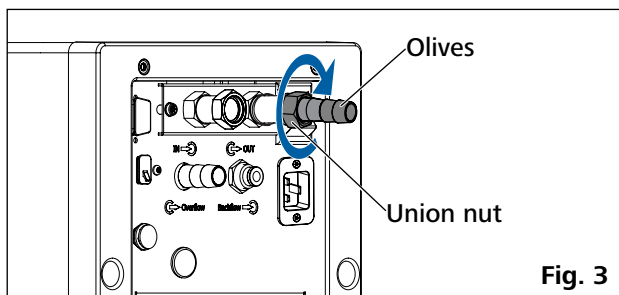

Fig. 3

- Via a hose to the “**Overflow**” connection (12), overflowing fluid can be directed into a suitable vessel. The vessel should be positioned lower than the “**Overflow**” connection. In case of closed external system, if there is in any case no risk of exceeding the maximum fluid level, you can close the “**Overflow**” connector with the included overflow cap. This minimizes the energy loss and protects, in case of long-term applications with low temperatures and high humidity, against unwanted water input and the associated volume increase. Check fluid heat expansion!
- Connect the “**Backflow**” connector (11) to **IKA** calorimeter with a suitable hose. When **IKA** calorimeter is not connected, please close the “**Backflow**” connector with included backflow cap.

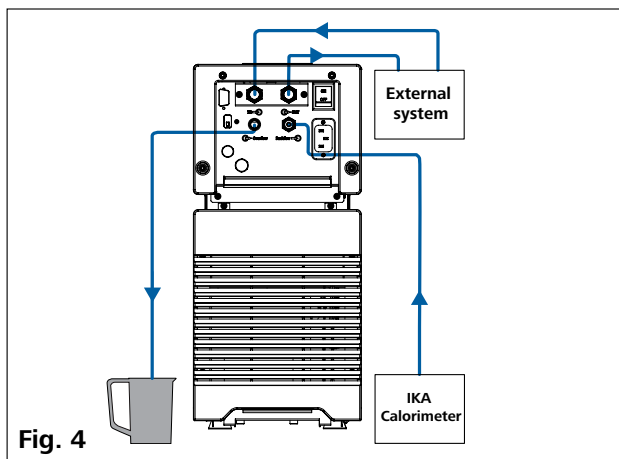

Fig. 4

Note: When the external system is not necessary, please seal the pump connector **IN** and **OUT** with the existing union nuts and stoppers.

Filling and draining:

- Before filling the fluid into the bath, open the venting grid as indicated in following figure.

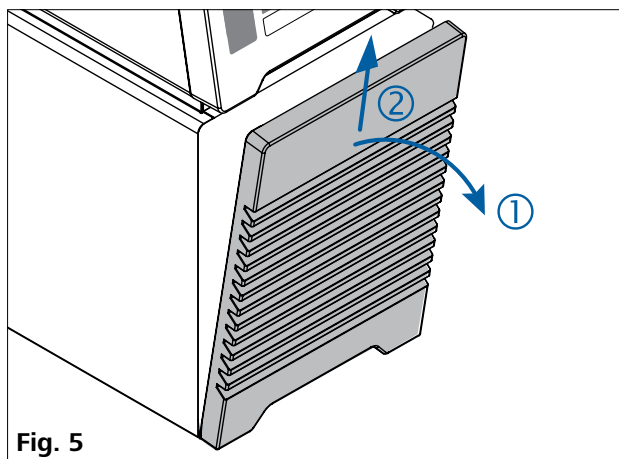

Fig. 5

- Check and make sure that the drain valve is closed (rotate clockwise to the stop position, see Fig. 6).

Note: Please note information in section “Commissioning and operating”.

- Connect the power plug and turn on the device with power switch.
- The low level warning message appear on the display. Meanwhile, the bottom LED segment of fluid level indicator lights up in red color to indicate the low fluid level (see Fig. 7).
- Open the filling opening lid and remove the stopper from the filling opening. Then, fill fluid to the bath.

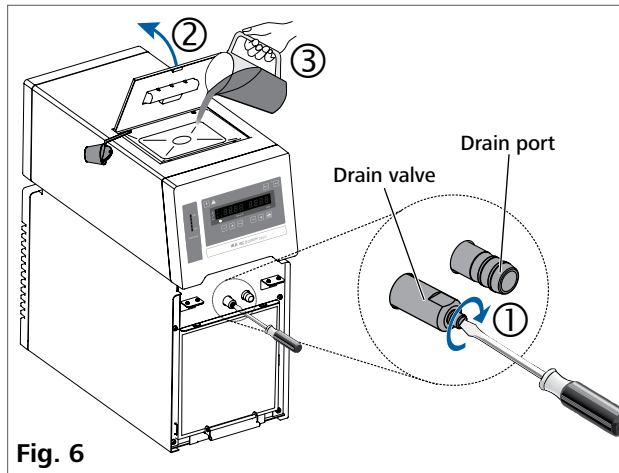

Fig. 6

Note: Pay attention to the fluid level information!



Low Level



High Level

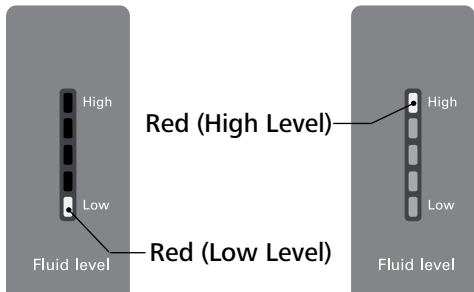

Fig. 7

- To drain the fluid from the bath, connect a hose to the drain port and turn the drain valve in counter clockwise direction with a straight screwdriver.

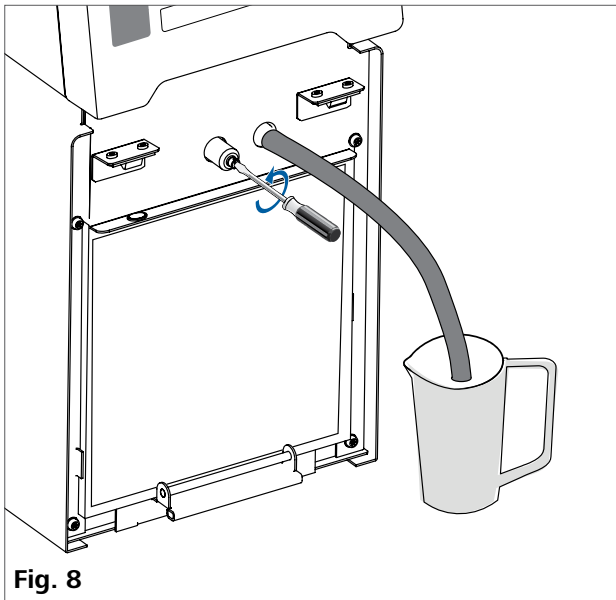

Fig. 8

Warning: Do not empty the bath while the fluid is still cold, there is a risk of freezing.

Fluids (Standard information for IKA fluid):

No.	IKA Designation	Operating temperature range for open bath application (°C)	Operating temperature range for closed bath applications (°C)	Safety temperature (°C)	Flash point (°C)
0	CF.EG28.N10.80.8	-10 ... 80	-10 ... 80	90	115
1	CF.EG39.N20.80.16	-20 ... 80	-20 ... 80	90	115
2	CF.EG44.N25.80.19	-25 ... 80	-25 ... 80	90	115
3	CF.EG48.N30.80.22	-30 ... 80	-30 ... 80	90	115
4	UF.Si.N30.150.10LV	-30 ... 130	-30 ... 150	145 ❶	> 170
5	HF.Si.20.200.50	20 ... 200	20 ... 200	255	> 280
6	HF.Si.20.250.50A	20 ... 200	20 ... 250	255	> 280
7	Water ❷	5 ... 95	5 ... 95	-	-
8	Customized ❸				

The listed fluid temperature range may deviate from the device operating temperature ranges and settings.

Nomenclature for IKA fluids:

CF.EG28.N10.80.8 --

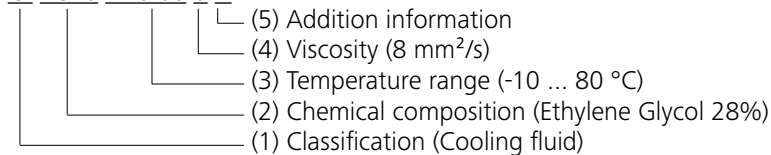

(1) Classification:

HF: Heating Fluid
 CF: Cooling Fluid
 UF: Universal Fluid

(2) Chemical composition:

Si: Silicone oil
 EG: Ethylene Glycol

(3) Temperature range: (Minimum temperature. Maximum temperature)

N: Negative Temperature

(4) Viscosity:

Viscosity at 25 °C for Heating Fluid (HF)
 Viscosity at -20 °C for Cooling Fluid (CF)
 Viscosity at 25 °C for Universal Fluid (UF)

Dynamic viscosity [mPa•s] is a product of kinematic viscosity [mm²/s] and density [kg/m³] of the fluid divided by 1000.

(5) Additional information:

A: Oil Additives
 LV: Low Viscosity

❶ **Note:** for open bath application!

❷ **Note:** Tap water may be unsuitable for operation because the calcium carbonate content may cause calcification.

High purity water (from ion exchangers) and distilled or bi-distilled water are unsuitable for operation due to corrosive properties of these media. High purity water and distillates are suitable as a medium after adding 0.1 g soda (Na₂CO₃, sodium carbonate) per liter of water.

❸ **Note:** The temperature limit values are adjustable in accordance with the fluid used.

Moving the device:

Empty all fluid in the bath before moving device from one place to other place.

The device must be lifted by two persons with the upper handles.

It can also be moved on flat surface by lifting and pushing the front of the device. It is easy to move the device with the help of the wheels.

The angle of inclination should never be more than 10 ° at any direction when move the device!

Note: The device must not be moved during operation. After moving the device, you must wait at least one hour before restarting the unit.

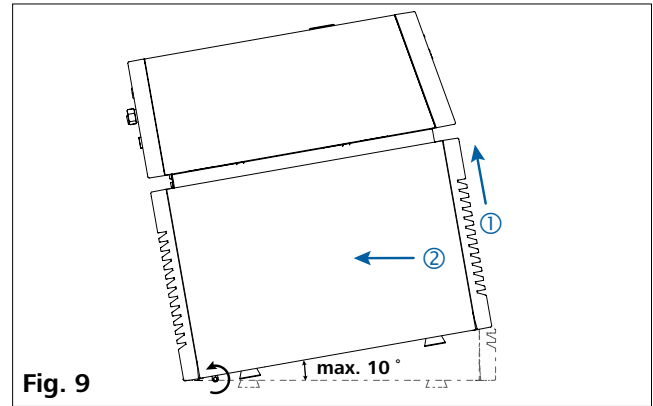

Fig. 9

Operator panel and display

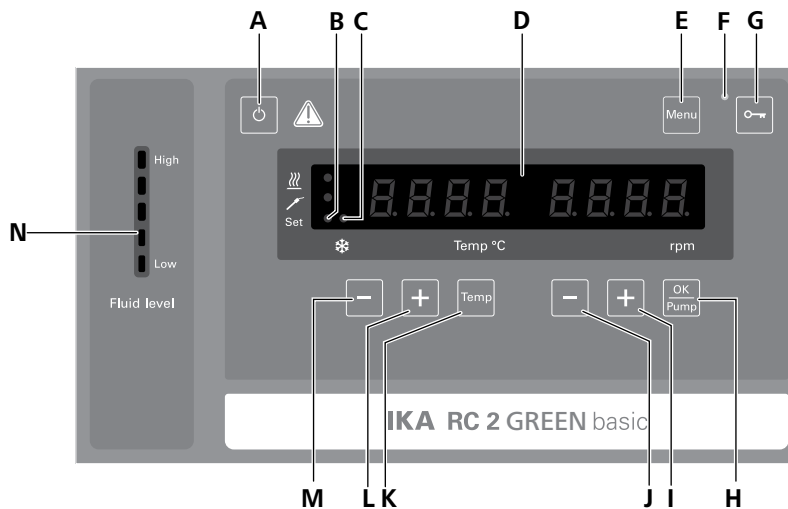

Fig. 10

Item	Designation	Function
A	On/Off button:	Switch on/off the circulator.
B	LED, set:	The LED lights up at the same time as the set value is displayed.
C	LED, cooling:	The LED indicates the refrigerating function is activated.
D	LED display:	Display the settings and actual values.
E	"Menu" button:	Press it once: menu option is display. Press it once again: back to working screen.
F	LED, lock:	Indicate the buttons are deactivated.
G	Lock button:	Lock/unlock buttons.
H	"OK / Pump" button:	Start/stop the pump function. Confirm the menu options.
I	"Pump (+)" button:	Increase the pump speed setting.
J	"Pump (-)" button:	Decrease the pump speed setting.
K	"Temp" button:	Change the menu value setting.
L	"Temp (+)" button:	Decrease the temperature setting.
M	"Temp (-)" button:	Increase the temperature setting.
N	Fluid level indicator:	Navigation, selecting the settings in the menu. Indicate the fluid level (when the fluid level is too low or too high, the bottom or the top LED segment change into red color).

Commissioning and operating

Note: Before commissioning, make sure that the device has not been moved in one hour.

Check whether the voltage specified on the type plate matches the power voltage available.

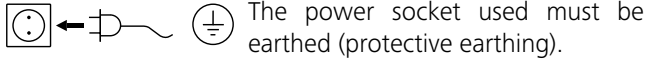

If above conditions are met, the instrument is ready for operation after plugging in the power plug.

If these conditions are not met, safe operation is not guaranteed and the device could be damaged.

Observe the ambient conditions (temperature, humidity, etc.) listed under "Technical Data".

After switching on the power switch (9) at the back of the device or pressing the on/off button (A), all LED segments light up during the self test.



① Display field



② Software version (ver)



③ Operating mode (mode)



④ Working setting

After that, following two screens appear alternately.



Then the device enters standby status and is ready for operation.

Change the temperature setting with "Temp (+)" button (L) or "Temp (-)" button (M).

Change the pump speed setting with "Pump (+)" button (I) or "Pump (-)" button (J).

In standby status, activate the tempering function by pressing the "Temp" button (K). The pump and fan starts to run at once. The refrigerating function may delay to start about 2 minutes.

In working status, press the "OK/Pump" button (H) to stop pumping and tempering function.

Note: In running status, the pump speed adjusts automatically according to the load. When the actual speed doesn't reach the setting speed, the blinking set speed and the actual speed appears alternately.

In standby status, press the "OK/Pump" button (H) to start the pump function. The tempering function will not be activated.

In working status, press the "Temp" button (K) to stop the re tempering function, the pump keep running.

Pressing the lock button (G) for about 2 seconds, the device control elements can be locked to prevent accidental changes that can be done during operation (LED (F) will light up). To unlock the control elements, press the lock button again for about 2 seconds (LED (F) goes out).

Menu settings

Menu structure:

		Default settings
Menu	MODE	A ----- Activated
		B ----- -
		C ----- -
	Maximum temperature (HI T) -----	40 °C
	Minimum temperature (LO T) -----	- 30 °C
	Maximum speed (HI R) -----	4000 rpm
	Minimum speed (LO R) -----	2000 rpm
	Fluid type (FLUI) -----	8
	The type of temperature PID control arithmetic (AUTO)	AUTO 1 ----- Activated
		AUTO 0 -----
		Proportional coefficient of PID (Kp 1) -- 60.0
		Integrate time of PID (Ti 1) ----- 5.00
		Differential time of PID (Td 1) ----- 0.3
	Alarm and button tone (BEEP)	BEEP 0 ----- -
		BEEP 1 ----- Activated
Calibration (CALI)	CALI 0 ----- Activated	
	CALI 2 ----- -	
	CALI 3 ----- -	
Reset to factory settings (RST)	No ----- Activated	
	Yes ----- -	

Basic guide to setting the menu options:

- ☞ Enter the menu by pressing "Menu" button (E).
- ☞ Press the "Temp (+)" button (L) or "Temp (-)" button (M) to change the menu options.
- ☞ Press the "Pump (+)" button (I) or "Pump (-)" button (J) to change the menu value settings.
- ☞ Confirm the menu settings by pressing the "OK/Pump" key (H).

Operating mode (MODE):



Mode A: After power on/power failure no automatic restart of functions.

Mode B: After power on/power failure automatic restart of functions, depending on previous settings.

Mode C: Set values (set in mode A or B) cannot be changed. After power on/power failure automatic restart of functions, depending on previous settings.

Maximum temperature (HI T):



The maximum adjustable value: 40 °C.

Minimum temperature (LO T):



The minimum adjustable value: - 30 °C.

Maximum speed (HI R):



The maximum adjustable value: 4000 rpm.

Minimum speed (LO R):



The minimum adjustable value: 2000 rpm.

Fluid type (FLUI):



The chosen fluid (No.) limits the maximum and minimum temperature. Customized fluid (No.: 8) enables the whole working temperature range. See Section "Fluids (Standard information for IKA fluid)".

Temperature control type (AUTO):



AUTO 1:

AUTO 1 is the default setting. The default PID settings are used automatically.

Cooling down curve in AUTO 1 control (AUTO 1):

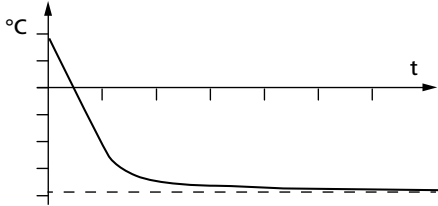

Fig. 11

AUTO 0:

For special requirements, AUTO 0 can be used with manual adjustment of the control parameters.

If the PID control (AUTO 0) option is selected, the following items including **Kp 1**, **Ti 1** and **Td 1** could be set. Otherwise they are not displayed in the menu list.

Note: Inappropriate settings may produce the following cooling down curves:

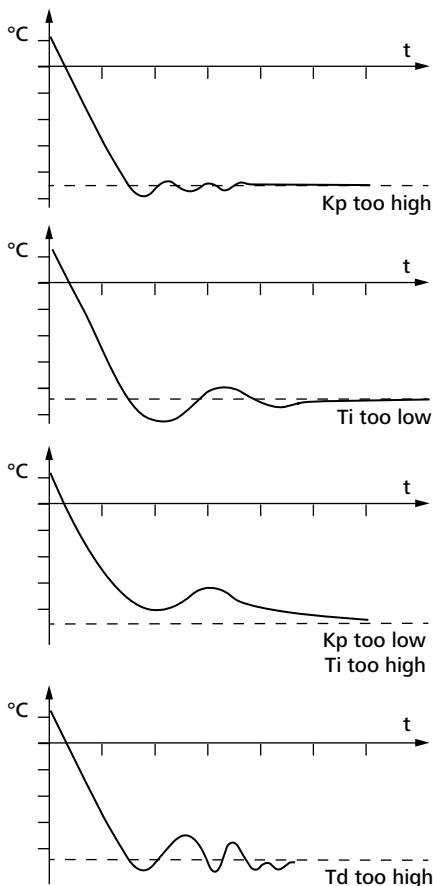

Fig. 12

Proportional coefficient of PID (**Kp 1**)



The proportional coefficient **Kp** is the controller amplification and determines how strongly the control deviation (the difference between the target temperature and actual temperature) directly affects the control variable (cooling down time). **Kp** values that are too large can lead to the controller overshooting.

Integral time of PID (**Ti 1**)



The integral time **Ti (s)** is the correction time and determines how strongly the duration of the control deviation affects the control variable. **Ti** compensates an existing control deviation. A high **Ti** means a smaller and slower effect on the control variable. **Ti** values that are too small can lead to instability of the controller.

Differential time of PID (**Td 1**)



The differential time **Td (s)** is the derivative time and determines how strongly the rate of change of the control deviation affects the control variable. **Td** compensates for rapid control deviations. A high **Td** means a smaller and slower effect on the control variable. **Td** values that are too small can lead to instability of the controller.

Alarm and button tone (**BEEP**):



BEEP 0: no alarm and button tone

BEEP 1: alarm and button tone is activated

Calibration and adjustment (**CALI**):



CALI 0: Reset calibration

CALI 2: 2-point calibration

CALI 3: 3-point calibration

Example: 2-point calibration:

Dip the temperature sensor of the reference measuring instrument into the bath fluid.

Select 2-point calibration in the menu. Press the "OK/Pump" button (H) to start the 2-point calibration.



Set the first point temperature (step 1, e.g. 10 °C) with "Pump (+)" button (I) or "Pump (-)" button (J). Confirm the setting by pressing "OK/Pump" button (H).



Left area of the display appears the set value (10 °C) and the right area of the display appears the actual temperature value measured. The "Set" LED (B) flashes briefly.



The unit now starts and controls to the set value. When the temperature has reached the set value and has become constant, the "Set" LED (B) no longer flashes and the following display appears. The temperature measured by the unit appears on the left hand side.



Input the calibration value from the reference measuring instrument (e.g. 10.1 °C) with "Pump (+)" button (I) or "Pump (-)" button (J).



Confirm the value by pressing the "OK/Pump" button (H). Back to previous screen for input a new value by pressing "Temp" button (K).

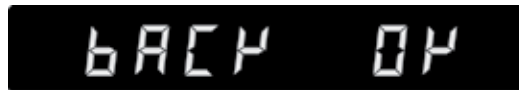

Back

OK

The first point calibration is finished now. Calibration of the other points is performed in the same way.

Reset to factory settings (RST):



RST (No): Without resetting to factory settings.



RST (Yes): Resetting to factory settings.

Interface and output

The device can be operated in "Remote" mode via the RS 232 port (5) or the USB port (6) connected to a PC and with the laboratory software Labworldsoft®.

Note: Please observe the system requirements together with the operating instructions and help section included with the software.

USB interface:

The Universal Serial Bus (USB) is a serial bus for connecting the device to the PC. Equipped with USB devices can be connected to a PC during operation (hot plugging). Connected devices and their properties are automatically recognized. The USB port can also be used to update firmware.

USB device driver:

First, download the latest driver for **IKA** devices with USB port.

Install the driver by running the setup file. Then connect the **IKA** device through the USB data cable to the PC.

The data communication is via a virtual COM port. Configuration, command syntax and commands of the virtual COM ports are as described in RS 232 interface.

Device software update:

For device software update, visit **IKA** website and enter the "Service" menu. Download and run the Firmware Update Tool.

Find and click the Firmware Update Tool in your PC after installation. Register your E-mail and password.

Connect the device to your PC via the USB cable. Then, you can update the device software according to instructions of the Firmware Update Tool.

RS 232 interface:

Configuration:

- The functions of the interface connections between the device and the automation system are chosen from the signals specified in EIA standard RS 232 in accordance with DIN 66 020 Part 1.
- For the electrical characteristics of the interface and the allocation of signal status, standard RS 232 applies in accordance with DIN 66 259 Part 1.
- Transmission procedure: asynchronous character transmission in start-stop mode.
- Type of transmission: full duplex.
- Character format: character representation in accordance with data format in DIN 66 022 for start-stop mode. 1 start bit; 7 character bits; 1 parity bit (even); 1 stop bit.
- Transmission speed: 9600 bit/s.
- Data flow control: none
- Access procedure: data transfer from the device to the computer takes place only at the computer's request.

Command syntax and format:

The following applies to the command set:

- Commands are generally sent from the computer (Master) to the device (Slave).
- The device sends only at the computer's request. Even fault indications cannot be sent spontaneously from the device to the computer (automation system).
- Commands are transmitted in capital letters.
- Commands and parameters including successive parameters are separated by at least one space (Code: hex 0x20).
- Each individual command (incl. parameters and data) and each response are terminated with CR LF (Code: hex 0x0D hex 0x0A) and have a maximum length of 80 characters.
- The decimal separator in a number is a dot (Code: hex 0x2E).

The above details correspond as far as possible to the recommendations of the NAMUR working party (NAMUR recommendations for the design of electrical plug connections for analogue and digital signal transmission on individual items of laboratory control equipment, rev. 1.1).

The NAMUR commands and the additional specific **IKA** commands serve only as low level commands for communication between the device and the PC. With a suitable terminal or communications programme these commands can be transmitted directly to the circulator equipment. The **IKA** software package, Labworldsoft®, provides a convenient tool for controlling circulating equipment and collecting data under MS Windows, and includes graphical entry features, for pump motor speed ramps for example.

Commands:

NAMUR Commands	Function
IN_PV_2	Read the internal actual temperature
IN_PV_4	Read the pump actual speed
IN_SP_1	Read the internal setting temperature
IN_SP_4	Read the pump setting speed
OUT_SP_1 xxx	Set the internal setting temperature XXX
OUT_SP_12@n	Set the WD safety temperature with echo of the set (defined) value.
OUT_SP_4 xxx	Set the pump speed XXX
OUT_SP_42@n	Set the WD-safety speed with echo of the set (defined) value.
OUT_WD1@n	Start the watchdog mode 1 and set the time for the watchdog to n (20...1500) seconds. Echo of the Watchdog time. During a WD1-event, the tempering and pump functions are switched off. This command needs to be send within the watchdog time.
OUT_WD2@n	Start the watchdog mode 2 and set the watchdog time to n (20...1500) seconds. Echo of the watchdog time. During a WD2-event, the set temperature is changed to the WD safety temperature and the pump set speed is set to the WD safety speed. This command needs to be send within the watchdog time.
RESET	Reset the PC control and stop the device functions.
START_1	Start the tempering function.
START_4	Start the pump function.
STOP_1	Stop the tempering function.
STOP_4	Stop the pump function.

Connections between device and external devices:

PC 1.1 Cable:

This cable is required to connect RS 232 interface (5) to a PC.

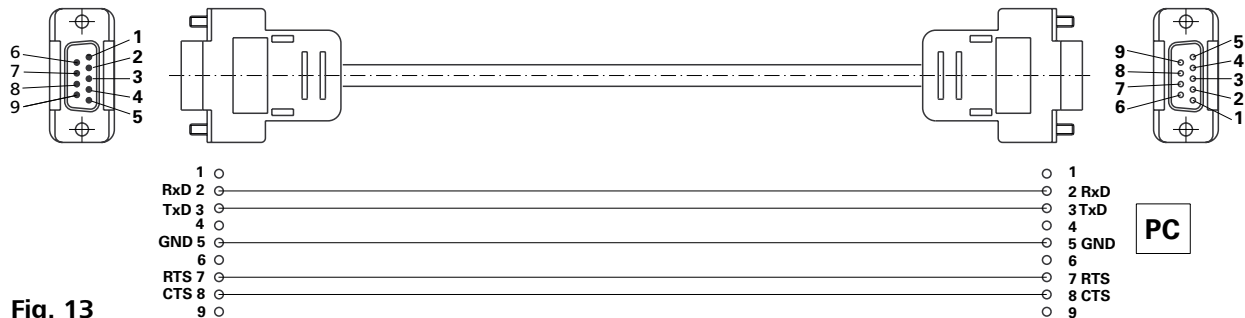
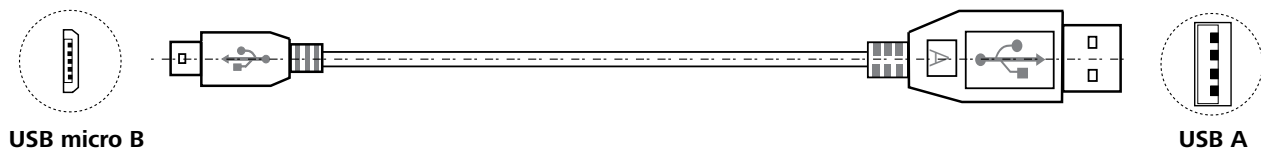

Fig. 13

USB 2.0 cable A - micro B:

This cable is required to connect USB interface (6) to a PC.



USB micro B
Fig. 14

Maintenance and cleaning

To avoid contamination, it is essential to change the bath fluid regularly.

If water is used for bath fluid, we recommend to add Water bath protective media. The protective media stops the growth of algae, bacteria and other microorganisms.

To keep the full cooling performance, the dust filter of the cooler must be checked regularly and cleaned if necessary.

- Switch off the device and disconnect power cable.
- Open the front venting grid.
- Take out the dust filter.
- Clean condenser dust protection sheet with a vacuum cleaner or wash the sheet in the water and dry the sheet before assembly.

Note: Don't touch the condenser surface with hard parts.

Cleaning:

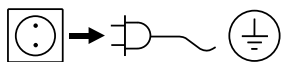

Disconnect main plug prior to cleaning!

Use only cleaning agents which have been approved by **IKA** to clean the device: Water containing surfactant / isopropyl alcohol.

- Wear protective gloves while cleaning the devices.
- Electrical devices may not be placed in the cleansing agent for the purpose of cleaning.
- Do not allow moisture to get into the device when cleaning.
- If a different cleaning or decontamination method than the method defined by **IKA** is planned, the user must ascertain with **IKA** that this method does not damage the device.

Spare parts order:

When ordering spare parts, please give:

- machine type
- manufacturing number, see type plate
- item and designation of the spare parts
- software version.

Repair:

Please send in device for repair only after it has been cleaned and is free from any materials which may constitute a health hazard.

For repair, please request the "Decontamination Clearance Certificate" from **IKA**, or download printout of it from the **IKA** website.

If you require servicing, return the device in its original packaging. Storage packaging is not sufficient. Please also use suitable transport packaging.

Error codes

Any malfunctions during operation will be identified by an error message on the display.

Proceed as follows in such cases:

- ☞ Switch off device using the main switch at the back of the device
- ☞ Carry out corrective measures
- ☞ Restart device

Error code	Effect	Cause	Solution
Err 02	Pump off Refrigerating off	Motor over current (rate current)	- Reduce pump motor speed - Use fluid with lower viscosity - Check if the pump impeller is blocked
Err 04	Pump off Refrigerating off	Motor hall signal missing	- Reduce pump motor speed - Use fluid with lower viscosity - Check if the pump impeller is blocked
Err 06	Pump off Refrigerating off	Too low liquid level	- Check the fluid level and buoyage
Err 15	Pump off Refrigerating off	Compressor power supply disconnected	- Restart the device
Err 16	Pump off Refrigerating off	Suction temperature error	- Restart the device
Err 17	Pump off Refrigerating off	Discharge temperature error	- Restart the device
Err 19	Pump off Refrigerating off	Fluid temperature too high	- Switch the device off and let the fluid cool down
Err 20	Pump off Refrigerating off	Fan cooling system error	- Restart the device

If the actions described fails to resolve the fault or another error code is displayed then take one of the following steps:

- Contact the service department
- Send the device for repair, including a short description of the fault.

Accessories

Tubing and hoses:

LT 5.20	Metal hose (isolated M16 x 1)
LT 5.21	PTFE hose (isolated M16 x 1)
H.PVC.8	PVC tube (nominal width 8 mm)
H.PVC.12	PVC tube (nominal width 12 mm)
H.SI.8	Silicone tube (nominal width 8 mm)
H.SI.12	Silicone tube (nominal width 12 mm)
H.PUR.8	PUR tube (nominal width 8 mm)
H.PUR.12	PUR tube (nominal width 12 mm)
H.FKM.8	FKM tube (nominal width 8 mm)
H.FKM.12	FKM tube (nominal width 12 mm)

Tubing insulations:

ISO. 8	Insulation (8 mm)
ISO.12	Insulation (12 mm)

Additional accessories:

PC 1.1	Cable (RS 232)
---------------	----------------

Labworldsoft®

See more accessories on www.imlab.eu

Technical data

Operating voltage	VAC	230 ± 10 % 100 ... 115 ± 10 %
Frequency	Hz	50 / 60
Max. input power	W	350
Working temperature range	°C	- 30 ... + RT
Operating temperature range (with external heating)	°C	- 30 ... + 70
Temperature stability – internal temperature control, water (according to DIN 12876)	K	± 0.15
Temperature control		PID
Temperature measurement, absolute accuracy	K	± 0.5
Temperature setting		Button
Temperature setting resolution	K	0.1
Temperature display		LED
Temperature display resolution	K	0.1
Cooling capacity according to DIN 12876 (at 4000 rpm)	W	
+ 20 °C		800
+ 10 °C		700
0 °C		500
- 10 °C		400
- 20 °C		200
- 30 °C	90	
Refrigerant		R 290 !
Refrigerant quantity	g	69
Max. refrigerating system pressure	bar	21
Pump speed (adjustable)	rpm	2000 ... 4000
Max. pump pressure/suction	bar	0.5 / 0.25
Max. flow rate (at 0 bar)	l/min	21
Bath volume	l	1.4 ... 4.0
Fluid maximum viscosity	mm²/s	50
Low fluid level protection		Yes
Interface		USB, RS 232
Permitted on-time	%	100
IP code according to EN 60 529		IP 21
Protection class		I
Excess voltage category		II
Contamination level		2
Permitted ambient temperature	°C	+ 5 ... + 32
Permitted ambient humidity	%	80
Dimension (W x D x H)	mm	220 x 525 x 475
Weight	kg	25.5
Operation at a terrestrial altitude	m	max. 2000

! **Note:** Refrigerant must be disposed of in accordance with local and national regulations.

Subject to technical changes!

Warranty

In accordance with **IKA** warranty conditions, the warranty period is 24 months. For claims under the warranty please contact your local dealer. You may also send the machine direct to our factory, enclosing the delivery invoice and giving reasons for the claim. You will be liable for freight costs.

The warranty does not cover worn out parts, nor does it apply to faults resulting from improper use, insufficient care or maintenance not carried out in accordance with the instructions in this operating manual.

Pump performance curve

Pump performance curve measured with water:

(Measurements done according DIN 12876-2 with water at 20 °C; pump in a closed-loop circuit).

