

IKA

designed for scientists

EN



MEASURING VISCOSITY | IKA ROTAVISC

imLab



www.imlab.eu - info@imlab.eu



+33(0)3 20 55 19 11



+32(0)16 73 55 72

Stepless measurement of viscosities

/// The IKA workflow - now including viscosity measurement

You have been manufacturing, stirring and shaking with IKA laboratory devices for a long time. Thanks to the ROTAVISC series, you can now process your samples with the proven IKA laboratory device structure right up to the viscosity measurement stage. And we're taking a significant step forward here: With the four ROTAVISC models, you measure steplessly from 0,01 to 200 rotations per minute. There's no need to get used to something new. We'll install your new viscometer exactly where you want it. In addition, the measuring process is intuitive, standardized and complies with the familiar IKA menu structure for laboratory devices.

Simply switch it on and start measuring!

10 YEARS
WARRANTY*



Innovative Viscometer Portfolio

Four devices for four viscosity ranges - but a single, huge functional scope for all: IKA ROTAVISC lo-vi, me-vi, hi-vi I, and hi-vi II precisely and reliably determine the flow curves of your fluids.

Personalized Application Advice

You can test all of the viscometers yourself at the IKA Application Center. Our experts will analyze your measuring processes and work with you to find out how best to determine the viscosity of your samples.

Worldwide Service

To opt for an IKA viscometer is also to opt for the excellent IKA technical service in your region. Our team is available worldwide for your service and application needs. Spare parts for your viscometer are guaranteed for 10 years.

10 years
warranty*

CE



IKA ROTAVISC

/// with the largest range of functions in its class

The ROTAVISC series determines the liquid viscosity in all areas of application ranging from the laboratory to quality control. The four devices measure in different viscosity ranges. Regardless of a simple or demanding viscosity measurement – the ROTAVISC delivers rapid and accurate results. The scope of delivery includes an ISO standard spindle set, a protective bracket, temperature sensor and stand system.

The ROTAVISC HELI devices include both a viscometer and the motorized stand IKA HELISTAND.

The new ROTAVISC SBS devices are equipped with a steel ball bearing technology instead of the classic jewel bearing. This makes them very robust.

4

/// FEATURES

11

/// PERIPHERALS

6

/// VISCOSITY MEASUREMENT
AS USUAL. BUT BETTER.

14

/// ACCESSORIES

9

/// PACKAGES

20

/// GOOD TO KNOW

10

/// TECHNICAL DATA

22

/// INDUSTRIES

23

/// FAQ

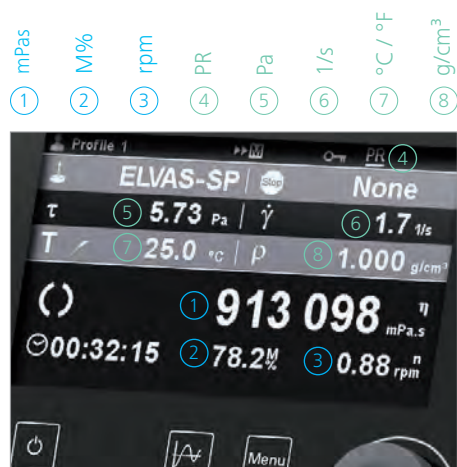

Features

Parameters / Display

The display shows the following parameters:

- ① viscosity
- ② torque
- ③ rotational speed
- ④ program status
- ⑤ shear stress
- ⑥ shear rate
- ⑦ temperature
- ⑧ density

Temperature sensor

The temperature sensor is always included in the scope of delivery, because it is recommended to measure the viscosity in relation to a temperature value.

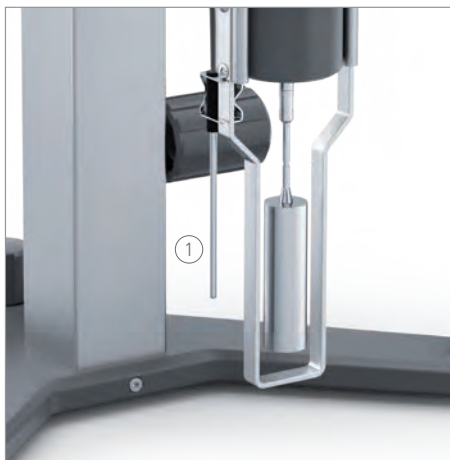

Temperature control

By using suitable accessories it is possible to measure samples from -100 °C to 300 °C.

Stepless positioning

The ROTASTAND ensures perpendicular stability. The height of the viscometer can be adjusted steplessly.

The motorized HELISTAND allows you to measure the viscosity of highly viscous samples with a high level of reliability. It moves the mounted viscometer and its rotating body slowly and uniformly up and down in the sample.

Multiple mountings

Thread adaption, quick connector or hook connector: You attach the spindle to the device in the way that you find most convenient.





3 measuring modes

Three measuring modes are available for different applications: accurate, balance and fast. Ten different programs and ramps can be stored.

Functions

The starting and stopping of a measurement can be defined individually: With a timer, once a certain torque has been achieved, or once the viscosity has been measured. Labworldsoft® enables any number of program and data recordings.

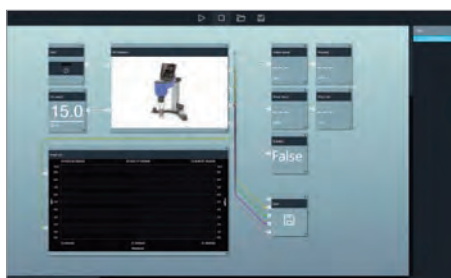

Interfaces

There are connection possibilities available for USB and RS 232. This means that control via a PC and data capture are possible.



Printing

Via the RS 232 port printing of results is possible with serial interface printers. You can print either single reports or continuously.

Spindles

Four spindles are included in the delivery of ROTAVISC lo-vi; six spindles are included in the me-vi and hi-vi packages.

The HELISTAND packages additionally include a set of six T-spindles for non-flowing samples.

Viscosity measurement as usual. But better.



OPERATE THE DEVICE INTUITIVELY ON THE 4,3" TFT DISPLAY.

The large color display offers multilingual menu guidance that is as intuitive as for all other IKA devices.

YOUR ADVANTAGE: The tried-and-tested IKA laboratory device structure is now available for your viscometer too.

PRECISE RESULTS FROM 0,01 – 200 RPM

The accuracy lies at +/- 1% of the maximum value of the measurement range. The reproducibility is +/- 0,2%.

YOUR ADVANTAGE: You get results of highest accuracy.

TAKE STEPLESS MEASUREMENTS

The rotation rate can be set steplessly over the entire measurement range. This allows the stepless programming of a flow curve.

YOUR ADVANTAGE: The only seamless viscosity measurement offered by entry-level viscometers.

EASY SET UP

Delivered in a practical transport case: The viscometer is secured to the ROTASTAND or HELISTAND in no time at all.

YOUR ADVANTAGE: Immediately ready to use - even in different locations.

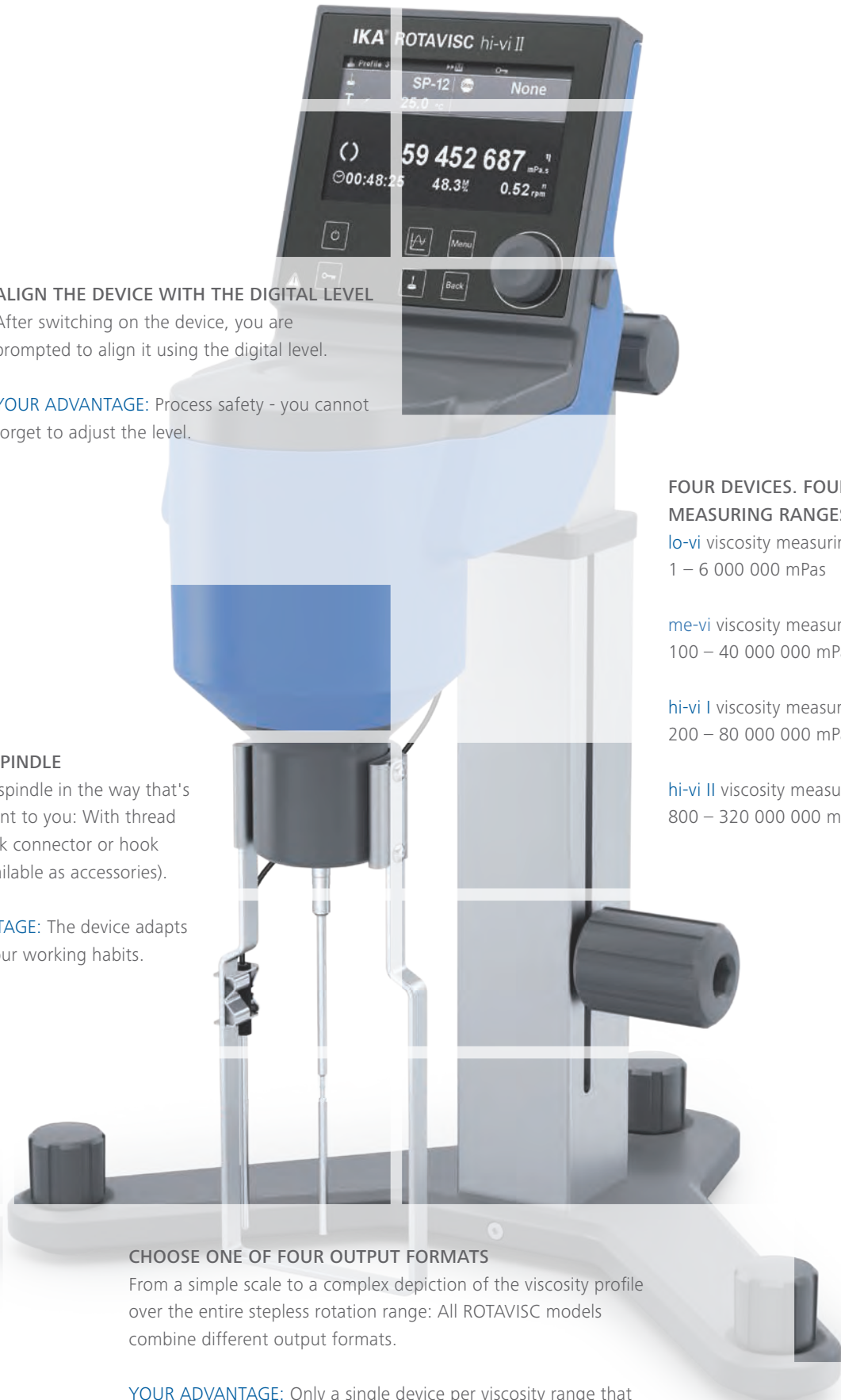

ALIGN THE DEVICE WITH THE DIGITAL LEVEL

After switching on the device, you are prompted to align it using the digital level.

YOUR ADVANTAGE: Process safety - you cannot forget to adjust the level.

FOUR DEVICES. FOUR MEASURING RANGES.

lo-vi viscosity measuring range:
1 – 6 000 000 mPas

me-vi viscosity measuring range:
100 – 40 000 000 mPas

hi-vi I viscosity measuring range:
200 – 80 000 000 mPas

hi-vi II viscosity measuring range:
800 – 320 000 000 mPas

INSERT THE SPINDLE

Insert the ISO spindle in the way that's most convenient to you: With thread adaption, quick connector or hook connector (available as accessories).

YOUR ADVANTAGE: The device adapts itself to suit your working habits.

CHOOSE ONE OF FOUR OUTPUT FORMATS

From a simple scale to a complex depiction of the viscosity profile over the entire stepless rotation range: All ROTAVISC models combine different output formats.

YOUR ADVANTAGE: Only a single device per viscosity range that can deliver all output formats.

ROTAVISC SBS. The viscometer with ball bearing.



AVAILABLE AS COMPLETE AND HELI PACKAGES

NEW BALL-BEARING TECHNOLOGY

The ROTAVISC SBS viscometer complements our ROTAVISC series: In these instruments, a robust ball bearing (Steel Ball Bearing Suspending) replaces the classic jewel bearing. The operation corresponds to the well-known user-friendly principle of the entire ROTAVISC series.

MEASURING RANGES

SBS me-vi viscosity measuring range:
100 – 40 000 000 mPas

SBS hi-vi I viscosity measuring range:
200 – 80 000 000 mPas

SBS hi-vi II viscosity measuring range:
800 – 320 000 000 mPas

COMBINE AND UPGRADE

In the SBS variant, the ROTAVISC me-vi, hi-vi I and hi-vi II viscometer models are now available as Complete and HELI Packages. Do you have a viscometer with jewel bearings? Then we can upgrade it to a ball bearing model if requested. Only ROTAVISC lo-vi for the low viscosity range will continue to be manufactured only with jewel bearings.

FOR HEAVY USE

This ball bearing cannot be overused at all. When changing the spindle, you also no longer have to lift the coupling shaft.

WE RECOMMEND A VISCOMETER IN THE SBS VARIANT ESPECIALLY FOR:

- > very high sample throughput
- > rather rough environment / handling
- > frequent spindle change
- > frequent change of location of the device

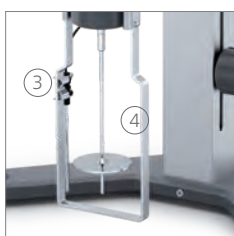

Your laboratory, our package

What kind of laboratory do you have? With us, you are sure to find the right package for viscosity measurement.

What do you need? Come and talk to us!

ROTAVISC Complete

The scope of delivery includes:

- ① ROTASTAND stand
- ② standard spindle set
- ③ temperature sensor
- ④ guard rail

[ROTAVISC lo-vi Complete](#) | Ident No.: 0025000310

[ROTAVISC me-vi Complete](#) | Ident No.: 0025000311

[ROTAVISC hi-vi I Complete](#) | Ident No.: 0025000312

[ROTAVISC hi-vi II Complete](#) | Ident No.: 0025000313

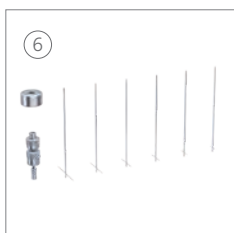

ROTAVISC HELI Complete

The scope of delivery includes:

- ⑤ HELISTAND stand
- ② standard spindle set
- ③ temperature sensor
- ④ guard rail
- ⑥ T-spindle set

[ROTAVISC lo-vi HELI Complete](#) | Ident No.: 0025008225

[ROTAVISC me-vi HELI Complete](#) | Ident No.: 0025008226

[ROTAVISC hi-vi I HELI Complete](#) | Ident No.: 0025008227

[ROTAVISC hi-vi II HELI Complete](#) | Ident No.: 0025008228

ROTAVISC SBS Complete

The scope of delivery includes:

- ① ROTASTAND stand
- ② standard spindle set
- ③ temperature sensor
- ④ guard rail

[ROTAVISC SBS me-vi Complete](#) | Ident No.: 0010007714

[ROTAVISC SBS hi-vi I Complete](#) | Ident No.: 0010007686

[ROTAVISC SBS hi-vi II Complete](#) | Ident No.: 0010007701

[ROTAVISC SBS me-vi HELI Complete](#) | Ident No.: 0010007716

[ROTAVISC SBS hi-vi I HELI Complete](#) | Ident No.: 0010007688

[ROTAVISC SBS hi-vi II HELI Complete](#) | Ident No.: 0010007703

Technical data

TECHNICAL DATA

Viscosity accuracy	1 %
Viscosity repeatability	0,2 %
Display	TFT
Motor rating output	4,8 W
Working temperature	min.: -100 °C max.: +300 °C
Speed	0,01 – 200 rpm
Setting accuracy speed	0,01 rpm
Temperature measurement resolution	0,1 K
Connection for ext. temperature sensor	PT 100
Graph function	Yes
Calibration option (temperature)	Yes
Overload protection	Yes
Operating mode	Timer and continuous operation
Attachment on stand	Extension arm
Interfaces	USB, RS 232, Analog output

GENERAL DATA

Weight	7,1 kg
Dimensions (W x H x D)	351 x 629 x 372 mm
Permissible ambient temperature	5 – 40 °C
Permissible relative humidity	50 %
Voltage	100 – 240 V
Frequency	50 / 60 Hz
Power input	24 W, Standby: 0,06 W
Protection class according to DIN EN 60529	IP 40

FOUR DEVICES. FOUR MEASURING RANGES.

ROTAVISC lo-vi

Viscosity measuring range	1 – 6 000 000 mPas
---------------------------	--------------------

ROTAVISC me-vi

Viscosity measuring range	100 – 40 000 000 mPas
---------------------------	-----------------------

ROTAVISC hi-vi I

Viscosity measuring range	200 – 80 000 000 mPas
---------------------------	-----------------------

ROTAVISC hi-vi II

Viscosity measuring range	800 – 320 000 000 mPas
---------------------------	------------------------

STAND FOR ROTAVISC

ROTASTAND

Stroke max.	200 mm
Diameter	16 mm
Dynamic load	5 kg
Dimensions (W x H x D)	351 x 318 x 246 mm
Weight	4,8 kg

HELISTAND

Stroke max.	142 mm
Diameter	16 mm
Dynamic load	3,2 kg
Overload protection	yes
Height adjustable safety switch	yes
Dimensions (W x H x D)	351 x 343 x 252 mm
Weight	5,5 kg
Permissible ambient temperature	0 - 40 °C
Permissible relative humidity	80 %
Protection class according to DIN EN 60529	IP 40
Voltage	220 - 230 / 100 - 115 V
Frequency	50/60 Hz
Power input max.	7 W

HRC 2 refrigerated and heating circulator



HRC 2 basic
Ident No.: 0025003742
HRC 2 control
Ident No.: 0025004524
H.SI.8 Tube
Ident No.: 004569000

Precise tempering to prepare your samples: The compact refrigerated and heating circulator HRC 2 control is renowned for its high energy efficiency, a working temperature range from -30 °C to 100 °C and a powerful and infinitely variable pressure and suction pump. The on-demand and speed-controlled compressor reduces noise and operating costs.

The HRC 2 control in combination with an external temperature sensor is perfectly suitable to precisely temper external closed or open applications.

The high-quality isolation of the 4 l bath allows fast heating and reduces heat input when cooling.

Using the external temperature control circuit is possible for up to 2,5 l thermofluid without a refill. The integrated hopper and drain valve ensure a safe and clean handling of the thermofluid. The easy-to-open front flap allows an easy cleaning of the cooling unit's air filter. There is a drain valve on the front side of the bath. A hose can be connected to empty the bath, so the user does not get in direct contact with the thermofluid.

STARVISC 200-2.5 control measuring stirrer



STARVISC 200-2.5 control
Ident No.: 0025003604

The only device that can do everything at the same time. During the mixing process a highly sensitive torque measuring sensor allows further conclusions on viscosity changes, directly in the product. This eliminates the regular sampling, rather time consuming offline measurement process. The viscosity can be correlated from the torque readings based on a well defined set-up under reproducible conditions. The modern TFT display is removable. This means that STARVISC can also be controlled from a safe distance. Even highly viscous substances can be intensively stirred using the powerful STARVISC stirrer. Quantities of up to 100 liters can be processed.



Laboratory Reactors

IKA lab reactors are the most unique systems when it comes to optimizing and reproducing chemical reaction, mixing, dispersing, and homogenization processes on a lab scale. The lab reactors can be individually customized to perform numerous tasks, including: production of creams and lotions, the grinding and disintegrating of solids and fibers in liquids or polymers, etc.



IKA Overhead Stirrers

Stirrers with perfect basic functions; compact and easy to use: The space-saving high performers of the IKA MICROSTAR and IKA MINISTAR series.

More robust variants can be found in the EUROSTAR series. For example, the new EUROSTAR 100 control P4 offers particularly strong and flexible stirring thanks to its reduction gear. Additionally, it is a great choice for use in laboratory reactors.



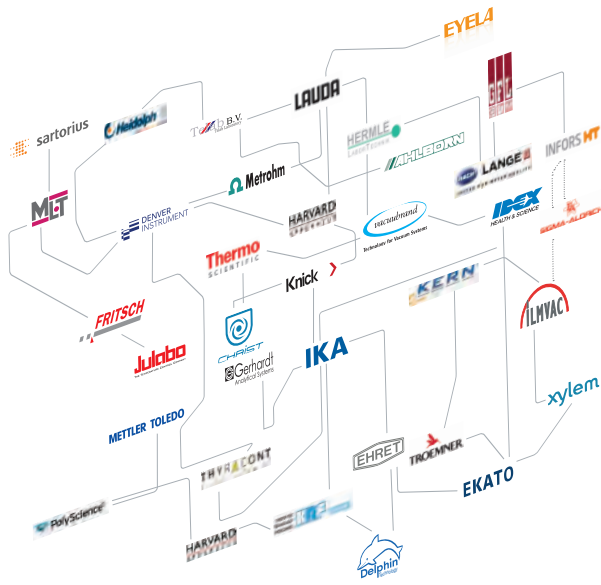

labworldsoft® 6

The universal laboratory software labworldsoft® 6 controls your lab devices, automates processes and documents measurements and results. labworldsoft® 6 can simultaneously network any number of laboratory devices using a PC. This makes the automation of your laboratory experiments and procedures easier and more efficient. Communication between the PC and the laboratory equipment is possible via various interfaces, such as RS 232, USB, Bluetooth or via network interfaces.

labworldsoft® 6 allows rapid recording of numerous physical parameters, such as torque, temperature, speed and pH-value. This can be displayed in various ways for ease of analysis and documenting e.g. on a y/t-diagram.

labworldsoft® 6 Visc

The downsized version labworldsoft 6 Visc software enables the automation of laboratory processes by connecting the ROTAVISC viscometers and STARVISC 200-2.5 control measuring stirrer to other devices, such as a thermostats, through a PC. The software is available as accessory and is compliant with FDA 21 CFR Part 11.

Ident No.: 0020101872



Accessories



SP RACK spindle rack

The stainless steel rack (AISI 304 / 1.4301) for ROTAVISC spindles offers sufficient space for a variety of different spindles for hanging storage close to the device or for drying.

Ident No.: 0020104809



VOL-C-RTD-2.1 chamber

The optional chamber VOL-C-RTD-2.1 for VOLS-1 is especially suitable for expensive and valuable samples. A temperature sensor is already integrated in the chamber and thus allows for temperature measurement during viscosity determination.

Ident No.: 0025007064



DWB 600 double-walled beaker

The double-walled beaker DWB 600 has a filling volume of 600 ml. It can be connected to an external cooling or heating source and is therefore suitable for tempering the sample inside the beaker.

Ident No.: 0020024575



BH 600 clamp

The BH 600 clamp is suitable for 600 ml beakers. It fixes them, for example, to an IB R 9 or IB R 20 plastic bath.

Ident No.: 0025000400



Hook Connector for spindles

The Hook Connector enables the spindles to be easily hooked to the ROTAVISC measuring system.

Ident No.: 0025000338



Quick Connector for spindles

The Quick Connector enables the spindles to be connected directly to the ROTAVISC measuring System.

Ident No.: 0025000339



PT 100.8 temperature sensor

Temp. sensor, stn. steel, Ø3 mm, 75 mm for ROTAVISC viscometers

Ident No.: 0025000413

Accessories



DINS-1 DIN adapter

Adapter to measure the viscosity according to DIN 53019. The set includes a double jacket to quickly heat up or cool down the sample as well as a coaxial cylinder system for the analysis of the sample at a specific shear rate.

Ident No.: 0025000387



VOLS-1 adapter

Adapter to measure the viscosity of especially valuable and expensive samples. A double jacket with temperature sensor to quickly heat up or cool down the sample as well as a coaxial cylinder system for the analysis of the sample at a specific shear rate is included. Further spindles and chambers for different volumes can be purchased separately.

Ident No.: 0025000352



ELVAS-1 adapter

Adapter to measure very low viscosities, which are not measured by the standard spindle. A double jacket to quickly heat up or cool down the sample as well as a coaxial cylinder system for the analysis of the sample at a specific shear rate is included.

Ident No.: 0025000390

ELVAS-C-C stainless steel chamber

Closed stainless steel chamber for the adapter spindle set ELVAS-1.

Ident No.: 0025008373



O DIN S-1 open DIN spindle set

The set includes a single-wall-open-jacket to quickly dive into the sample liquid as well as a coaxial cylinder system for the analysis of the sample at a specific shear rate and shear stress is included. The maximum measurable viscosity is 50 000 mPas.

Ident No.: 0025000326



VAN-1 vane spindle set

The vane spindle set allows the viscosity measurement of suspensions. Four vane spindles are included in the delivery.

Ident No.: 0025000407



SAS-1 spiral adapter

Spiral adapter to measure the viscosity of very sticky and other viscous samples. Additionally, it is possible to analyse the fluid behavior of different shear rates.

Ident No.: 0025000377

Accessories



SP-5

SP-6

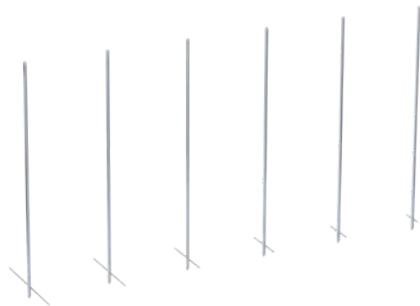

T-SP-6 – T-SP-1

SPINDLES SINGLE

Product	Description	Ident. No.
SP-1	Standard spindle	0025006828
SP-2	Standard spindle	0025006829
SP-3	Standard spindle	0025006830
SP-4	Standard spindle	0025006831
SP-5	Standard spindle	0025006832
SP-6	Standard spindle	0025006833
SP-7	Standard spindle	0025006834
SP-8	Standard spindle	0025006835
SP-9	Standard spindle	0025006836
SP-10	Standard spindle	0025006837
SP-11	Standard spindle	0025006838
SP-12	Standard spindle	0025006839
T-SP-1	T-spindle	0025008238
T-SP-2	T-spindle	0025008239
T-SP-3	T-spindle	0025008240
T-SP-4	T-spindle	0025008241
T-SP-5	T-spindle	0025008242
T-SP-6	T-spindle	0025008243
T-SP-nut	T-spindle nut	0020108874
T-SP-coupling	T-spindle coupling	0020108842
VAN-SP-1	Vane spindle	0025006853
VAN-SP-2	Vane spindle	0025006854
VAN-SP-3	Vane spindle	0025006855
VAN-SP-4	Vane spindle	0025006856
VAN-SP-5	Vane spindle	0025008376
S-SP	Spiral spindle	0025006843
S-C-1	Chamber for S-SP spiral spindle	0020108896
SCB	Spindle brush for S-SP	0020108882

Accessories



VOL-SP-7.1



VOL-SP-2.1



VOL-SP-9



VOL-SP-11



VOL-C-RTD-3.8



VOL-C-RTD-4.2

Product	Description	Ident. No.
VOL-SP-6.7	Spindle for VOLS-1, 6,7 ml	0025006845
VOL-SP-7.1	Spindle for VOLS-1, 7,1 ml	0025006849
VOL-SP-16.1	Spindle for VOLS-1, 16,1 ml	0025006848
VOL-SP-10.4	Spindle for VOLS-1, 10,4 ml	0025006850
VOL-SP-11	Spindle for VOLS-1, 11 ml	0025006851
VOL-SP-13.5	Spindle for VOLS-1, 13,5 ml	0025006852
VOL-SP-9	Spindle for VOLS-1, 9 ml	0025006846
VOL-SP-9.4	Spindle for VOLS-1, 9,4 ml	0025006847
VOL-SP-2.1	Spindle for 2,1 ml chamber	0025007061
VOL-C-RTD-1	VOL-C-RTD-1 chamber	0025007603
VOL-C-RTD-2.1	2,1 ml chamber for VOLS-1	0025007064
VOL-SP-3.8	Spindle for 3,8 ml chamber	0025007062
VOL-C-RTD-3.8	3,8 ml chamber for VOLS-1	0025007065
VOL-SP-4.2	Spindle for 4,2 ml chamber	0025007063
VOL-C-RTD-4.2	4,2 ml chamber for VOLS-1	0025007066
VOLS 1.11	Extension connector	0020107301
VOLS 1.21	Cover for VOLS chamber	0020108881
ELVAS-SP	ELVAS Spindle	0025006844
ELVAS-C	ELVAS sample chamber (open)	0020107138
ELVAS-C-C	Closed chamber for ELVAS-1	0025008373
DIN-SP-5	DIN spindle 5	0025006840
DIN-SP-6	DIN spindle 6	0025006841
DIN-SP-7	DIN spindle 7	0025006842
DIN-C-1	Chamber for DIN-SP-5	0020108883
DIN-C-2	Chamber for DIN-SP-6, DIN-SP-7	0020108885
O-DIN-C-1	Open chamber for DIN-SP-5	0020108887
O-DIN-C-2	Open chamber for DIN-SP-6	0020108888
O-DIN-C-3	Open chamber for DIN-SP-7	0020108889
CC-1	Chamber cap (6 pcs.) for ELVAS / DINS	0020107043

Accessories



Standard silicone oil

With the certified standard silicone oil you are able to check the measurement accuracy of your ROTAVISC. The certificate is part of the delivery. Standard silicone oil with different viscosities or temperature conditions can be ordered customer-specifically.

.....

CAL-O-5 standard silicone oil
5 mPas
Ident No.: 0025000397

.....

CAL-O-10 standard silicone oil
10 mPas
Ident No.: 0025000398

.....

CAL-O-50 standard silicone oil
50 mPas
Ident No.: 0025000399

.....

CAL-O-100 standard silicone oil
100 mPas
Ident No.: 0025000434

.....

CAL-O-500 standard silicone oil
500 mPas
Ident No.: 0025000435

.....

CAL-O-1000 standard silicone oil
1000 mPas
Ident No.: 0025000436

.....

CAL-O-5000 standard silicone oil
5000 mPas
Ident No.: 0025000437

.....

CAL-O-12500 standard silicone oil
12 500 mPas
Ident No.: 0025000466

.....

CAL-O-30000 standard silicone oil
30 000 mPas
Ident No.: 0025000467

.....

CAL-O-60000 standard silicone oil
60 000 mPas
Ident No.: 0025000468

.....

CAL-O-100000 standard silicone oil
100 000 mPas
Ident No.: 0025000469

Accessories



T-SP-Set T-spindle set

The T-spindle set is particularly suitable for the measurement of non-flowing samples, such as creams, pastes or gelatin.

Ident No.: 0025007765



SP set-1 standard spindle set

The standard spindle set SP set-1 includes four spindles (SP1, SP2, SP3, SP4). It is particularly suitable for viscosity determination in combination with the rotary viscometers ROTAVISC lo-vi Complete.

Ident No.: 0025000319



SP set-2 standard spindle set

The standard spindle set SP set-2 includes six spindles (SP7, SP8, SP9, SP10, SP 11, SP12). It is particularly suitable for viscosity determination in combination with the rotary viscometers ROTAVISC me-vi, hi-vi I or hi-vi II Complete.

Ident No.: 0025000329



ROTASTAND stand for ROTAVISC

Ident No.: 0020006787



HELISTAND electrical stand for ROTAVISC

Ident No.: 0025007567

YOU ARE ALREADY WORKING WITH ROTAVISC?

Extend its application range with the HELISTAND Set including an electric stand and six T-spindles.

HELISTAND SET

Ident. No. 0025008224

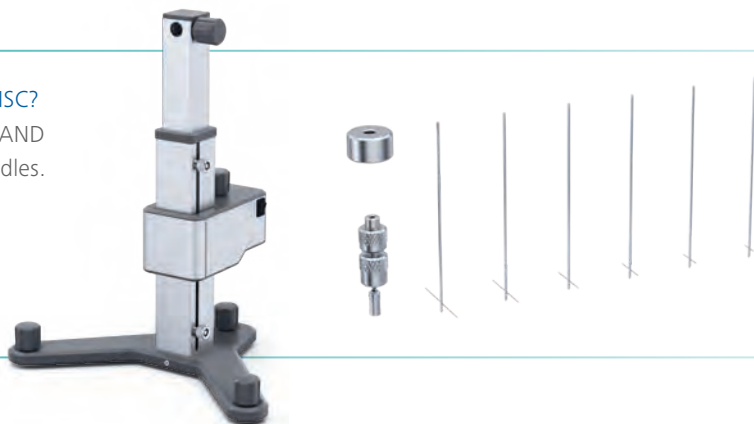

Good to know

Infinitely variable measurement according to the SEARLE principle

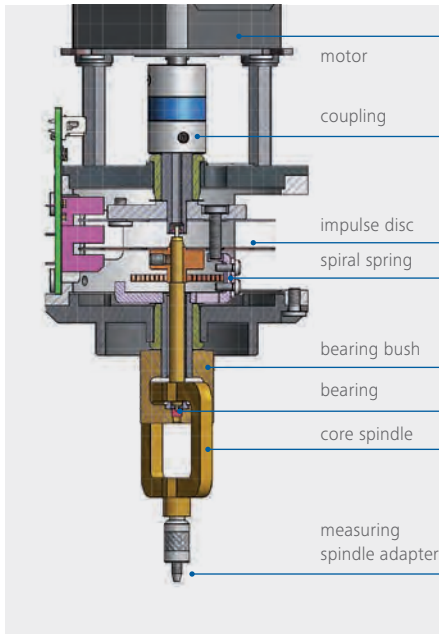

The ROTAVISC measurement of viscosity is based on the SEARLE principle. A measuring spindle rotates in the substance being examined. The viscosity of the sample is determined from the torque required to achieve a given speed, taking into account the spindle used. All this happens automatically without users having to make manual adjustments to the settings.

The viscosity of a substance is often not a constant factor; it depends on the temperature, pressure and other influences. Therefore, different viscosity values will be recorded for the same substance at different shear rates and temperatures, for instance.

Usability

Using the appropriate accessories, any fluid sample, even down to the low-viscosity range, can be measured properly and reproducibly. This also applies to making relative comparisons. It is also possible to adapt the device to user-specific measuring containers, so that decanting the sample - and thus possibly changing the sample structure - is not required.

Due to the extensive range of measuring geometries, ROTAVISC is suitable for all common measuring requirements and all conceivable free-flowing media. Measurement results can be provided in both relative and absolute terms. The extensive range of accessories and an intuitive user interface ensure that ROTAVISC is fully usable. The necessary parameters can be set in no time, meaning that the staff responsible for the rheological measurements hardly require any training.



Good to know

Technical features

Measurements according to DIN 53019, ISO 2555 and relative measurements are possible with the ROTAVISC and the corresponding measuring spindles. ROTAVISC detects the sample temperature, which is important for the viscosity measurement, from a PT 100 sensor that can be immersed in the substance. You can store measurement methods and automate processes without even connecting to a computer. This makes it possible to define both step and ramp programs, which can then be standardized over and over again. The results displayed on the device as a graph.

Temperature control

The viscosity of a sample is always dependent on its temperature. Therefore, the sample should always be measured isothermally. The IKA tempering equipment meets this requirement by using immersion circulators as well as cryostats for temperatures ranging from -30 °C to 250 °C.

This widens ROTAVISC's field of application, since the IKA laboratory software (see above) for controlling the thermostats can be used to specify rheological temperature ramps and record the change in viscosity.

Verification / Calibration

The ISO 17025 standard requires that measuring instruments be verified. ROTAVISC offers users the option of carrying out this verification themselves. Thanks to the extensive range of appropriate standard fluids, users are fully autonomous, i.e. able to check their device without external maintenance costs. This allows them to check whether all specified readings are within the specified measurement accuracy range.

Viscometer standards

ROTAVISC measures according to international standards, e.g. according to ISO 1652, ISO 2555 and GB 10247.





Personal care
Environment
Sewage

Industries

Viscosities play a role in the most diverse of industries. Our product portfolio is ideally oriented for viscosity measurement in the following fields of application:



Food industry
Research
Teaching
Materials sciences



Electronics industry
Beverages
Cosmetics



Nanotechnology
Commodities
Textiles



Pharmaceutical industry
Medicines
Biotechnology



Paper
Oil industry
Chemical industry

FAQ

1. Which IKA rotational viscometer is the most suitable for my sample?

lo-vi: for juices, solvents, edible oils, inks, liquid soap.

me-vi: for paints / varnishes, mayonnaise, dairy products, ketchup.

hi-vi I & *hi-vi II*: for pastes, ointments, molasses, gels.

2. How can the accuracy of the ROTAVISC be checked?

IKA sells standard liquids with a viscosity determined at 25 °C. The user can check the device using these fluids.

3. How is the spindle mounted on the device?

The delivery includes three different adaptations.

1. The spindle is screwed onto the device.
2. The spindle is attached to the device by means of a quick-fitting adapter.
3. The spindle is attached to the device by means of a hook adapter.

4. How long does a measurement take?

To obtain a stable viscosity value, the spindle should have completed 3 to 4 full revolutions in the medium. The lower the speed, the longer a measurement takes.

5. How deep does the spindle have to be immersed into the test medium?

Each spindle has a mark on the shaft. The spindle must be immersed into the medium up to this point.

6. What is the smallest viscosity that can be measured using ROTAVISC?

1 mPas with *lo-vi* and ELVAS-1 at 60 rpm.

7. How exactly does the IKA ROTAVISC work?

The rotational viscometer measures the torque required to turn the spindle immersed in a medium. The spindle is driven by a motor that uses a calibrated spring. The deflection serves as a measurement of the torque and is shown in the display as M%.

8. How much sample volume is needed?

The standard spindles in the scope of delivery are suitable for a volume of approx. 500 ml in the 600 ml beaker (low form). Smaller sample volumes can be measured with the absolute measuring systems (coaxial measuring system), such as with the VOLS-1 adapter.

9. Why does ROTAVISC measure different viscosities for the same sample?

Generally, viscosity is not a substance-specific constant. The viscosity describes a substance in a well-defined state, for instance at temperature X and speed Y. There are samples which reduce their viscosity with increasing speed, for example ketchup (shear thinning / pseudoplastic). For other samples, the viscosity increases with increasing speed, for example starch solutions (shear thickening / dilatant). Also there are samples that do not change their viscosity either as the speed increases or decreases, such as silicone oil (Newtonian fluid).

10. Which measured values does ROTAVISC output?

Temperature:	°C or °F
Speed:	rpm
Measuring time:	hh:mm:ss
Torque:	M%
Viscosity:	mPas, cP, m ² /s, cSt
Stop conditions:	Time, torque, temperature, viscosity
Density:	g/cm ³
Shear rate:	1/s (when using a coaxial measuring system)
Shear stress:	Pa (when using a coaxial measuring system)

11. How high should the maximum speed be?

Here it is important that the speed and the spindle are chosen so that the laminar flow range is not deviated from. Otherwise, the viscosity values will be too high. For the geometries SP-1, SP-2, SP-6 and ELVAS-SP, the following transition points to a turbulent flow were determined.

1. SP-1 *lo-vi*, 15 mPas at 60 rpm > rpm / mPas = 4
2. SP-2 *lo-vi* 100 mPas at 200 rpm > rpm / mPas = 2
3. SP-6 *me-vi* 100 mPas at 50 rpm > rpm / mPas = 0,5
4. ELVAS-SP 0,85 mPas at 60 rpm > rpm / mPas = 70,6

If the ratio of rpm / mPas exceeds these values, turbulent conditions can occur with the spindles listed. Artificially higher viscosity values can occur with the geometries VAN-SP-1 to VAN-SP-4, due to turbulence at speeds of more than 10 rpm.