

Montageanleitung Assembly instructions



Beachten Sie die Betriebsanleitung des Gerätes!
Observe the operating instructions of the device!

Auspacken / Unpacking

R 401 Stirring shaft protector

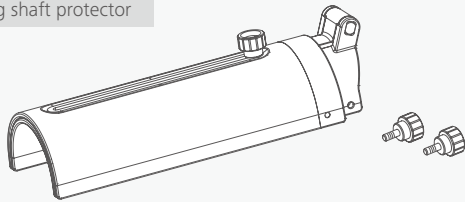

R 402 Stirring shaft protector

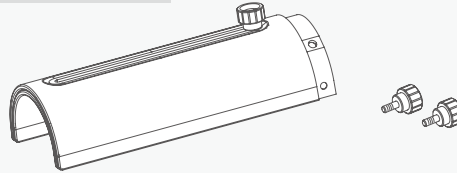

R 402.1 Adapter

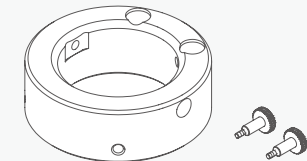

Aufstellen / Installation



Sicherheits- und Warnhinweise:

Thema (DE)	Kurzbeschreibung / Hinweis (DE)
Montagezustand	Nur bei vollständig stillstehender Rührwelle montieren (Gefahr durch rotierende Teile).
Elektrische Sicherheit	Gerät vor Montage immer vom Strom trennen; nicht in feuchter Umgebung arbeiten.
Qualifiziertes Personal	Arbeiten dürfen nur durch geschulte und erfahrene Personen erfolgen.
Kompatibilität	Nur Originalteile und freigegebene Geräte verwenden; keine Eigenmodifikationen.
Mechanischer Sitz	Schutz muss vollständig einrasten und fest sitzen; keine Berührung mit der Rührwelle zulassen.
Bauteilzustand	Keine beschädigten oder verformten Teile verwenden (Bruch /Versagensgefahr).



Safety and Warning Instructions:

Topic (EN)	Short Description / Instruction (EN)
Assembly condition	Only install when the stirring shaft is completely stopped (risk of rotating parts).
Electrical safety	Always disconnect device from power before installation; do not work in humid environments.
Qualified personnel	Work may only be carried out by trained and experienced personnel.
Compatibility	Use only original parts and approved devices; no self modifications.
Mechanical fit	The stirring shaft protector must fully lock into place and sit firmly; no contact with the stirring shaft.
Component condition	Do not use damaged or deformed parts (risk of breakage/failure).



	R 401	R 402	R 402.1	Graph
EUROSTAR 20/40/60/100 digital	√			Fig. A
EUROSTAR 60/100 control	√			

	R 401	R 402	R 402.1	Graph
NANOSTAR 7.5 digital		√	√	Fig. B
MICROSTAR 7.5/15/30 digital		√	√	
MICROSTAR 7.5/15/30 control		√	√	
MINISTAR 20/40/80 digital		√	√	
MINISTAR 20/40/80 control		√	√	

	R 401	R 402	R 402.1	Graph
EUROSTAR 100 P4 control		√		Fig. C
EUROSTAR 200 digital		√		
EUROSTAR 200 control		√		
EUROSTAR 400 digital		√		
EUROSTAR 400 control		√		
EUROSTAR 660 high torque control		√		
STARVISC 200-2.5 control		√		
RW 20/28 digital		√		

/// Fig. A:

Befestigen des Rührwellenschutz R 401
Securing the stirring shaft protector R 401

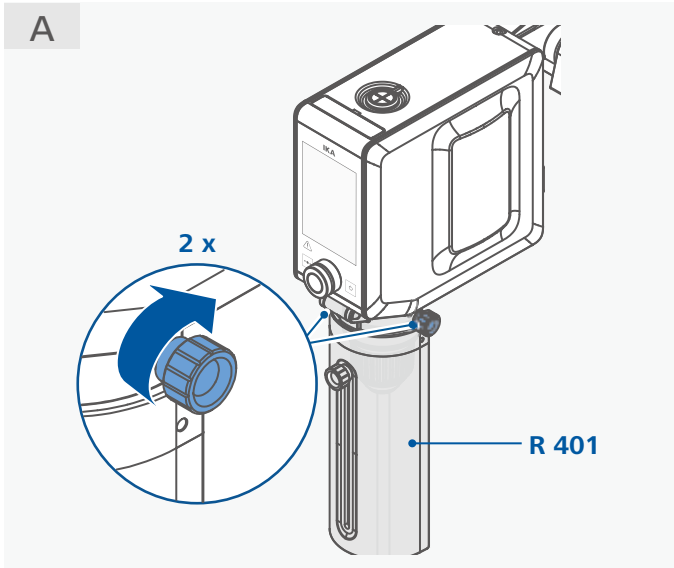

/// Fig. B:

Befestigen des Adapters R 402.1 und des Rührwellenschutz R 402
Securing the adapter R 402.1 and stirring shaft protector R 402

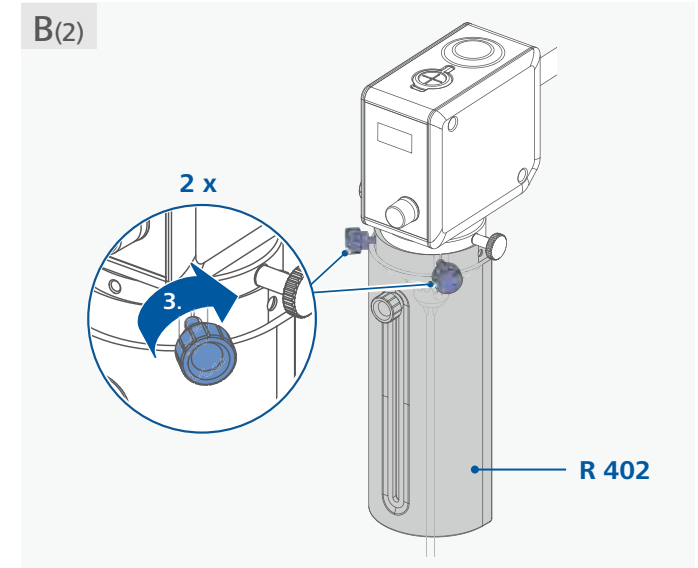
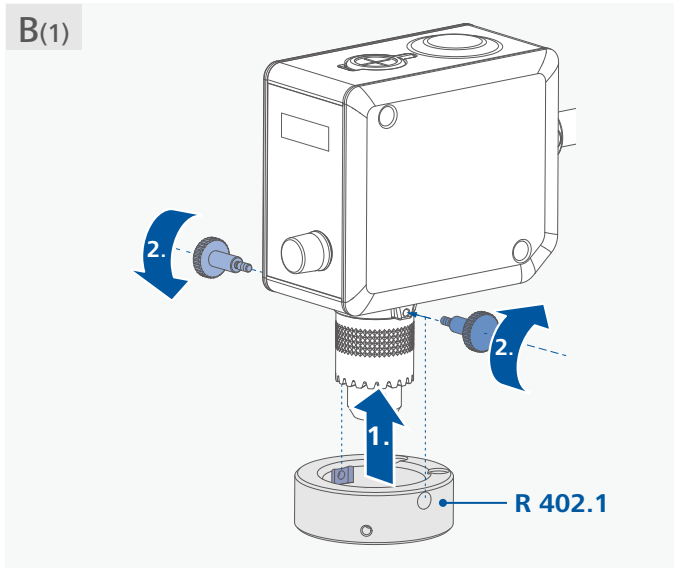

/// Fig. C:

Befestigen des Rührwellenschutz R 402
Securing the stirring shaft protector R 402

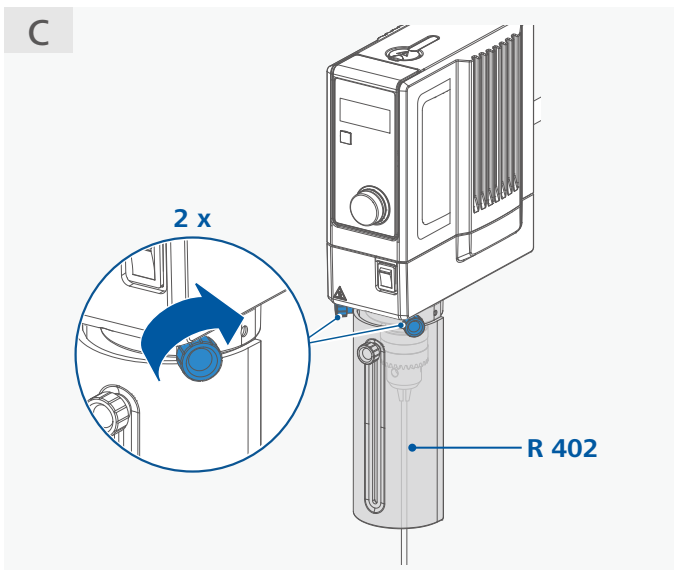

/// Fig. A/B/C:

Einstellen des Rührwellenschutzes R 401/R 402
Adjusting the stirring shaft protector R 401/R 402

