

IKA

designed for scientists

IKA T10 battery

imLab
SCIENTIFIC EQUIPMENT
FOR LABORATORY & INDUSTRY

@ Web contact

www.imlab.eu
info@imlab.eu

☎ Phone

 +33(0)3 20 55 19 11
 +32(0)16 73 55 72

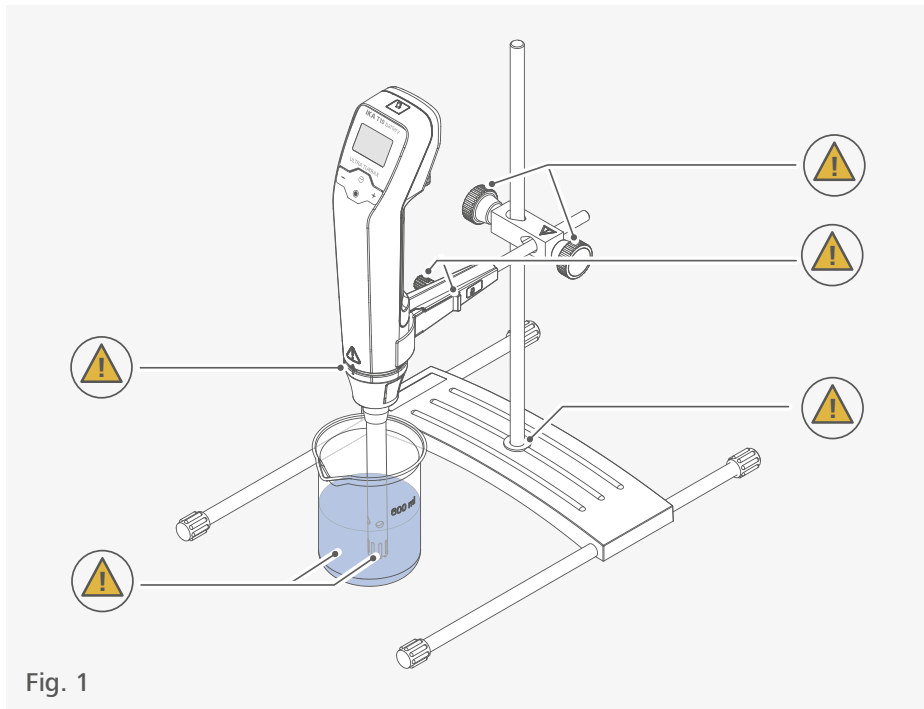











Fig. 1

	EU Declaration of conformity	6
	Explication of warning symbols	6
	Safety instructions.....	7
	Intended use.....	11
	Useful information	12
	Drive.....	12
	Unpacking	13
	Installation.....	14
	Operator panel and display	22
	Operation	24
	Menu navigation and structure	27
	Interfaces and outputs	29
	Maintenance and cleaning.....	31
	Warning message	33
	Error codes	33
	Accessories	35
	Permitted dispersing tools	35
	Technical Data	36
	Warranty	37



EU Declaration of conformity

We declare under our sole responsibility that this product corresponds to the directives: 2014/35/EU, 2006/42/EC, 2014/30/EU and 2011/65/EU and conforms with the following standards or normative documents: EN 61010-1, EN 6010-2-051, EN 61326-1, EN 60529 and EN ISO 12100.

A copy of the complete EU Declaration of Conformity or further declarations of conformity can be requested.







Explication of warning symbols

/// Warning symbols

-  **Danger!** Indicates an (extremely) hazardous situation, which, if not avoided, will result in death, serious injury.
-  **Warning!** Indicates a hazardous situation, which, if not avoided, can result in death, serious injury.
-  **Caution!** Indicates a potentially hazardous situation, which, if not avoided, can result in injury.
-  **Notice!** Indicates practices which, if not avoided, can result in equipment damage.
-  **Caution!** Indicates crushing risk to fingers/hand.
-  **Caution!** Indicates a hazardous situation that can cause from a hot surface.

/// General Symbols

- A** — Position number
-  **Correct/Result!**
Shows the correct execution or the result of an action step.
-  **Wrong!**
Shows the incorrect execution of an action step.
-  **Note!**
Displays action steps that require particular attention to detail.
-  **Closed lock**
Indicates the status of "locked".
-  **Open lock**
Indicates the status of "Unlocked".

Safety instructions



/// General information

- › **Read the operating instructions completely before starting up and follow the safety instructions.**
- › Keep the operating instructions in a place where it can be accessed by everyone.
- › Ensure that only trained staff work with the device.
- › Follow the safety instructions, guidelines, occupational health and safety and accident prevention regulations.

Warning!

- › Beware of the risk of:
 - flammable materials
 - glass breakage
 - sharp edges on the dispersing tool.

Caution!

- › Wear your personal protective equipment in accordance with the hazard category of the media to be processed. There is a risk from:
 - splashing and evaporation of liquids
 - body parts, hair, clothing and jewellery getting caught.

Notice!

- › Pay attention to the marked sites in Fig. 1.
- › The device must only be used in a technically perfect condition.
- › Do not cover the ventilation slots on the drive in order to ensure adequate cooling of the drive.
- › Abrasion of the device or the rotating accessories can get into the medium you are working on.

/// Device setup

Notice!

- › Set up the device in a spacious area on an even, stable, clean, non-slip, dry and fireproof surface.
- › Consider on a good stability of entire structure. The centre of gravity of the assembly must lie within the entire structure.
- › Ensure that the dispersing tool is securely properly into the drive unit.
- › All screw connections must be properly tightened.
- › Check that the turning knobs are secure and tighten if necessary.
- › When working with glass vessels, the dispersing tool must not come into contact with the glass.
- › Before switching on the dispersing device make sure that the dispersing tool shaft is immersed in the medium. Observe the operating instructions of the dispersing tools.
- › The distance between the dispersing tool and the vessel bottom should not be less than 10 mm.
- › Use the dispersing tool always inside the dispersing vessel.
- › Do not use the device without a dispersing tool.

/// Charging the built-in battery pack

Caution!

- › The built-in battery pack in the device must only be charged with the original power supply unit and the original USB (C-C) cable. Incompatible charger may damage the battery pack and the device or even create a risk of fire.
- › An incompatible USB (C-C) cable is recognized by the device and prevents charging or mains operation.

Notice!

- › The built-in battery pack in the device supplied is partially charged. To ensure full capacity of the battery pack, fully charge the battery pack before using the device for the first time.
- › The built-in battery pack can only be charged when the device is switched on with the slide switch (A) but the device is not running.
- › The capacity of the built-in battery decreases over time. Failure may occur if the device is not used for a long period of time. Fully recharge the device before using it again.
- › To ensure a long life of the built-in battery, if the device is not used for a long time, we recommend charging it to about 50% every 6 months.
- › Disconnect the device from power sources (switch the slide switch (A) at position 0) when not in use for long time.

/// Working with the device

Danger!

- › Do not use the device in explosive atmospheres, it is not EX-protected.
- › With substances capable of forming an explosive mixture, appropriate safety measures must be applied, e.g. working under a fume hood.
- › To avoid body injury and property damage, observe the relevant safety and accident prevention measures when processing hazardous materials.
- › Only process media that will not react dangerously to the extra energy produced through processing. This also applies to any extra energy produced in other ways, e.g. through light irradiation.
- › Pathogenic materials must only be processed in closed vessels under a suitable fume hood. If you have any questions, please contact IKA application support.

Warning!

- › When you change or handle the dispersing tool, switch off the device using the slide switch (A) and disconnect the USB cable.

Caution!

- › Do not touch rotating parts during operation.

Caution!

- › The dispersing tool and the coupling flange can become hot during the operation.
- › If a dispersing tool is not inserted into the drive flange as far as the mark it can become extremely hot in operation and thus suffer damage.

Caution!

- › Be aware that the device starts with the set speed, which is shown on the display. If uncertain start with the lowest speed and increase it gradually.
- › Reduce the speed if the medium splashes out of the vessel because the speed is too high.
- › There may be electrostatic discharges between the medium and the dispersing device shaft which could pose a direct danger.

Notice!

- › Covers or parts that can be removed from the device without tools must later be refitted to ensure safe operation. This will prevent the infiltration of foreign objects, liquids and other contaminants.
- › Never run dispersing tools dry, as the gasket and bearings will be destroyed if the tools are not cooled by the medium.
- › In the event of unbalance or unusual noises, switch off the device immediately. Replace the dispersing tool. If there is no difference after the change of the dispersing tool, return it to the dealer or the manufacturer along with a description of the fault.
- › Ensure that the stand does not start to move.

- › The device is also suitable for hand-held operation.

/// Using and storage condition

Caution!

- › The device can only be stored and used indoors. The ingress of moisture into the device increases the risk of an internal short circuit.

Notice!

- › The device can be stored and used in locations with an ambient temperature of 5 °C to 40 °C. Using or storing the device outside of the recommended temperature ranges may shorten the built-in battery pack life or cause the device to stop working properly.
- › Do not place the device in hot areas such as close to heating devices. Doing so may damage the device, or cause the built-in battery pack to explode.
- › Do not use the device in areas prone to dripping or splashing water. In case the device gets wet, unplug all cables, power off the device before cleaning. Allow it to dry thoroughly before powering it on again. Do not attempt to dry the device with an external heat source, such as a microwave oven or hair dryer.
- › Do not store or use your device in areas with high concentrations of dust or airborne materials. Dust or foreign materials can cause your device to malfunction and may result in fire.
- › Avoid dramatic changes in temperature or humidity when using the device, as condensation may form on or within the device.

- › Turn off the device with slide switch (A) if you store the device for a long time and do not use it: This will significantly reduce the discharge of the battery pack.

/// Power supply / switching off the device

Caution!

- › **Safe disconnection the device from power:**
The device is only disconnected from the power supply when the USB cable has been disconnected and the slide switch (A) has been set to position 0.
- › Always safe disconnection the device from power before fitting accessories or cleaning.

- › The device does not start up again automatically following a cut in the power supply.

/// Accessories

- › Protect the device and accessories from bumps and impacts.
- › Check the device and accessories beforehand for damage each time you use them. Do not use damaged components.
- › Only dispersing tool approved by IKA may be used.
- › Safe operation is only guaranteed with the accessories described in the "Accessories" chapter.

/// Maintenance

- › A significantly reduced working period after charging indicates that the built-in battery pack should be replaced.
- › The built-in battery pack in the device can be replaced by IKA service or an IKA authorized service provider.

/// Disposal instructions

- › The device, accessories, packaging and batteries must be disposed of in accordance with local and national regulations.
- ›  Do not throw used battery packs into your household waste. Dispose of them properly in accordance with statutory regulations. End users are obliged by law to return all used disposable and rechargeable batteries. Throwing them into the household waste is prohibited. Disposable/rechargeable batteries containing harmful substances are marked with this symbol to indicate that they may not be disposed of as household waste.

Intended use

/// Use

When used in combination with one of IKA recommended dispersing elements, the drive unit is a high-speed dispersing and emulsifying unit capable of handling free-flowing and liquid media in batches.

Production of:

- › Emulsions
- › Dispersions
- › Wet crushing

Operating modes:

- › Hand-held
- › On stand

/// Range of use

Indoor environments similar to that a laboratory of research, teaching, trade or industry.

The safety of the user cannot be guaranteed:

- › If the device is operated with accessories that are not supplied or recommended by the manufacturer.
- › If the device is operated improperly or contrary to the manufacture's specifications.
- › If the device or the printed circuit board are modified by third parties.



Useful information

Dispersion is the dissolution and diffusion of a solid, liquid or gaseous phase in a liquid that is not consolute with that phase.

The rotor/stator principle:

Due to the high rotation speed of the rotor, the medium to be processed is automatically drawn axially into the dispersion head and then forced radially through the slots in the rotor/stator arrangement. The high accelerations acting on the material produce extremely strong shear and thrust forces. In addition, high turbulence occurs in the shear gap between rotor and stator, which provides optimum mixing of the suspension.

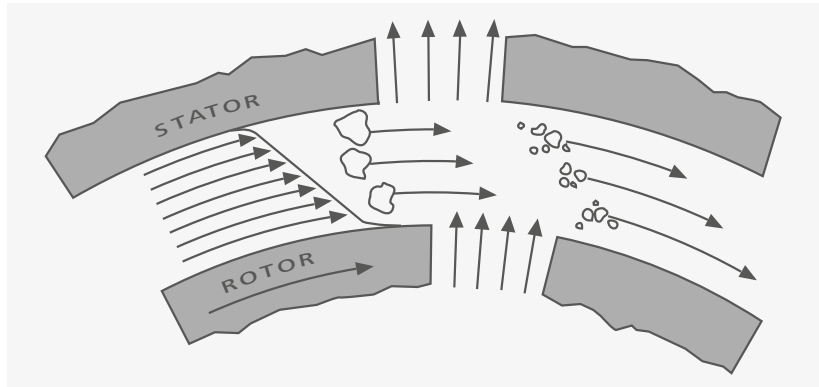

The dispersion effectiveness is heavily dependent on the product of the shear gradient and the time the particles spend in the shear zone. The optimum range for the circumferential velocity of the rotor/stator arrangement is 6–24 m/s.

A processing time of a few minutes is usually sufficient to produce the desired fineness. Long processing times bring only insignificant improvements in the obtainable fineness; the energy expended serves merely to increase the temperature of the medium.

Drive

The open up a wide range of possibilities for dispersion technology in the conventional laboratory with a respective performance output of approximately 25 watts at 30000 rpm. The speed is set by using the button (B) and button (E). The motor speed can be read from the LCD display. For example, a value of 13.6 corresponds to 13600 rpm.

Unpacking

- > Please unpack the device carefully.
- > Any damage should be notified immediately to the shipping agent (post office, railway network or logistics company).

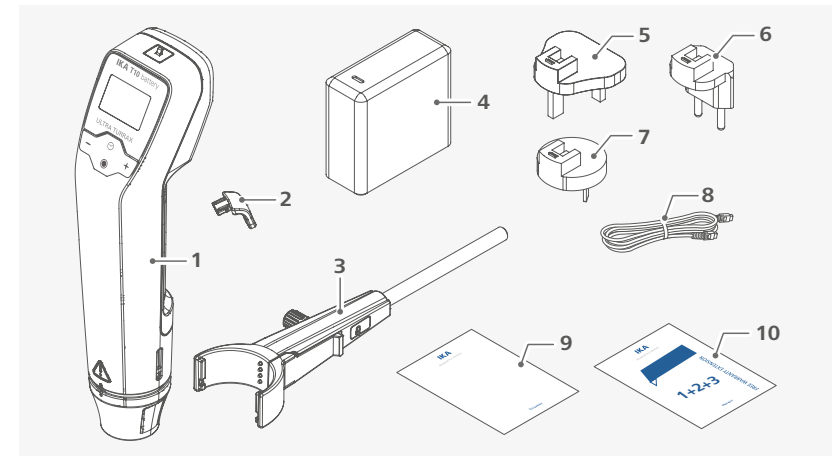

1	IKA T 10 battery	6	Exchangeable adapter (Europe)
2	Handle (small/large)	7	Exchangeable adapter (Australia)
3	R 200 C clamp	8	USB cable
4	Power supply	9	User guide
5	Exchangeable adapter (UK)	10	Warranty card



Installation

/// Handle for hand-held operation

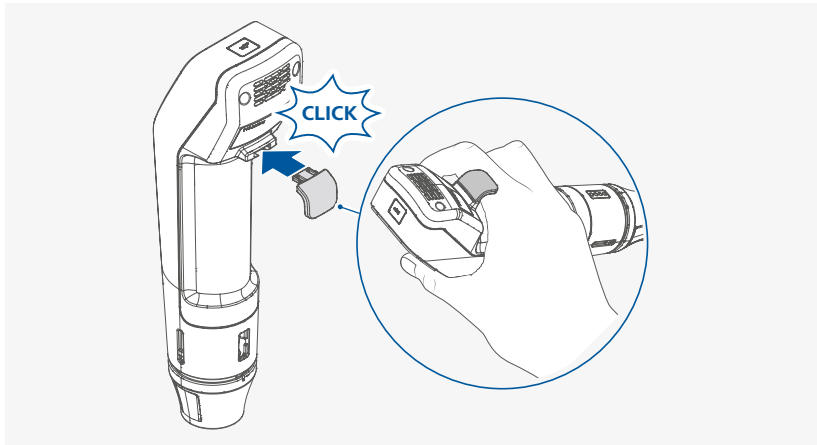

i Attach the handle suitable for your hand size.

/// Securing the cross sleeve to the stand

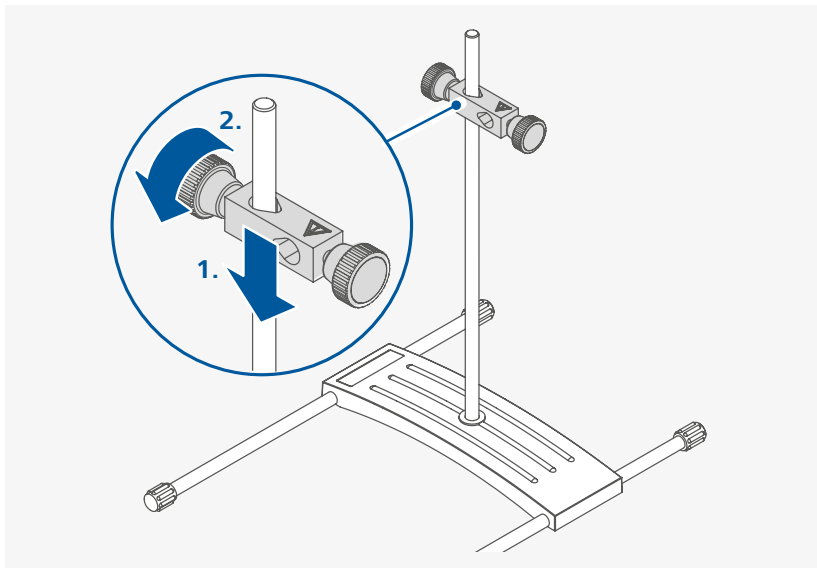

/// Securing the clamp to the cross sleeve

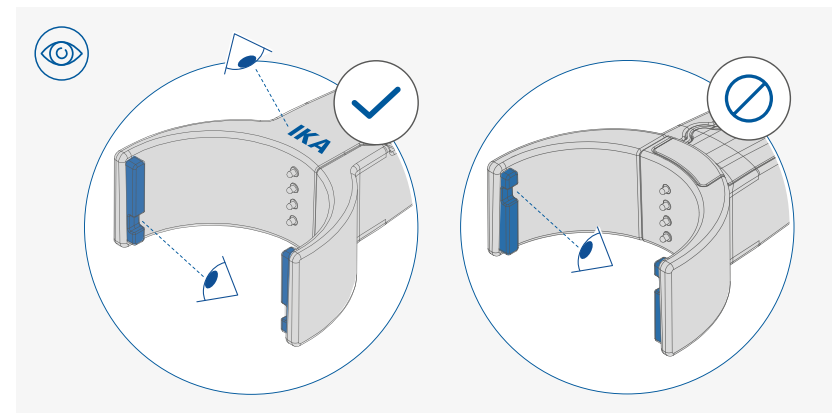
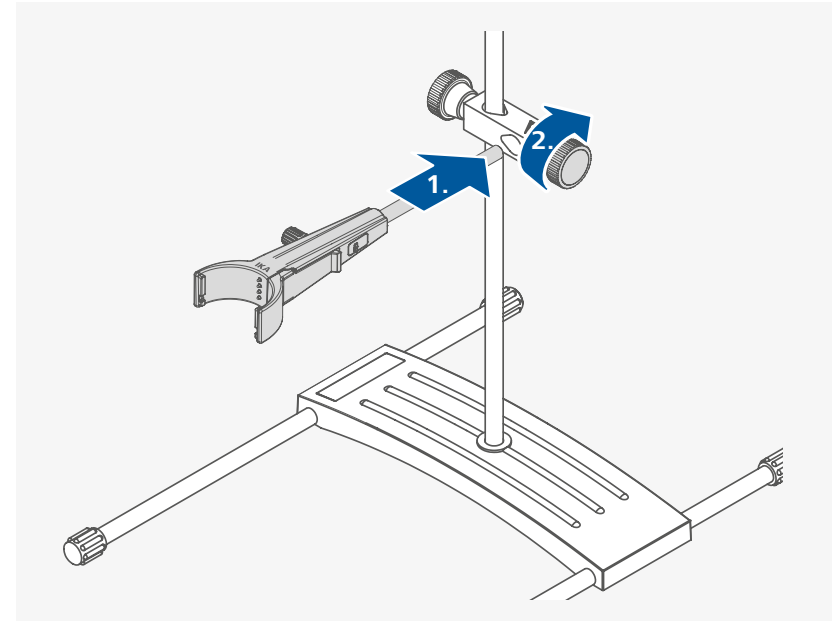

⚠ Notice!

› Ensure that the clamp is correctly secured. The inscription "IKA" must point upwards.

/// Securing the device to the clamp

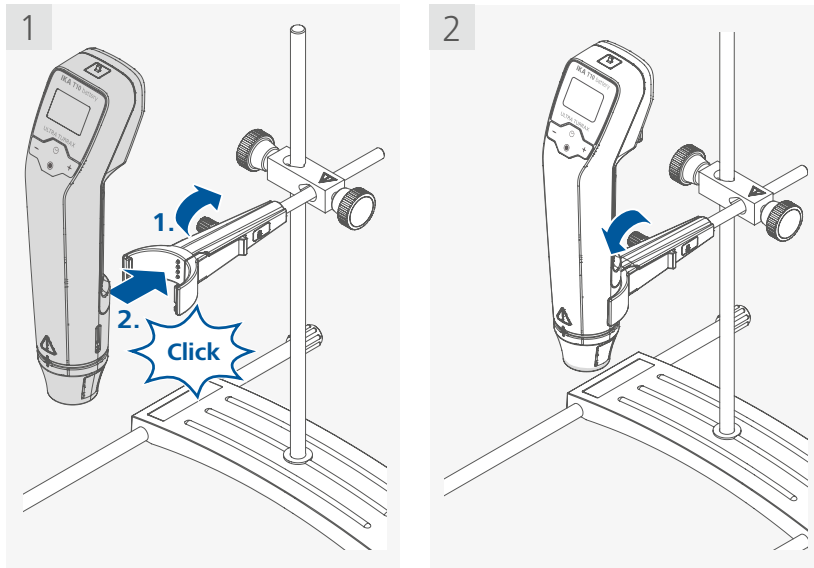

⚠ Notice!

- › After attaching the device to the **R 200 C** terminal, make sure that it is correctly aligned.
- › In order to increase the stability of the mechanical structure, the device must be installed as closely as possible to the stand support rod.

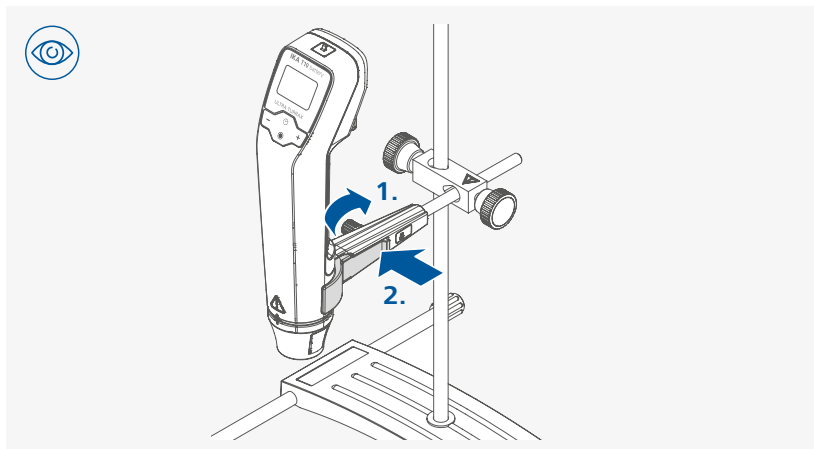

- i**
- › For the disassembly of the device from the clamp, loosen the turning handle on the clamp firstly.
 - › Hold the device with a hand and pressure the locking lever with the other hand.

/// Securing the dispersing tool

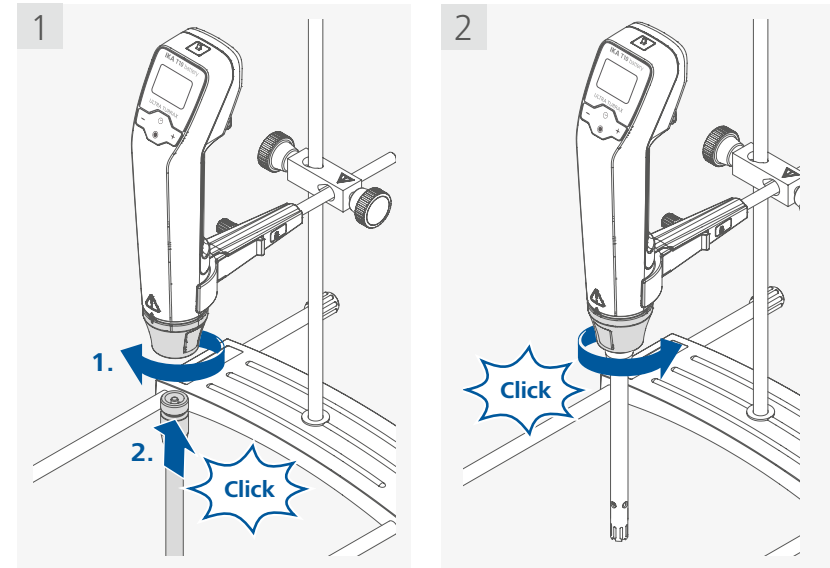

⚠ Notice!

- › Make sure that the dispersing tool is inserted up to the rear stop before you turn the locking mechanism.

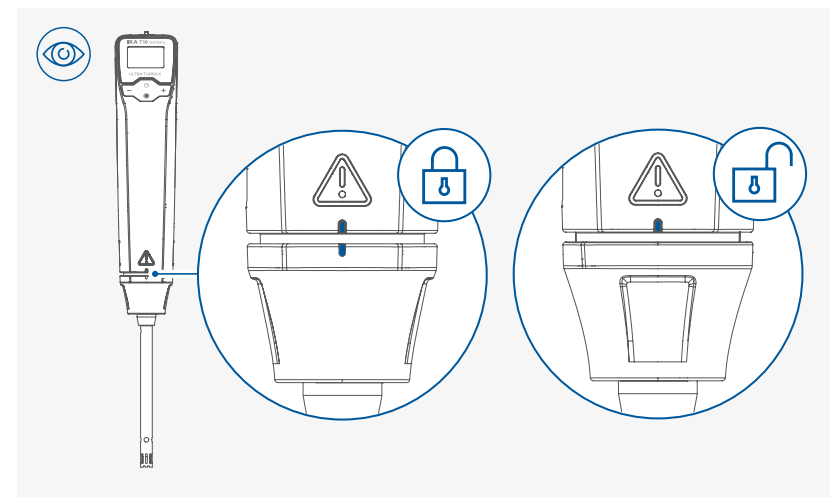

⚠ Notice!

- › Pay attention to the lock/unlock status of the dispersing tool.

/// Positioning the device

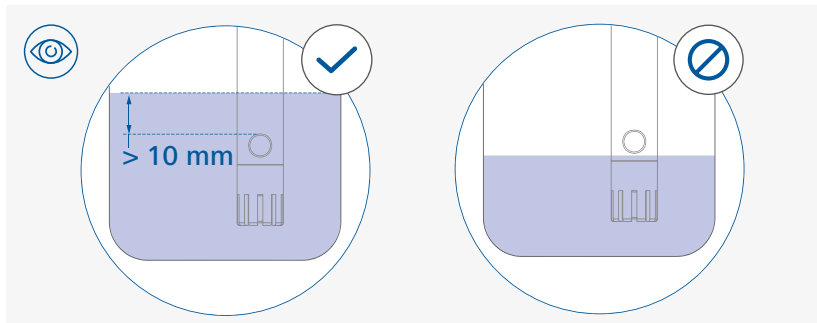
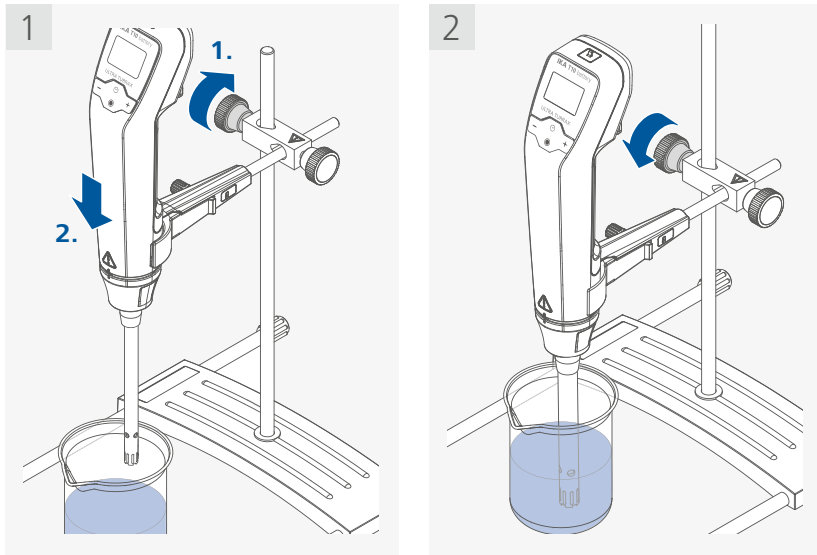

⚠ Notice!

The filling level of the medium must be at least 10 mm above the lower overflow hole of the shaft.

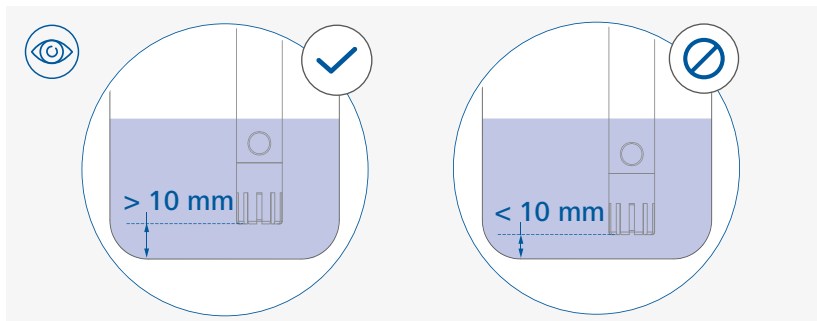

⚠ Notice!

The distance between the dispersing tool and the vessel bottom should not be less than 10 mm.

/// Attaching the exchangeable adapter as necessary

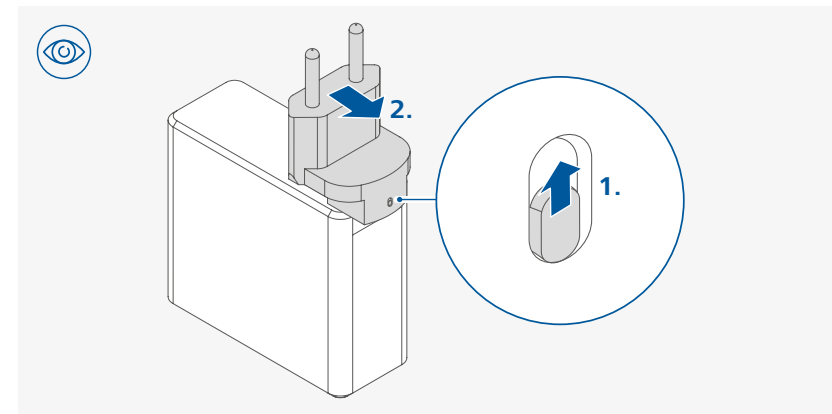
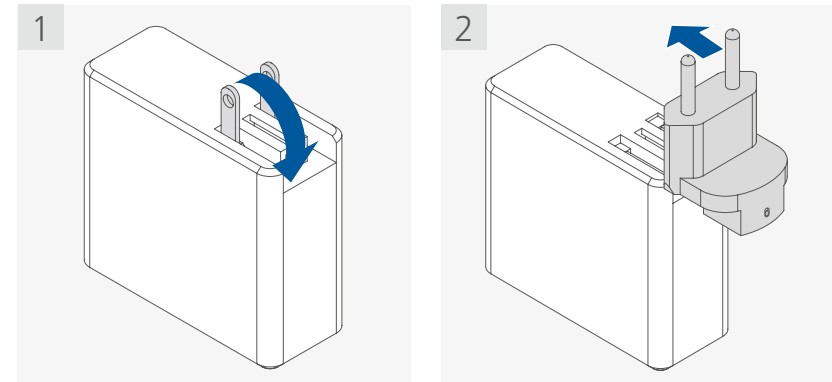

i For removing the exchangeable adapter, push the latch upward firstly.

/// Connecting to the power / charging the battery pack

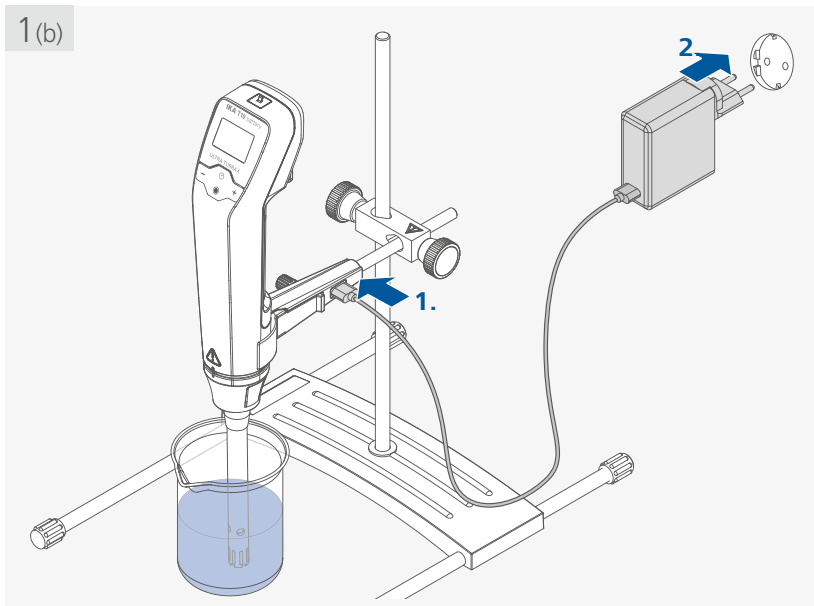
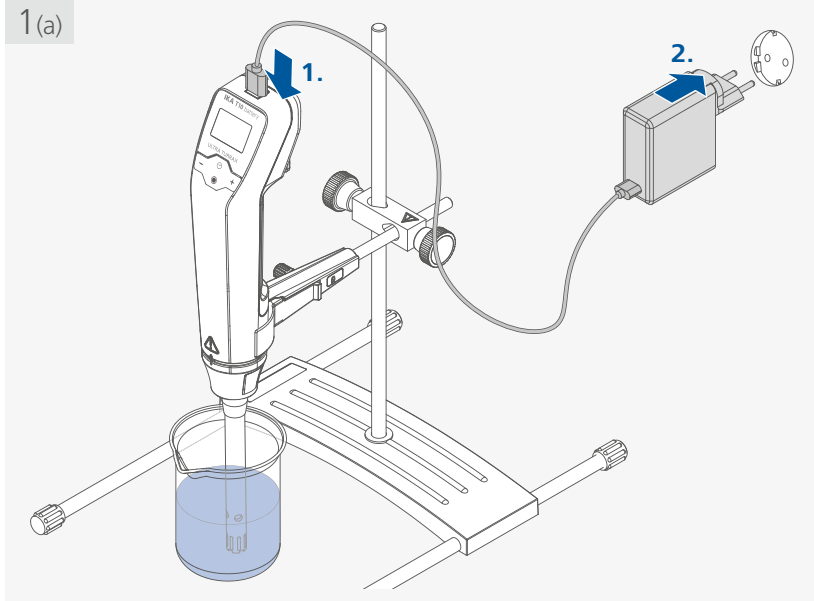

⚠ Notice!

- › The device must only be operated with the original power supply unit and the original USB (C-C) cable.
- › The built-in battery can only be charged when the device is switched on with the slide switch (A) and meanwhile the device is not running.
- › It is not possible to charge the battery by connecting the USB cable to a computer.

Operator panel and display

/// Explanation of the control elements

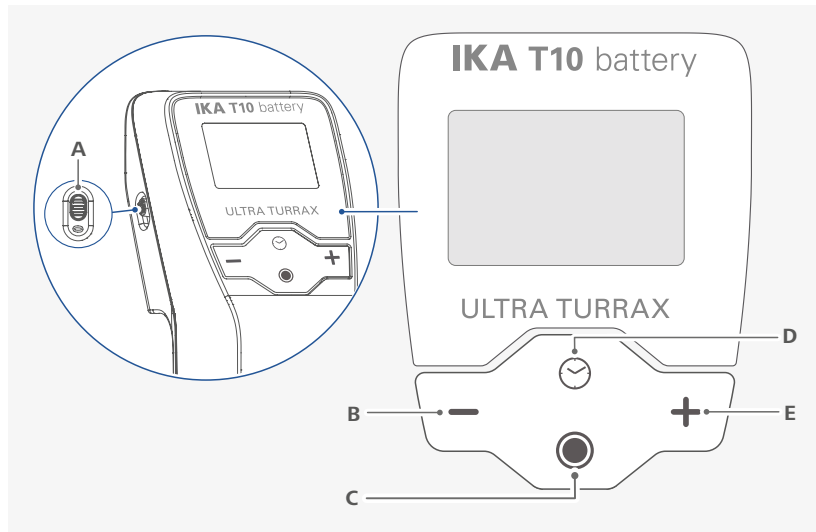

A	Slide switch (0/1)	Switch the device on (1) or off (0).
B	Minus (-) button	Decrease the set value (speed/timer).
C	Start/stop button	Start/stop the device function. Confirm the menu setting.
D	Multifunction button	Switch between different device functions: - Counter/Timer - Device information.
E	Plus (+) button	Increase the set value (speed/timer).

/// Explanation of symbols on the working screen

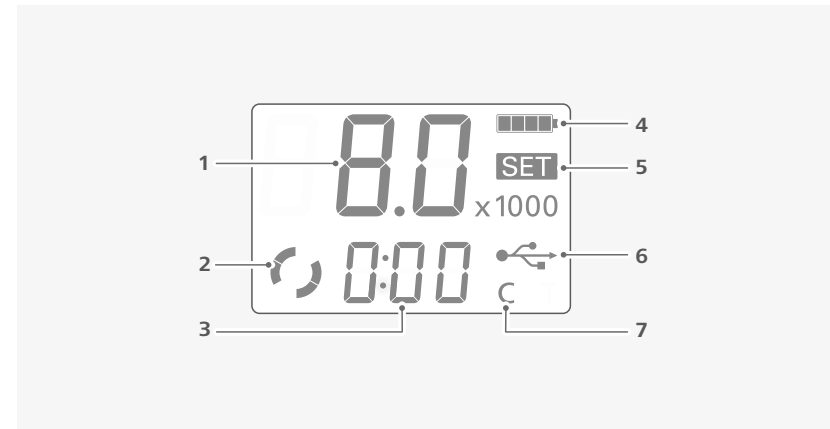

1	Speed display	Display the speed value (x1000 rpm).
2	Working symbol	Indicate the device function is activated.
3	Counter (C)/Timer (T) display	Indicate the "Counter/Timer" value.
4	Battery symbol	Indicate the battery status.
5	"SET" symbol	Indicate the set value is displayed.
6	USB connection symbol	Indicate a USB cable is connected.
7	Counter (C) / Timer (T) symbol	Indicate the "Counter" or "Timer" is activated.

i The symbols displayed change depending on the status and settings of the device.



Operation

⚠ Notice!

Observe the ambient conditions (temperature, humidity etc.) listed under "Technical Data".

/// Switching on the device

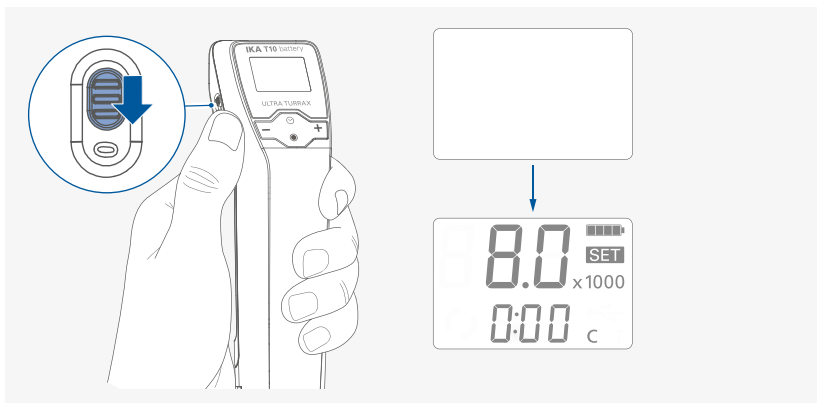

/// Setting the speed

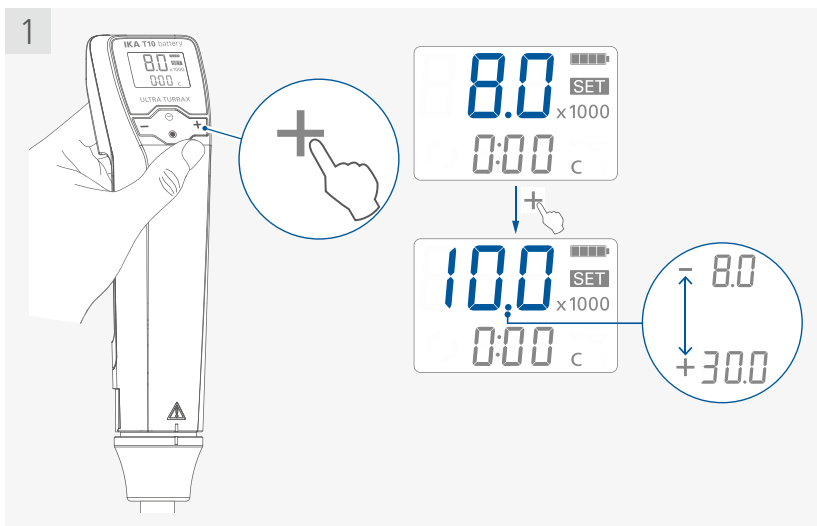

/// Starting the device function

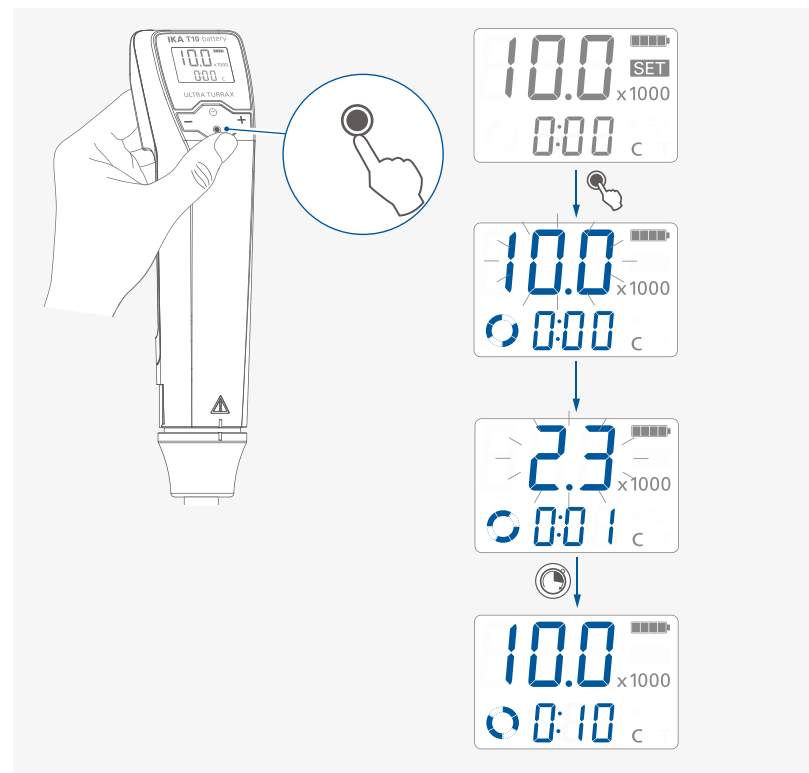

/// Stopping the device function

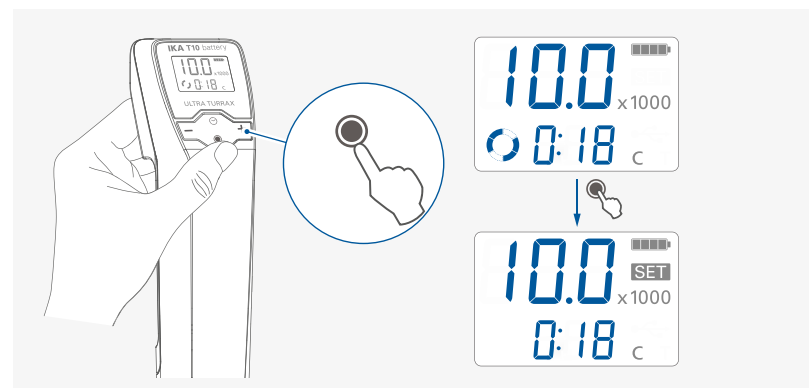

- › After stopping the device function, the last speed setting is shown on the display.
- › After stopping the device function, the elapsed running time (counter value) or the last set timer value is displayed.
- › If the device is not running and no button is pressed for 2 minutes, the display will turn off and the device will go into standby mode. Even during a malfunction, the standby mode will be activated. Only switching the device off and on again via the slide switch (A) will solve the error.
- › The standby mode is sufficient to minimize the battery discharge in daily life.
- › The device switches from standby mode back to operating mode by pressing any button.
- › To keep the battery discharge as low as possible, switch off the device using the slide switch (A) when it is not in use for a long time.
- › After switching on the device via the slide switch (A), the minimum speed is set to 8000 rpm (8.0) and the counter value is set to 0:00.

Menu navigation and structure



/// Menu navigation

- › Activate the editing of menu option by pressing multifunction button (D).
- › Activate the editing of next menu option by pressing multifunction button (D) again.
- › Current selected menu option blinks.
- › Change the desired menu option (Counter/Timer) by pressing and pressing the plus (+) button (E) or minus (-) button (B).
- › Confirm the setting by pressing the start/stop button (C).

/// Menu structure

	Default settings
Menu — Counter (C)	Activated
Timer (T)	-
Device information (Inf)	-

/// Menu details

Counter (C)/Timer (T):

Setting and confirming the counter/timer value in stopped or operating status:

- › Activating the "Counter/Timer" setting.
- › Set the desired timer value.
- › Confirming the setting.

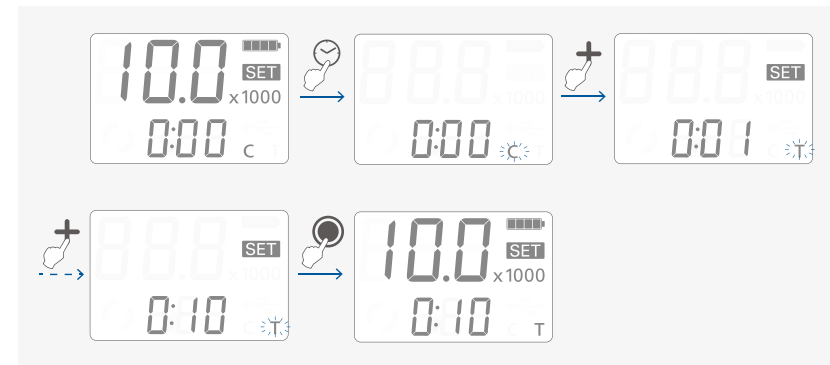

- i** > If the value of the counter/timer setting is set to 0:00 [minute:second], the counter function is activated and the corresponding symbol (7) lights up. When the device function is started, this value automatically starts to run from 0:00 to maximum value 9:59.
- > In counter mode, the display [minute:second] automatically changes to [hours:minutes] after 9:59. This means that 15 minutes will be displayed as 0:15 [hours:minutes].
- > If the value of the counter/timer setting is set to a value larger than 0:00, the timer function is activated and the corresponding symbol (7) lights up. Once the set timer value has elapsed, the device function stops automatically and the last set timer value is displayed. The maximum timer value is 9:59. While the device function is active, the timer setting can be checked by pressing the multifunction button (D) and reset if necessary. The device function can be stopped by pressing the start/stop button (C). This stops the timer and resets it to the last set value.
- > The device is designed for short-term operation max. 10 minutes on / min. 5 minutes off. In counter operation, the operating time is not automatically limited. Depending on the application (load), however, with operating time of more than 10 minutes, a sudden stop of the device and display of an error code due to too high temperature must be expected at any time.

Device information (Inf):

View of the device information in the stopped state:

- > Select the device information menu.
- > Confirm the setting.

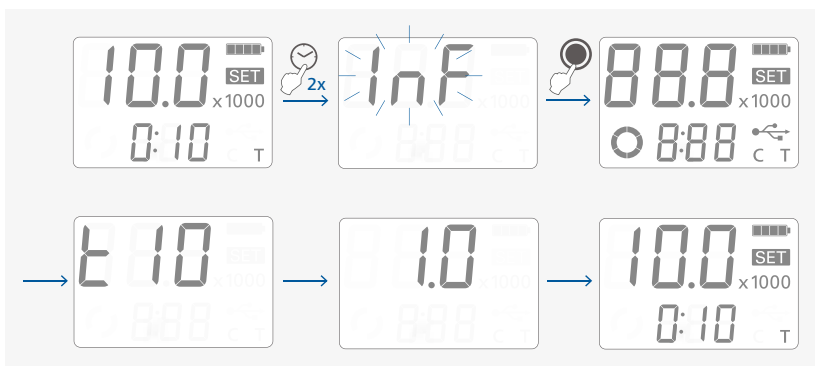

- i** When the device Information setting is active, a self-check screen, the device name, and the software version will appear.

Interfaces and outputs

The device can be operated in "Remote" mode via the USB port connected to a PC and with the laboratory software Labworldsoft®.

The device software can also be updated with a PC via the USB port.

⚠ Notice!

Please comply with the system requirements together with the operating instructions and help section included with the software.

Also note the requirements for the ability to put the device into a safe status in an emergency if it is controlled externally.

/// USB interface

The Universal Serial Bus (USB) is a serial bus for connecting the device to the PC. Equipped with USB devices can be connected to a PC during operation (hot plugging).

Connected devices and their properties are automatically recognized.

/// USB device drivers

Connect the IKA device through the USB data cable to the PC. The data communication is via a virtual COM port. The data communication is via a virtual COM port.

From Windows 10 and onwards the standard Windows USB driver is automatically loaded and a COM port number is assigned (find details in Windows Device Manager: "USB Serial Port (COMxx)"). If you have problems with USB communication, first ask your IT system administrator whether access to the USB interface is restricted for data security reasons.

/// Command syntax and format

The following applies to the command set:

- > Commands are generally sent from the computer to the lab device.
- > The lab device only sends at the computer's request. Even fault indications cannot be sent spontaneously from the lab device to the computer (automation system).
- > Commands are transmitted in capital letters.
- > Commands and parameters including successive parameters are separated by at least one space (Code: hex 0x20).
- > Each individual command (incl. parameters and data) and each response are terminated with CR LF (Code: hex 0x0d hex 0x0A) and have a maximum length of 80 characters.
- > The decimal separator in a number is a dot (Code: hex 0x2E).

The above details correspond as far as possible to the recommendations of the NAMUR working party (NAMUR recommendations for the design of electrical plug connections for analogue and digital signal transmission on individual items of laboratory control equipment, rev. 1.1).

The NAMUR commands and the additional specific IKA commands serve only as low level commands for communication between the device and the PC. With a suitable terminal or communications program these commands can be transmitted directly to the device. The IKA software Labworldsoft®, provides a convenient tool for controlling the device and collecting data under MS Windows.

Commands	Function
IN_NAME	Read device name.
IN_PV_4	Read current speed value.
IN_SP_4	Read rated value.
OUT_SP_4 X (X = 8000 ... 30000)	Adjust the rated speed value to X rpm.
START_4	Start the motor.
STOP_4	Stop the motor.

/// Connections between device and external devices

› Connecting device to a PC

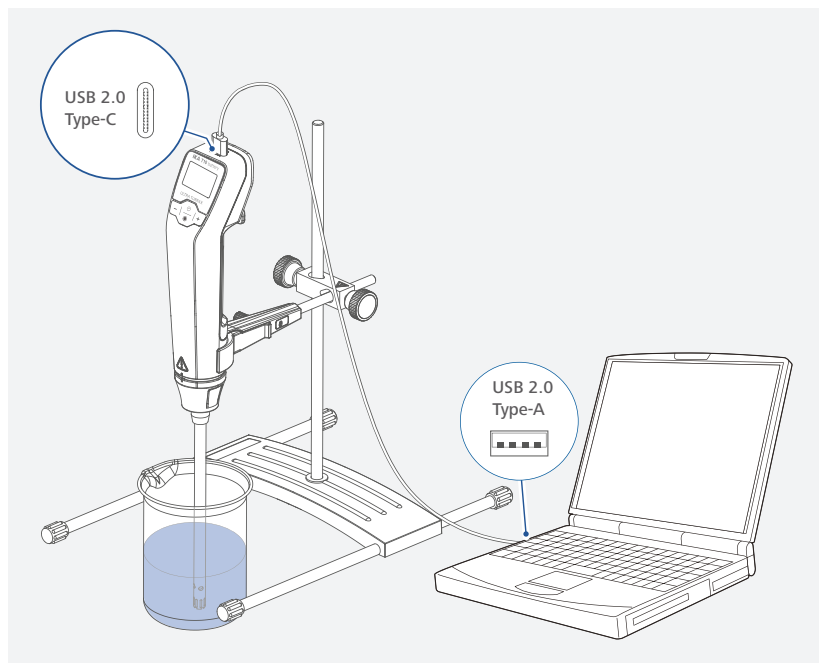

i The USB port on **R 200 C** clamp cannot be used for connecting to a PC for communication.

USB 2.0 Cable (C - C):
This cable is required to connect to the power supply for charging the battery pack.

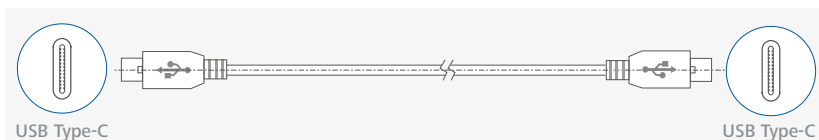

USB 2.0 Cable (A - C):
This cable is required to connect USB interface to a PC.

Note: The USB 2.0 Cable (A - C) is not included in delivery scope.

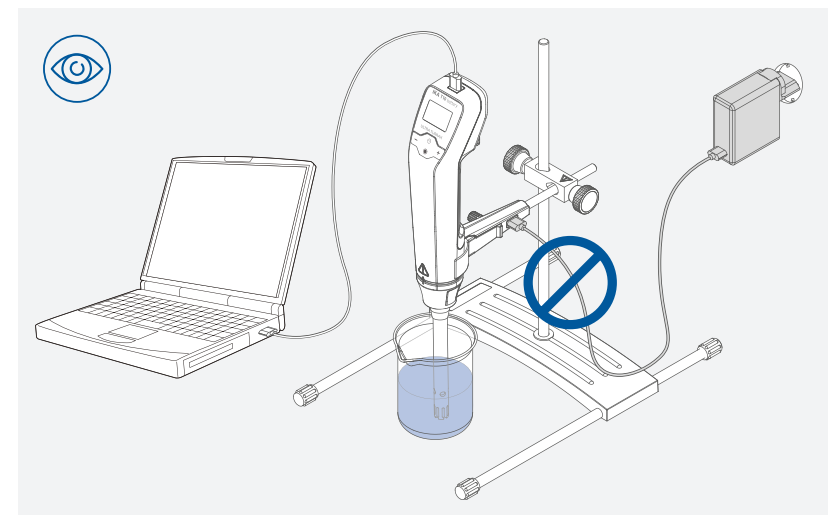
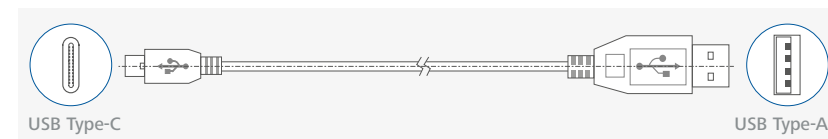

⚠ Notice!
To ensure stable communication between the device and PC, the device must not be connected to the plug-in power supply unit via the terminal on the **R 200 C** clamp.

/// Device software update

Keep your device up-to-date with the IKA Firmware update tool.
The firmware update can be done with a computer connected through USB-Interface.
For this, you need register on our website MyIKA first.
After registering your device IKA will inform you about available updates for your devices. Please download the software "FWUToolSetup.zip" from our IKA service website.

Maintenance and cleaning

The device is maintenance-free. It is only subject to the natural wear and tear of components and their statistical failure rate.

/// Cleaning

For cleaning disconnect the mains plug!

Use only cleaning agents which have been approved by IKA to clean the devices:

Water containing surfactant / isopropyl alcohol.

- › Wear protective gloves during cleaning the devices.
- › Electrical devices may not be placed in the cleansing agent for the purpose of cleaning.
- › Do not allow moisture to get into the device when cleaning.
- › Before using another than the recommended method for cleaning or decontamination, the user must ascertain with IKA that this method does not destroy the device.

/// Ordering spare parts

When ordering spare parts, please indicate:

- › Device type.
- › Serial number, see type plate.
- › Item and designation of the spare part, see spare parts diagram and spare parts list.

/// Repairs

Please send in device for repair only after it has been cleaned and is free from any materials which may constitute a health hazard.

For repair, please request the "Decontamination Certificate" from **IKA**, or download printout of it from the **IKA** website.

If you require servicing, return the device in its original packaging. Storage packaging is not sufficient. Please also use suitable transport packaging.

Warning message

Low battery:

Warning message	› Empty battery icon flashes every 0.5 second:
	
Cause	› Battery level is too low.
Effect	› Error code E 04624225 will appear when the battery exhausted.
Solutions	› Stop the device. › Charge the battery.

The battery capacity declined too much:

Warning message	› Bad battery message appear on the display:
	
Cause	› The battery capacity declined too much.
Effect	› The battery depletes fast.
Solutions	› Stop and switch off the device. › Send the device for replacing the battery pack.

i The bad battery message can be temporarily eliminated by pressing and holding the "+" and "-" button at the same time.

Error codes

Any malfunctions during operation will be identified by an error message on the display.

Proceed as follows in such cases:

- › Switch off the device with the slide switch (A).
- › Carry out corrective measures.
- › Restart the device.

i In case of a failure, press the control knob or start/stop button for 1 seconds to show the full error code.

Error code | Causes | Effect | Solutions

E24: Motor

04243610 - Motor speed blocked

Causes	› Motor can't run normal (can't start or not reach the target speed).
Effect	› Motor off
Solutions	› Switch off the device. › Check the structure for possible blockage.

04243806 - Motor temperature set value exceeded

Causes	› Motor temperature is too high.
Effect	› Motor off
Solutions	› Switch off the device. › Let the device to cool down.

E41: Internal temperature

04411702 - Internal temperature upper limit exceeded

Causes	› Inside temperature is too high.
Effect	› Motor off
Solutions	› Switch off the device. › Let the device to cool down.

E62: Battery

04624225 - Battery voltage too low

Causes	› Battery voltage is too low.
Effect	› Motor off
Solutions	› Switch off and restart the device again. › Charge the battery.

04623824 - Battery temperature too high

Causes	› Battery temperature is too high
Effect	› Motor off
Solutions	› Switch off the device. › Check the ambient temperature and let the device cool down.

04624204 - Battery voltage permitted deviation exceeded

Causes	› Battery is damaged or aged.
Effect	› Motor off
Solutions	› Switch off the device. › Send the device for replacing the battery pack.

If the actions described fails to resolve the fault or another error code is displayed then take one of the following steps:







- › Contact the service department.
- › Send the device for repair, including a short description of the fault.

Accessories

R 104	Stand
R 182	Cross sleeve
H 44	Cross sleeve

See more accessories on www.imlab.eu

Permitted dispersing tools

Designation		Material of shank
S 10 N - 5 G		Stainless steel
S 10 N - 8 G		Stainless steel
S 10 N - 10 G		Stainless steel
S 10 N - 8 G ST		Stainless steel
S 10 N - 10 G ST		Stainless steel
S 10 D - 7 G - KS - 65		Synthetic material
S 10 D - 7 G - KS - 110		Synthetic material

For applications and further information, please see the operating instructions of the dispersing tools.
Only use the dispersing tools listed and observe the operating instructions of the dispersing tool.



Technical data

Motor rating input	W	30
Motor rating output	W	25
DC voltage	VDC	15
Current consumption	mA	3000
Volume range (H ₂ O)	l	0.0005 ... 0.1
Maximum viscosity	mPa·s	200
Speed range	rpm	8000 ... 30000
Speed deviation		± 5 % of current speed
Speed display		LCD
Speed adjustment		Stepless
Noise without dispersing tool	dB (A)	≤ 65
Counter/Timer function		Yes
Max. Counter/Timer		10 minutes (9:59 [minute:second])
Time display		LCD
Permitted on-time		ON: max. 10 minutes / OFF: min. 5 minutes
Dimension (W x D x H)	mm	53 x 70 x 239
Weight	kg	0.5
Permissible ambient temperature	°C	+ 5 ... + 40
Permissible relative humidity	%	80
Drive		Brushless DC motor
IP code according to EN 60529		IP 30
Interface		USB type C
Operation at a terrestrial altitude	m	max. 2000

Battery pack

Voltage	VDC	10.8
Charging capacity	mAh	3200
Battery type		Li-ion battery pack

Power supply

Input		100 ... 240 VAC 0.8 A 50 ... 60 Hz
Output		5 VDC – 3.0 A 9 VDC – 3.0 A 12 VDC – 3.0 A 15 VDC – 3.0 A 20 VDC – 3.25 A
Total power output		65 W (Max.)
Protection class		II (double insulated)

Subject to technical changes!

Warranty

In accordance with IKA Terms and Conditions of Sale, the warranty period is 24 months. For claims under the warranty please contact your local dealer. You may also send the machine direct to our factory, enclosing the delivery invoice and giving reasons for the claim. You will be liable for freight costs.

The warranty does not cover worn out parts, nor does it apply to faults resulting from improper use, insufficient care or maintenance not carried out in accordance with the instructions in this operating manual.