

KERN[®] *KERN & Sohn GmbH*

Montageanleitung Auffahr-Rampe
Instruction of Assembly Access Ramp
Instruction de montage Rampe de montée
Instrucción de montaje Rampa de subida
Istruzione di montaggio Rampa d'accesso
Montageaanwijzing Oprijplaat
Instrukcja montażu Rampa najazdowa
Montážní instrukce Nájezdová rampa
Инструкция по монтажу Подъездная аппарель
Instrução de montagem Rampa de acesso

KERN BIC- A01 / A02 / A03

Version 1.0

09/2016

D-GB-F-E-I

NL-PL-CZ- P

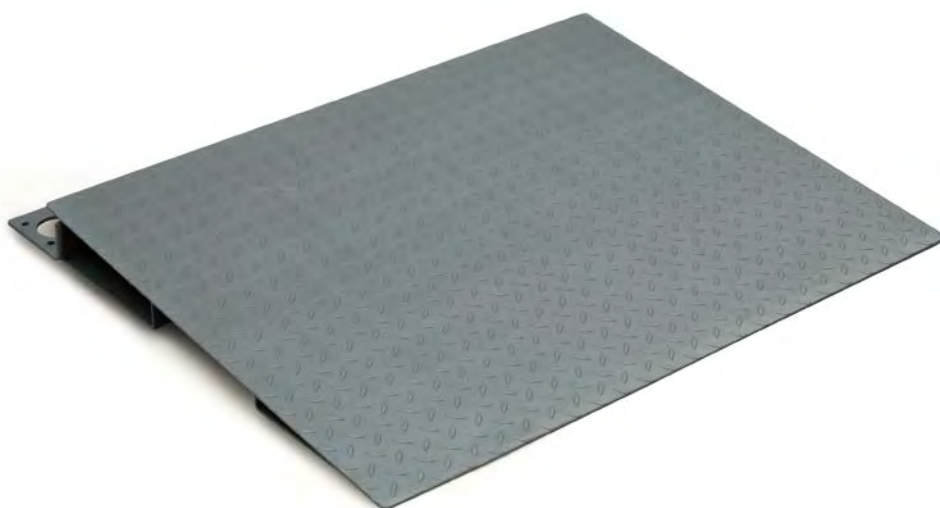

BIC- A01 / A02 / A03-IA-multi-1610

KERN®

D Abbildung ähnlich GB Figure approximately F Figure d'environ
 E Figura aproximadamente I Figura circa NL Figuur ongeveer PL Rysunek około
 CZ Obrázek přibližně P Figura aproximadamente

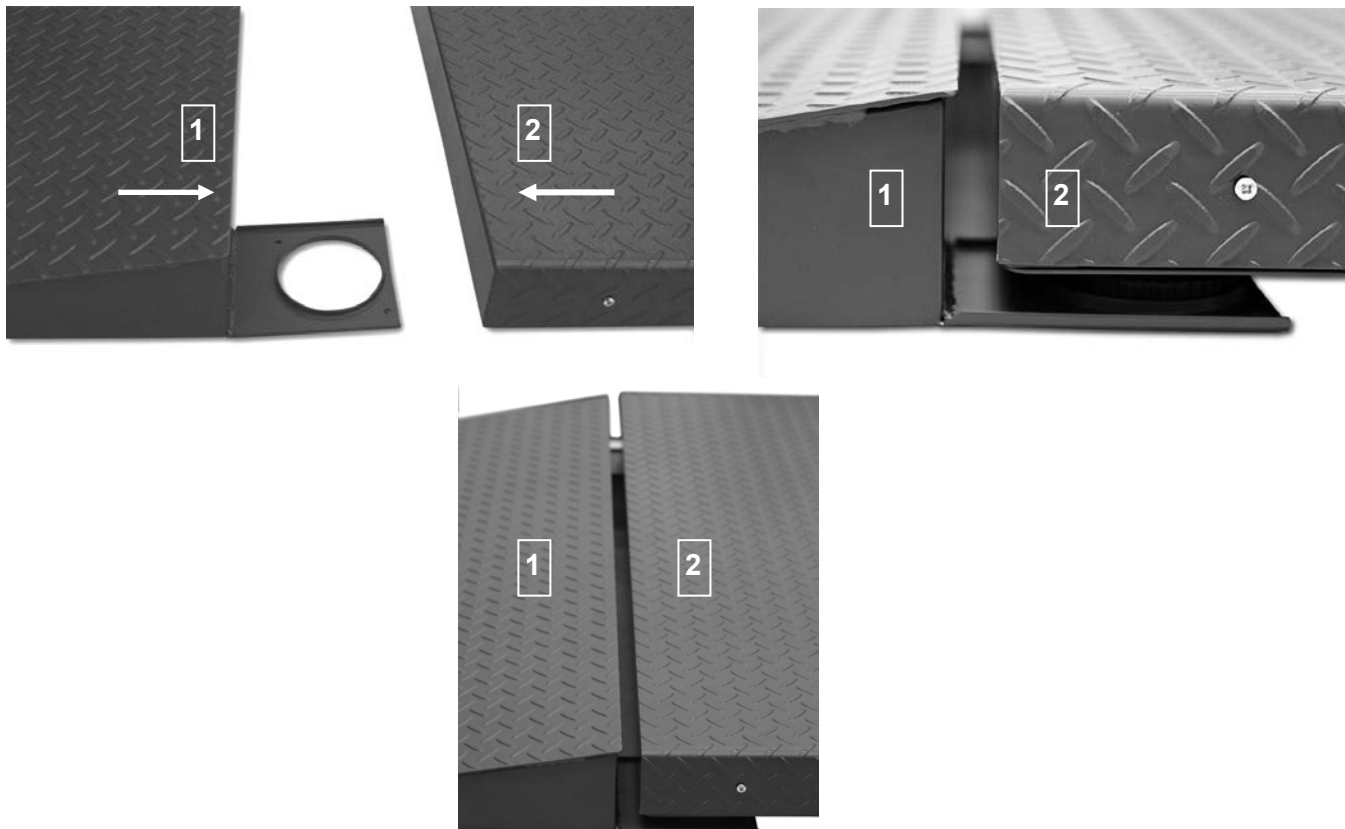

	1	2
D	Auffahr-Rampe	Wägebrücke
GB	Access ramp	Platform
F	Rampe	Pont de bascule
E	Rampa	Puente de báscula
I	Rampa d'accesso	Ponte della bilancia
NL	Oprijplaat	Weegschaalplatform
PL	Rampa najazdowa	Pomost wagi
CZ	Rampa	Můstek
RUS	Подъездная аппарель	Грузоприемное устройство
P	Rampa de acesso	Ponte de pesagem

BIC-A01

D	Maße (mm)	B x T x H 1000x1000x107
GB	Dimensions	S x G x W 1000x1000x107
F	Dimensions	S x G x W 1000x1000x107
E	Dimensiones	S x G x W 1000x1000x107
I	Dimensione	L x G x A 1000x1000x107
NL	Afmetingen	S x G x W 1000x1000x107
PL	Wymiary	S x G x W 1000x1000x107
CZ	Rozměr	Š x H x V 1000x1000x107
RUS	Размеры	Ш x Г x В 1000x1000x107
P	Medidas	L x P x A 1000x1000x107

BIC-A02

D	Maße (mm)	B x T x H 1200x1000x108
GB	Dimensions	S x G x W 1200x1000x108
F	Dimensions	S x G x W 1200x1000x108
E	Dimensiones	S x G x W 1200x1000x108
I	Dimensione	L x G x A 1200x1000x108
NL	Afmetingen	S x G x W 1200x1000x108
PL	Wymiary	S x G x W 1200x1000x108
CZ	Rozměr	Š x H x V 1200x1000x108
RUS	Размеры	Ш x Г x В 1200x1000x108
P	Medidas	L x P x A 1200x1000x108

BIC-A03

D	Maße (mm)	B x T x H 1500x1000x108
GB	Dimensions	S x G x W 1500x1000x108
F	Dimensions	S x G x W 1500x1000x108
E	Dimensiones	S x G x W 1500x1000x108
I	Dimensione	L x G x A 1500x1000x108
NL	Afmetingen	S x G x W 1500x1000x108
PL	Wymiary	S x G x W 1500x1000x108
CZ	Rozměr	Š x H x V 1500x1000x108
RUS	Размеры	Ш x Г x В 1500x1000x108
P	Medidas	L x P x A 1500x1000x108

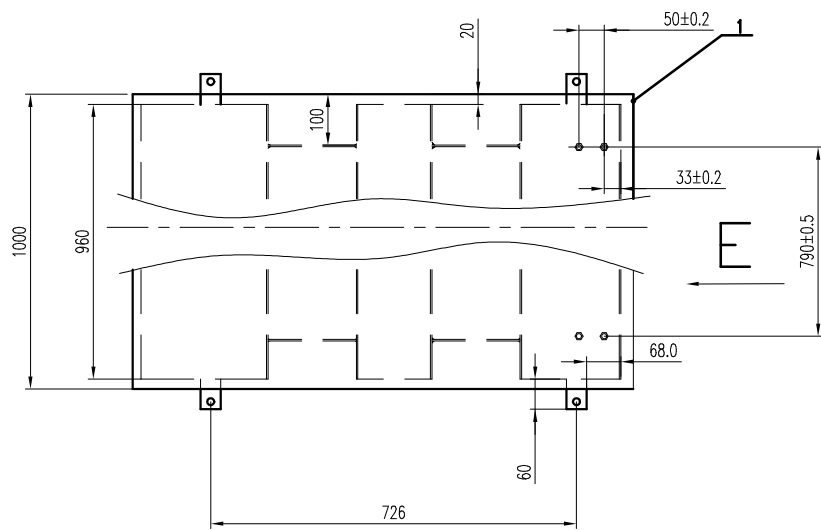
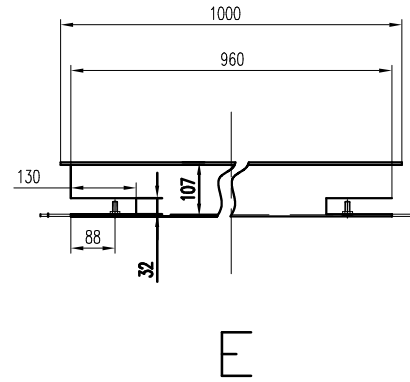
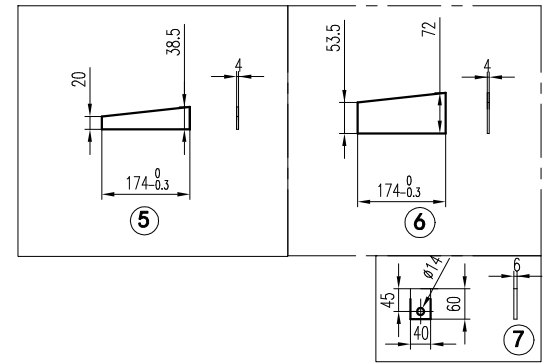
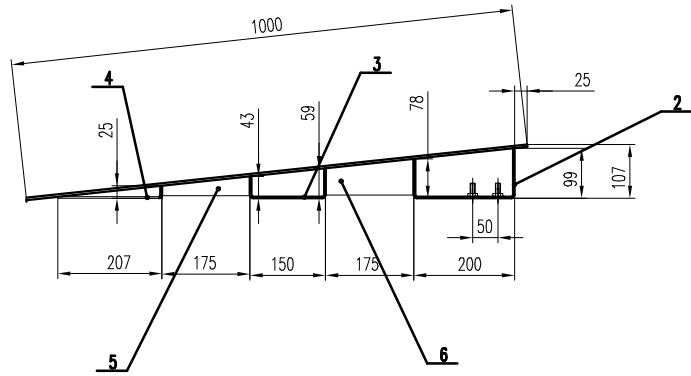

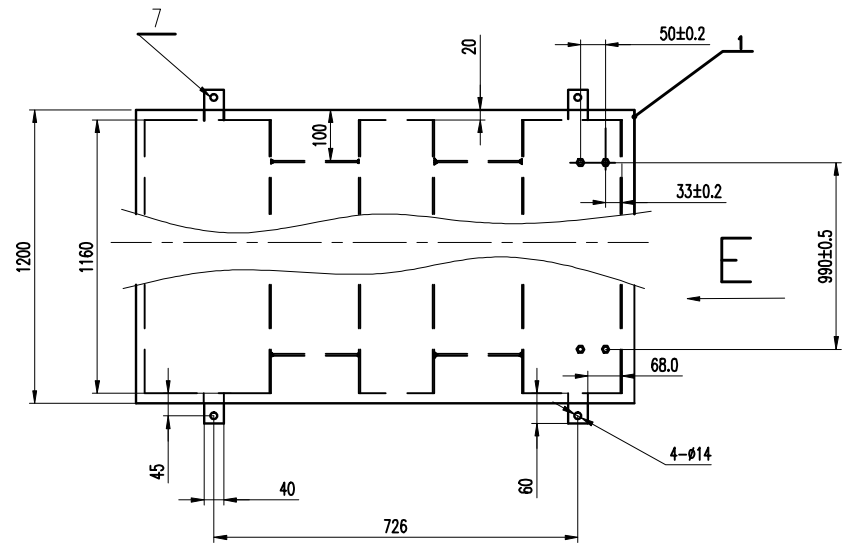
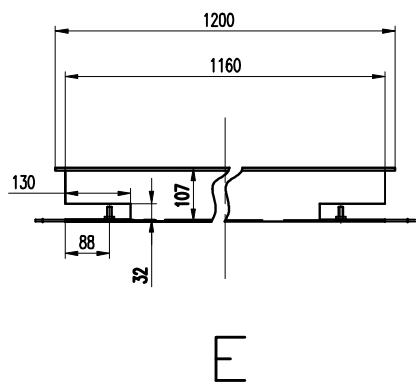
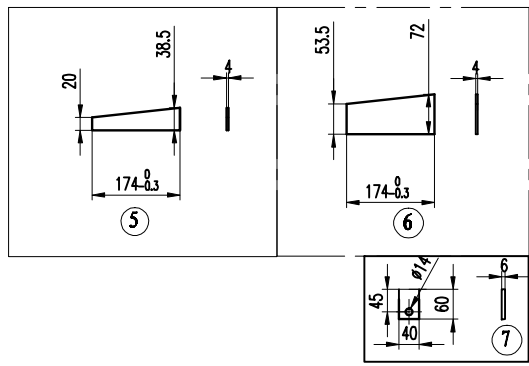
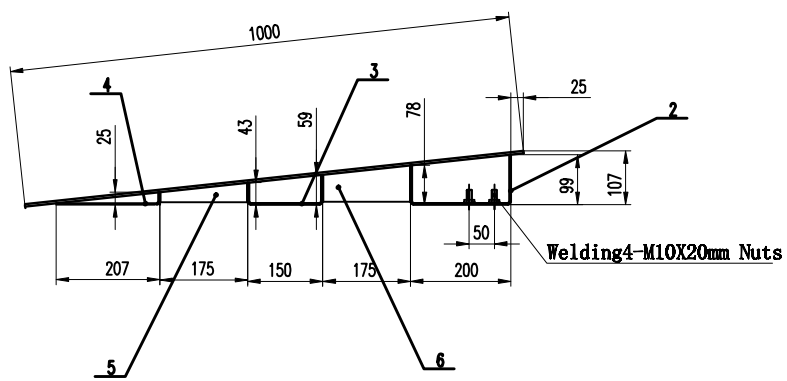

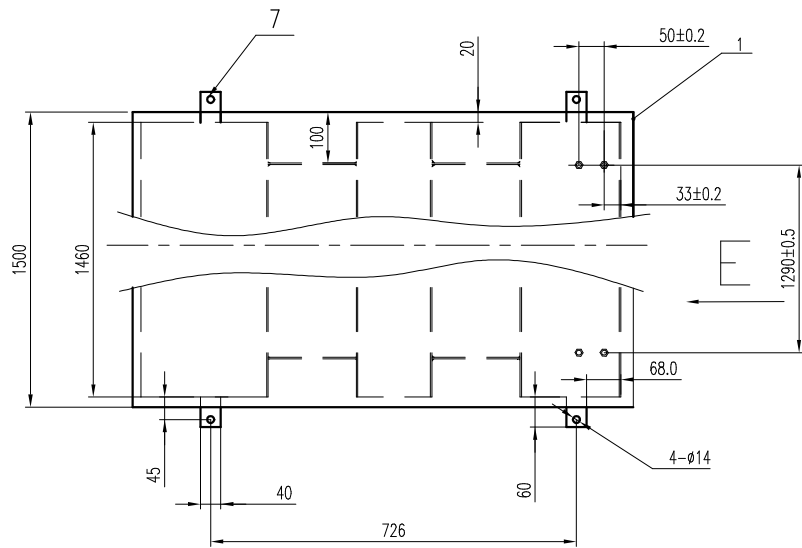
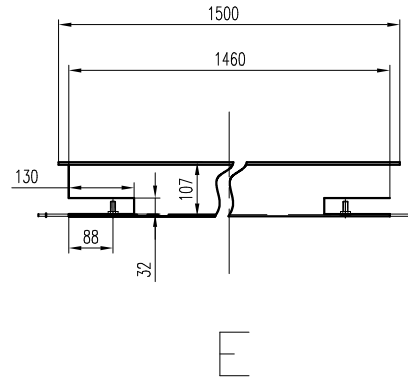
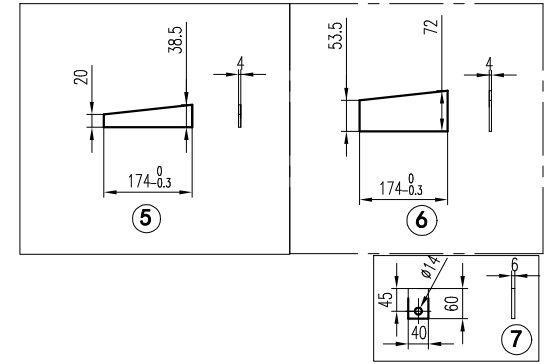
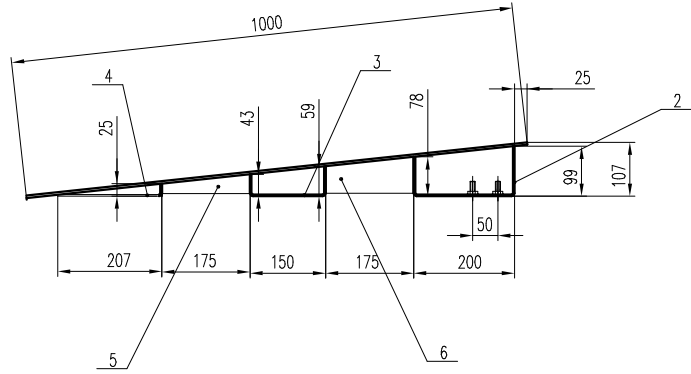

1000x15000