

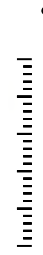

## Transmitted light phase contrast microscope

OBL-14, OBL-15

OBL 146; OBL 156



PROFESSIONAL MEASURING

English version

Operating instructions Transmitted light laboratory microscope

Version 1.3  
2024-09  
en  
OBL-14\_15-BA-en-2413.docx

**KERN  
Optics**

**OBL-14, OBL-15**

**Transmitted light phase contrast microscope**

**Operating instructions Transmitted light laboratory microscope**

Version 1.3 2024-09 English version

Table of contents:

<b>1</b>	<b>Technical data</b> .....	<b>3</b>
<b>2</b>	<b>Declaration of conformity</b> .....	<b>4</b>
<b>3</b>	<b>Overview of the device</b> .....	<b>5</b>
3.1	Nomenclature .....	5
<b>4</b>	<b>Before use</b> .....	<b>9</b>
4.1	General information .....	9
<b>5</b>	<b>Basic information (general)</b> .....	<b>10</b>
5.1	General information on warnings .....	10
5.2	Intended use .....	11
5.3	Improper use .....	11
5.4	Warranty .....	11
<b>6</b>	<b>Basic warnings and safety instructions</b> .....	<b>12</b>
6.1	Observe the notes in the operating instructions .....	12
6.2	Staff training .....	12
6.3	Safety.....	12
<b>7</b>	<b>Transportation and storage</b> .....	<b>15</b>
7.1	Note .....	15
7.2	Transportation .....	15
7.3	Storage .....	15
7.4	Packaging/return transportation .....	15
<b>8</b>	<b>Unpacking and commissioning</b> .....	<b>16</b>
8.1	Unpacking.....	16
8.2	Initial commissioning .....	16
<b>9</b>	<b>Assembly</b> .....	<b>17</b>
9.1	Microscope head .....	17
9.2	Objectives .....	17
9.3	Eyepieces .....	17
9.4	Color filter .....	17
9.5	PH condenser + PH slider .....	18
<b>10</b>	<b>Operation</b> .....	<b>19</b>
10.1	First steps .....	19
10.2	(Pre-) focusing .....	20
10.3	Adjusting the interpupillary distance.....	21
10.4	Dioptr adjustment .....	21
10.5	Adjusting the magnification .....	22
10.6	Adjusting the Koehler illumination .....	23
10.7	Using the eyecups .....	26
10.8	Use of oil immersion lenses .....	27
10.9	Phase contrast unit.....	28

<b>11</b>	<b>Lamp replacement ( LED) .....</b>	<b>30</b>
<b>12</b>	<b>Use of optional accessories r .....</b>	<b>31</b>
12.1	Camera connection (OBL 156).....	31
<b>13</b>	<b>Troubleshooting .....</b>	<b>32</b>
<b>14</b>	<b>Service .....</b>	<b>35</b>
<b>15</b>	<b>Power supply .....</b>	<b>36</b>
15.1	Mains connection.....	36
<b>16</b>	<b>Maintenance, servicing and disposal.....</b>	<b>37</b>
16.1	Cleaning .....	37
16.2	Maintenance and repair.....	37
16.3	Waste disposal .....	38
<b>17</b>	<b>Further information .....</b>	<b>39</b>

## 1 Technical data

<b>Kern model</b>	<b>OBL 146</b>	<b>OBL 156</b>
<b>Item number/type</b>	TOBL 146-A	TOBL 156-A
<b>Dimensions (WxDxH)</b>	395x200x380 mm	394x185x377 mm
<b>Tubus Art</b>	Binocular	Trinocular
<b>Optical system</b>	Infinity	
<b>Revolving nosepiece screw-in positions</b>	4	
<b>Lens quality</b>	Infinity E-Plan / Plan	Infinity E-Plan / Plan
<b>Standard objectives</b>	4x 100x PH 10x PH 40x	
<b>Eyepiece field width</b>	HWF	
<b>Illuminance Transmitted light</b>	3W	
<b>Type of lighting Transmitted light</b>	LED	
<b>Lighting equipment</b>	Transmitted light	
<b>Condenser type</b>	Phase contrast	
<b>Condenser aperture</b>	1,25	
<b>Input voltage power supply / current [ Max ]</b>	100 - 240V AC 50/60Hz 0.3A	
<b>Input voltage device / current [ Max ]</b>	5V, 1A	
<b>Plug-in power supply type</b>	Plug-in power supply	
<b>Fuse</b>	-	
<b>Focusing mechanism</b>	Coaxial coarse and fine drive	
<b>Packaging dimensions</b>	546x380x280 mm	420x275x450 mm
<b>Net weight</b>	5.988 kg	5.488 kg
<b>Gross weight</b>	9 kg	8 kg

## **2 Declaration of conformity**

The current EC/EU Declaration of Conformity can be found online at:  
<https://www.kern-sohn.com/shop/de/DOWNLOADS/>

### 3 Overview of the device

#### 3.1 Nomenclature

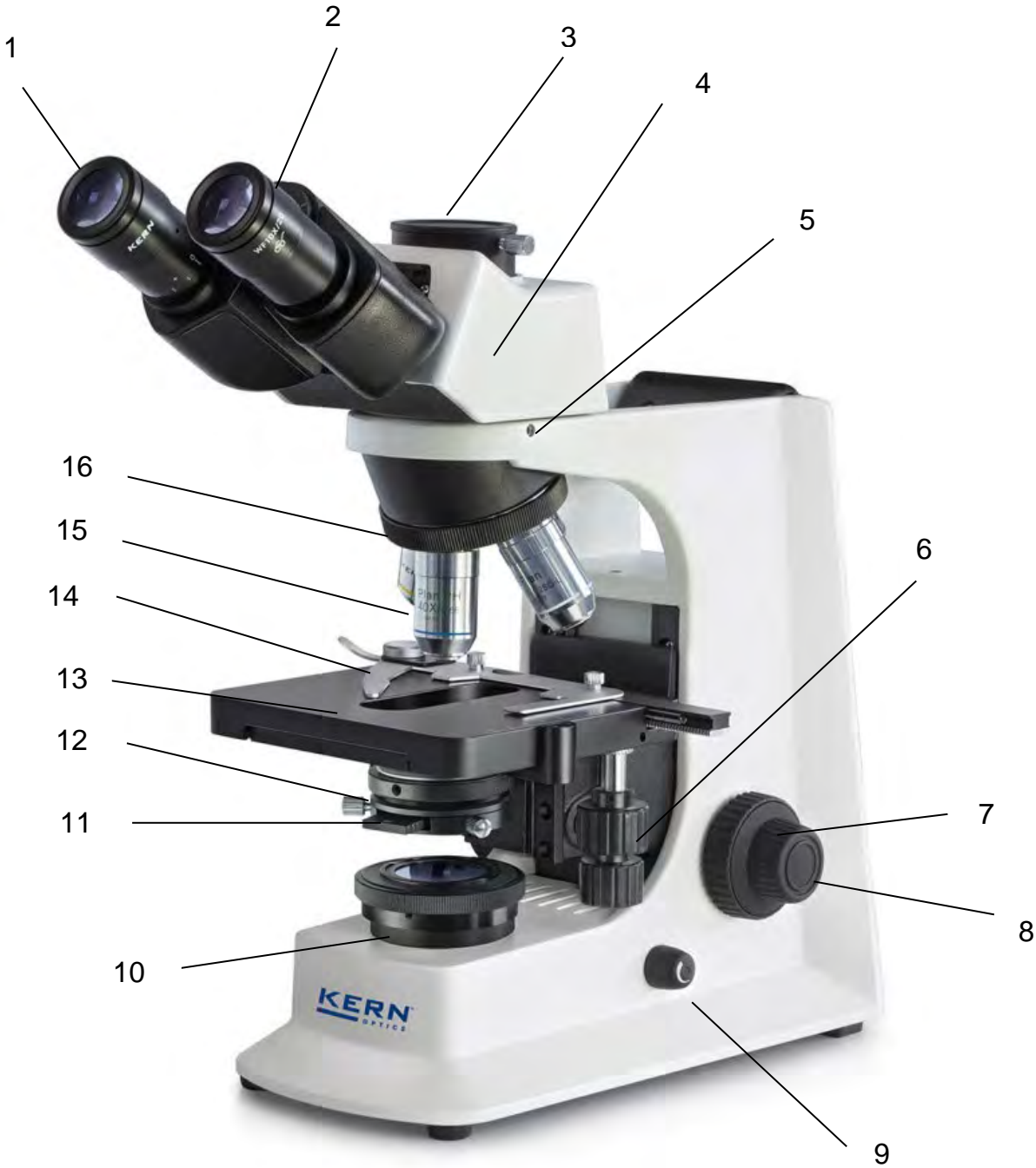

	Description
1	Eyepieces
2	Lens barrel
3	Camera adapter connection with locking screw
4	Microscope head / tube
5	Adjusting screw head
6	Setting wheel x - y axis Object table
7	Coarse adjustment knob
8	Fine adjustment knob
9	Dimmer+ Main switch
10	Field lens with Field diaphragm
11	PH slide
12	PH condenser
13	Specimen stage
14	Object holder
15	Objective
16	Nosepiece

Rear view

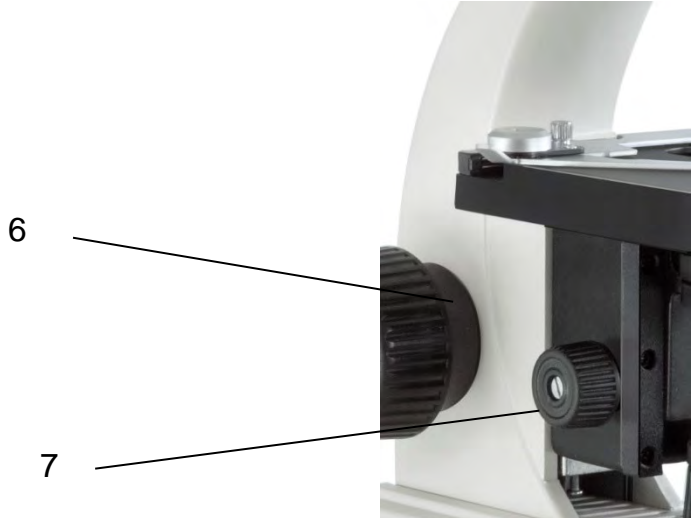
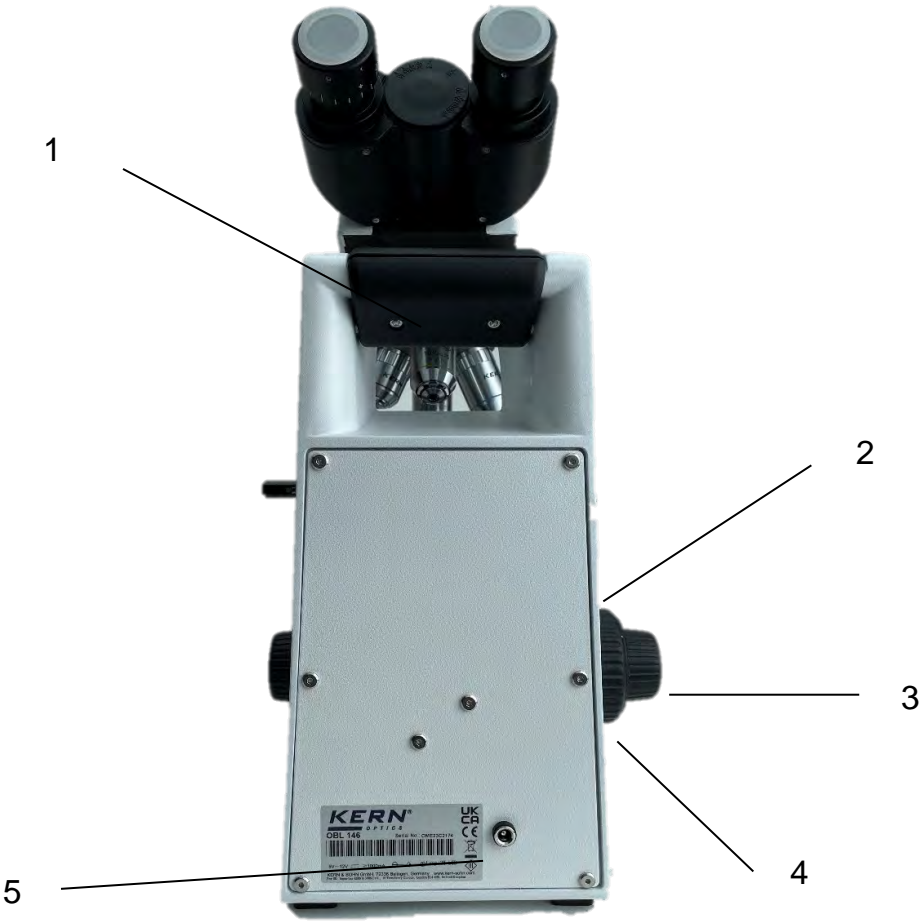

	Description
1	Carrying handle
2	Adjustment ring Torque
3	Fine adjustment knob
4	Coarse adjustment knob
5	Mains connection
6	Adjustment ring Torque
7	Condenser Focus dial

## **4 Before use**

### **4.1 General information**

The packaging must be opened carefully to prevent the accessories inside from falling to the floor and breaking.

In general, a microscope should always be handled with great care, as it is a sensitive precision instrument. Avoiding abrupt movements during operation or transportation is therefore particularly important, especially to avoid endangering the optical components.

You should also avoid dirt or fingerprints on the lens surfaces, as in most cases this impairs the sharpness of the image.

If the performance of the microscope is to be maintained, it must never be disassembled. Parts such as objective lenses and other optical components should therefore be left as they are at the start of operation.





## 5 Basic information (general)

### 5.1 General information on warnings

Warnings are used in these operating instructions to warn you of possible personal injury or damage to property in certain situations.

Signal word	Description
<b>DANGER</b>	Failure to observe the instructions will lead directly to serious injury, permanent impairment (e.g. loss of a limb) or death of the user or third parties
<b>WARNING</b>	Failure to observe the instructions may result in serious injury, permanent impairment (e.g. loss of a limb) or death of the user or third parties
<b>CAUTION</b>	Failure to observe the instructions may result in minor injuries or temporary damage to the user or third parties (e.g. minor cuts)
<b>NOTE</b>	Failure to observe the instructions may result in damage to property

#### Symbols in warning notices :

Icon	Meaning
<b>Warning signs</b>	Warning signs warn you of dangers that may lead to personal injury. The symbol indicates the type of hazard.
	Indicates general hazards or a danger point
	Warning of electrical voltage
	Warning of optical radiation
	Warning of explosive substances
	Indicates electrostatic sensitive devices

Icon	Meaning
<b>Commandment sign</b>	Mandatory signs prescribe measures that you must take to avoid personal injury or damage to property. The symbol indicates the necessary actions or objects to prevent damage.
	Indicates a prescribed action

## 5.2 Intended use

The OBL 14 and OBL-15 are specially designed for analyzing very translucent and thin, low-contrast, challenging specimens (e.g. living mammalian cells, bacteria, tissue) in phase contrast.

## 5.3 Improper use

Do not use the device in potentially explosive atmospheres or for measurements in liquids or on live parts.

Unauthorized structural changes, additions and conversions to the appliance are prohibited.

## 5.4 Warranty

Warranty expires with

- Non-compliance with our specifications in the operating instructions
- Use outside the described applications
- Modifying or opening the device
- Mechanical damage and damage caused by media, liquids, natural wear and tear
- Improper set-up or electrical installation
- Improper assembly or electrical installation

## 6 Basic warnings and safety instructions

### 6.1 Observe the notes in the operating instructions



Read the operating instructions carefully before commissioning/using the device, even if you already have experience with KERN devices. Always keep the instructions in the immediate vicinity of the appliance.

### 6.2 Staff training

The appliance may only be used by persons who have read and understood the operating instructions, in particular the chapter on safety.

### 6.3 Safety

<b>⚠ WARNING</b>	
	<p><b>Read all safety information and instructions.</b> Failure to observe the safety information and instructions may result in electric shock, fire and/or serious injury.</p> <p><b>Keep all safety information and instructions for future reference.</b></p> <ul style="list-style-type: none"><li>● The design of the device must not be modified. This can lead to incorrect measurement results, safety defects and destruction of the device</li><li>● Do not operate the appliance in potentially explosive rooms or areas and do not install it there.</li><li>● Do not operate the device in an aggressive atmosphere.</li><li>● Do not immerse the appliance in water. Ensure that no liquids penetrate the inside of the device.</li></ul> <p>The device may only be used in a dry environment and under no circumstances in rain or relative humidity above the operating conditions.</p> <ul style="list-style-type: none"><li>● Protect the device from permanent direct sunlight.</li><li>● Do not expose the appliance to strong vibrations.</li><li>● Do not remove any safety signs, stickers or labels from the device. Keep all safety signs, stickers and labels in a legible condition</li><li>● Do not open the device</li><li>● The lamp generates a lot of heat during operation. Avoid touching the lamp housing during operation and for some time afterwards.</li><li>● Do not operate the device in an aggressive atmosphere</li></ul>

**⚠ WARNING**



**Risk of injury due to electric shock!**

- Risk of short circuit due to penetration of liquids into the housing!
- Do not immerse the appliance or accessories in water. Make sure that no water or other liquids get into the housing.
- Work on electrical components may only be carried out by an authorized specialist company!
- Take care not to twist or kink the mains cable.
- Only use the original adapter supplied

**⚠ WARNING**



**Choking hazard!**

- Do not leave the packaging material lying around carelessly. It could become a dangerous toy for children.
- The appliance is not a toy and does not belong in the hands of children.
  - This appliance can be dangerous if it is used improperly or not as intended by untrained persons! Observe the personnel qualifications!

**⚠ WARNING**



**Electrostatic sensitive device!**

- The device can be destroyed by electrostatic discharges. Connectors for HF signals are particularly at risk.
- Please observe the handling instructions for electrostatically sensitive components.

**⚠ WARNING**



**There is a risk from optical radiation!**

- Gas discharge lamps, LED lights and other white light sources generate intense optical radiation, including UV (ultraviolet), visible light (VIS) and IR (infrared). This radiation can cause both skin and eye damage. The extent of the damage is determined by the wavelength, the duration of exposure and the operating mode (continuous or pulsed).
- Do not expose eyes and skin to radiation.
  - Do not insert any reflective objects into the beam entrance.
  - If necessary, use suitable protective equipment/protective clothing.
  - Never remove the cover or cladding during operation.
  - Never look into the eyepieces when the beam path is open (using the control lever for illumination) and an empty filter position is selected on the FL module. There is an acute risk of blindness here.

## CAUTION

Keep a sufficient distance from heat sources.

Do not use the device in environments with high humidity or water mist

## ! NOTE

- To avoid damaging the device, do not expose it to extreme temperatures, extreme humidity or moisture.
- Do not use harsh cleaners, abrasive cleaners or solvents to clean the appliance.

## **7 Transportation and storage**

### **7.1 Note**

If you store or transport the device improperly, the device may be damaged. Observe the information on transporting and storing the appliance.

### **7.2 Transportation**

We recommend using the original packaging for shipping, transportation or storage of the microscope components. To prevent damage from shocks, all moving parts that can be assembled and disassembled must be packed separately.

### **7.3 Storage**

Avoid exposing the device to direct sunlight, high or low temperatures, shocks, dust and high humidity.

The suitable temperature range is 0 - 40 °C and a relative humidity of 85% should not be exceeded.

The appliance should always be placed on a firm, smooth and horizontal surface.

When the microscope is not in use, it is best to cover it with the dust cover supplied. Dust or dirt inside the optics of a microscope can in many cases lead to irreversible malfunctions or damage.

Accessories consisting of optical elements, such as additional lenses, are preferably stored in a drying box with desiccant.

### **7.4 Packaging/return transportation**

Returns are only possible within the limits of the general terms and conditions. Keep all parts of the original packaging for any necessary return transportation.

- Only the original packaging is to be used for return transportation.
- Disconnect all connected cables and loose/movable parts before shipping.
- Refit any transportation locks provided.
- Secure all parts against slipping and damage.

## **8 Unpacking and commissioning**

### **8.1 Unpacking**



In the event of a return, please observe the instructions in the chapter "Packaging/return transportation"

---

On receipt of the device, you should first check that no damage has occurred during transportation, that the outer packaging, the housing, other parts or even the device itself have not been damaged. If any damage is evident, please notify KERN GmbH immediately.

### **8.2 Initial commissioning**

To ensure the function of the microscope, it must be cleaned as described in chapter 9.

.

## **9 Assembly**

### **9.1 Microscope head**

Inside the packaging the microscope head is already mounted but inclined towards the rear. In order to turn it to the front you must loosen the fixing screw on the tube connection point and after the turning fix it again with the screw. In case of removing the head completely from the housing, you should always make sure that you do not touch the lenses with your bare fingers and that no dust enters the apertures.

### **9.2 Objectives**

The standard equipment of the series OBL-14 and OBL-15 includes two Infintiy E-Plan objectives (4x / 100x) and two Infinity Plan objectives for phase contrast applications (10x / 40x). All four objectives are already mounted to the nosepiece. After removing the protective foil they are ready for use. They are ranged in such a way that if you turn the nosepiece clockwise, the objective with the next higher magnification appears. When the objectives need to be dismounted, you should always make sure that you do not touch the lenses with your bare fingers and that no dust enters the apertures.

For objectives which are marked "OIL", you must use an immersion oil with the lowest level of inherent fluorescence

### **9.3 Eyepieces**

You must always use eyepieces with the same magnification for both eyes. These are simply placed onto the tube connectors, once you have first removed the plastic protective caps. There is no way of fixing them. You should always make sure that you do not touch the lenses with your bare fingers and that no dust enters the apertures.

### **9.4 Color filter**

A blue colour filter is already an integral part of the microscopes of the series OBL-14 and OBL-15. It is fitted underneath the field diaphragm. In order to use suitable filters, these can simply be placed in the ring bracket of the field lens

## 9.5 PH condenser + PH slider

The condenser is firmly fixed onto a holding ring (condenser holder) underneath the microscope stage. There is the ability to adjust the height of the condenser, but not to centre it.

We recommend that you use the coarse adjustment knob to bring the specimen stage to its uppermost position when you need to remove the condenser. Then use the focus dial of the condenser to move the condenser holder to a low position. In this way the condenser can be taken off after loosening the screw on the left side holding ring. You should avoid touching the optical lenses with bare fingers.

To attach a PH slide for phase contrast applications, it just has to be inserted into the appropriate point on the front side of the condenser..

*For further information, see 10.9 Phase contrast unit.*

## 10 Operation

### 10.1 First steps

The first thing to do is to **connect the power supply using the mains plug**. The **light intensity control (dimmer)** should first be set to a **low level so that** the eyes are not immediately exposed to too much light when looking into the eyepieces for the first time. The **lighting** can now be switched on using the **main switch**.

The next step is to **place a slide** with a sample on the stage. The cover glass must be facing upwards for this. The object holder can be used to fix the slide on the stage (see *illustration on the left*). To move the sample into the beam path, the adjustment wheels on the right-hand side of the mechanical stage must be operated accordingly (see *illustration on the right*).

A total of two slides can be placed at the same time.

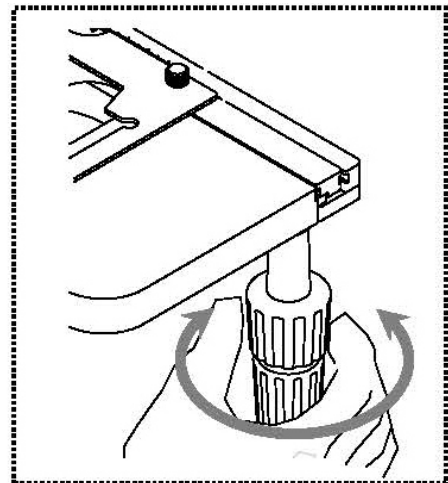
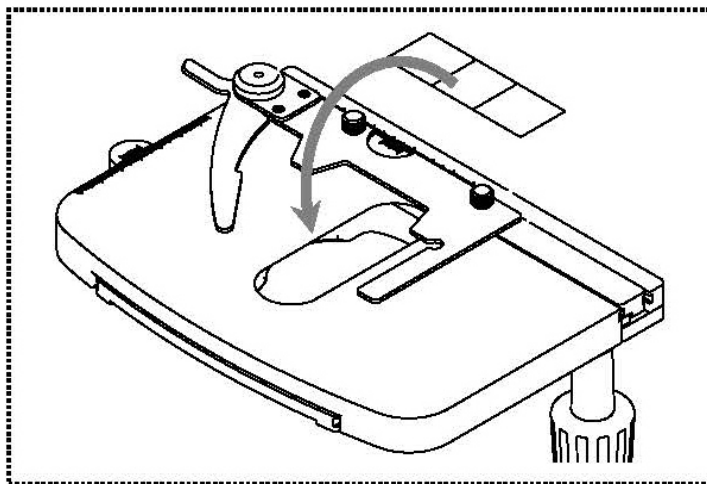

## 10.2 (Pre-) focusing

When you are observing an object, you must have the correct distance to the objective to achieve a sharp image. In order to find this distance at the beginning (without other default settings of the microscope) place the objective with the lowest magnification in the beam path, look through the right eyepiece with the right eye and turn it slowly using the coarse adjustment knob (see illustration).

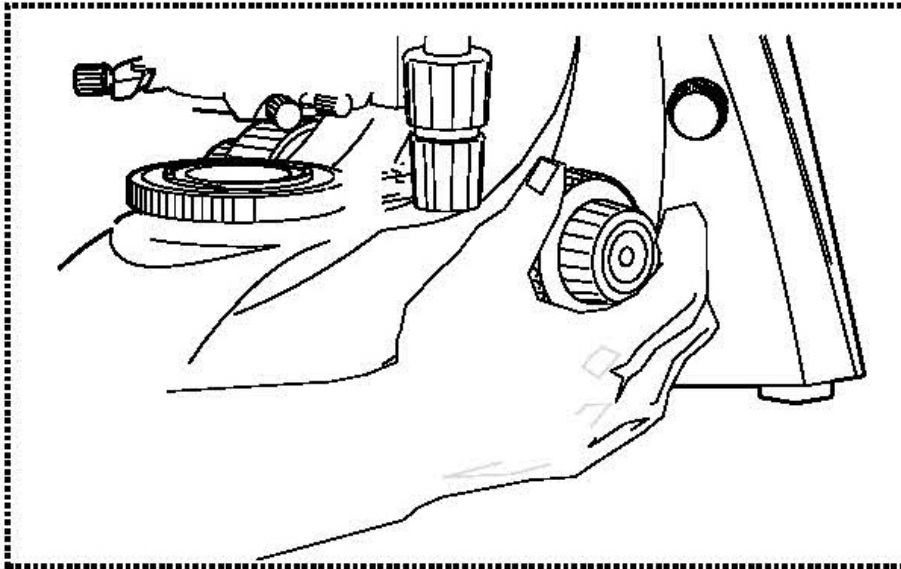

The simplest way of doing this would be to first raise the specimen stage (using the coarse adjustment knob) until it is just under the objective and then lower it slowly. As soon as an image is recognisable (no matter how sharp), then you should only adjust the focus using the fine adjustment knob..

### Adjusting the torque of the coarse and fine adjustment knob

Next to the left adjustment wheel for the coarse and fine adjustment knob there is a ring which you can use to alter the torque of these wheels. Turning it in a clockwise direction reduces the torque and turning it in an anti-clockwise direction increases it. On one hand, this function can help to make it easier to adjust the focus and on the other hand it can prevent the specimen stage from slipping down unintentionally.

### Important

In order to avoid damaging to the focussing system, the left and right adjustment wheels for the coarse and fine adjustment knob must never be rotated at the same time in opposite directions.

### 10.3 Adjusting the interpupillary distance

#### (for binocular and trinocular devices)

With binocular viewing, the interpupillary distance must be adjusted accurately for each user, in order to achieve a clear image of the object. While you are looking through the eyepieces, use your hands to hold the righthand and lefthand tube housing firmly. By pulling them apart or pushing them together, you can either increase or reduce the interpupillary distance (see illustration). As soon as the field of views of the lefthand and righthand eyepieces completely overlap each other, i.e. they combine to form a circular image, then the interpupillary distance is set correctly.

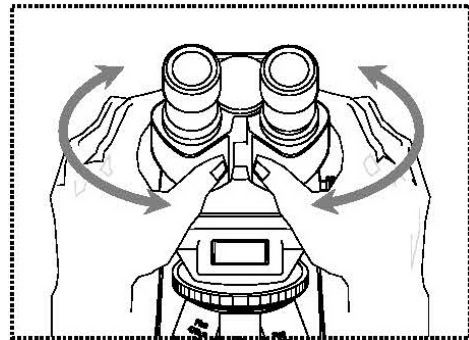

### 10.4 Dioptre adjustment

#### (for binocular and trinocular devices)

The eye strengths of each eye of the microscope user can often be slightly different, which in daily life has no consequences. But when using a microscope this can cause problems in achieving precise focussing.

You can use a mechanism on both tube connectors (dioptre adjustment rings) to compensate for this as follows.

Put the right dioptre adjustment ring to position 0.

1. Look through the right eyepiece with the right eye and bring the object into focus by using the coarse and fine adjustment knob.
2. Then look through the left eyepiece with the left eye and use the lefthand dioptre adjustment ring to focus the image. To do this, you just need to turn the ring in both directions (see illustration), to find out where the image is at its most focussed.

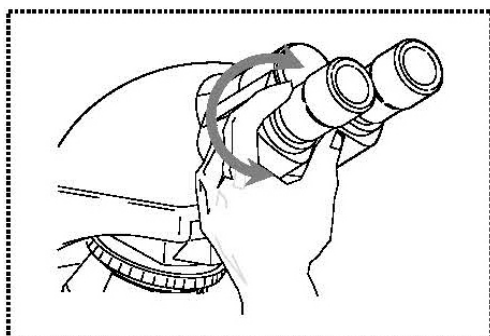

## 10.5 Adjusting the magnification

After pre-focusing has been carried out using the objective with the lowest magnification (see 10.2) you can then adjust the overall magnification using the nosepiece, as necessary. By turning the nosepiece you can bring any one of the four other objectives into the beam path.

When adjusting the nosepiece, you must take the following points into account:

- The required objective must be properly locked in place at all times.
- The nosepiece should not be rotated by holding individual objectives, you should use the silver ring above the objectives (see illustration).
- When rotating the nosepiece you must always make sure that the objective which is about to be positioned in the beam path does not touch the object holder. This can lead to significant damage to the objective lens. We recommend that you always check from the side to make sure that there is sufficient leeway. If this should not be the case, the specimen stage must be lowered accordingly.

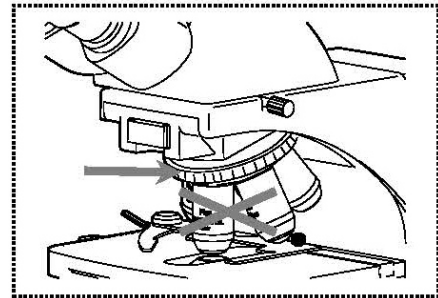

If you have focussed the object to be observed for a specific magnification, then if you select the objective with the next greatest magnification, then the object will be slightly out of focus. Use the fine adjustment knob to make a slight adjustment and restore the focus

## 10.6 Adjusting the Koehler illumination

To make sure that perfect image results are achieved during microscopic observation, it is important that the direction of light of the microscope is optimised. If, as with the devices in the KERN OBN-14 series, the lighting can be set in accordance with Koehler, the result is homogenous illumination of the slide and avoidance of disruptive stray light.

The necessary control elements for this are

- Height-adjustable and centre-adjustable condenser with aperture diaphragm
- Field diaphragm

When adjusting the Koehler lighting for the first time, you must first select the lowest possible objective magnification, so that you can carry out the following steps.

1. Use the condenser focus wheel to position the condenser directly below the specimen stage. Switch on the lighting and use the coarse and fine adjustment knob to bring the slide with the cover glass positioned facing upwards into focus.

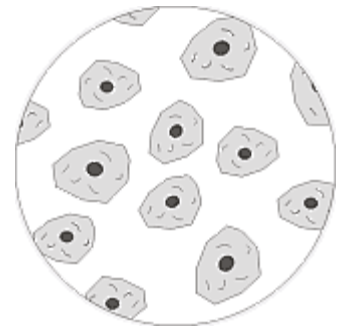

2. Close the field diaphragm completely using its adjusting ring. When you look in the microscope a blurred image appears in the aperture. If the microscopic image is completely dark, the image for the field diaphragm is outside the field of view and must be brought into the field of view using the centring screws on the condenser.



3. Adjust the height of the condenser until the image from the field diaphragm appears clearly in the field of view. For some microscopes there is a risk that you will lift the condenser up so high that it collides with the object holder. Therefore care is needed when doing this.



4. Use the centring screws of the condenser holder to bring the image from the field diaphragm into the centre of the field of view.



5. Open the field diaphragm until it just disappears out of the field of view. If necessary, simply re-centre using the centring screws on the condenser holder.

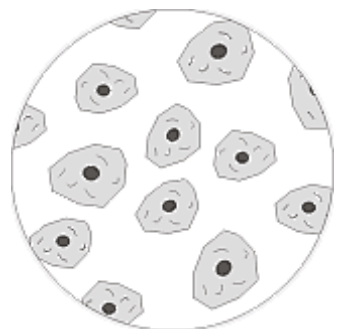

6. Use the aperture diaphragm of the condenser to find the very best compromise between contrast and resolution for the microscopic image. The scale divisions on the condenser can be used as a guideline. Select in accordance with the objective being used. The aperture diaphragm of the condenser can be used.

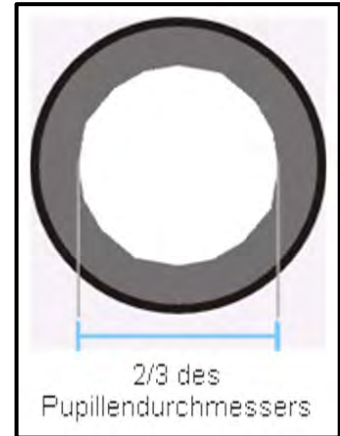

The view in the tube without the eyepiece should look something like the illustration on the right. The diameter of the aperture diaphragm which is then visible should make up approximately  $2/3$  of the pupil diameter.

If the eyepiece should be removed, for checking, then please make sure that no dirt or dust falls into the tube

7. It is possible to alter the brightness of the bulb using the **dimmer**. The brightness is always controlled by the bulb brightness and not by the aperture diaphragm.
8. Possibly there is the need of re-adjusting the focus and x-y axis.
9. Observe the object.

If another magnification is selected afterwards, then the Koehler illumination does not have to be reset from scratch, only the aperture diaphragm and field diaphragm need to be adjusted as required. As a result you can always check whether the condenser needs to be re-centred

## 10.7 Using the eyecups

The eye cups supplied with the microscope can basically be used at all times, as they screen out intrusive light, which is reflected from light sources from the environment onto the eyepiece and the result is a better image quality.

But primarily, if eyepieces with a high eye point (particularly suitable for those who wear glasses) are used, then it may also be useful for users who don't wear glasses, to fit the eye cups to the eyepieces.

These special eyepieces are also called High Eye Point eyepieces. They can be identified by the glasses symbol on the side. They are also marked in the item description by an additional "H" (example: HSWF 10x Ø 23 mm).

When fitting the eye cups, make sure that the dioptre setting is not moved. We would therefore advise that you hold the dioptre compensation ring on an eyepiece with one hand while you fit the eye cup with the other.

Before using the microscope, users who wear glasses must remove the eye cups, which you may find on High Eye Point eyepieces.

As the eye cups are made of rubber, you must be aware that when you are using them, they can become slightly dirty through grease residues. In order to maintain hygiene, we would therefore recommend that you clean the eye cups regularly (e.g. with a damp cloth).



Eyecups



High Eye Point eyepiece  
(recognizable by the glasses symbol)

## 10.8 Use of oil immersion lenses

The 100x objectives of the OBL-14 and OBL-15 series are objectives which can be used with oil immersion (they are always marked with the word "OIL"). Using these generates a particularly high resolution for microscopic images.

To use oil immersion correctly, please follow these steps.

1. Place a drop of oil on the cover slip (with a standard thickness of 0.17 mm) of the preparation.
2. Lower the stage and bring the 100x objective into the beam path.
3. Very slowly move the specimen stage or the specimen towards the objective until light contact is made.
4. Observe the object.

The object slide and objective must not be pressed against each other. The oil constitutes the contact layer.

If the contact is made too jerky, there is a chance that existing air bubbles in the oil cannot escape. This would have a negative impact on image clarity.

After use or before changing the slide, any components which have been in contact with the oil must be cleaned thoroughly. See chapter Maintenance and cleaning..

## 10.9 Phase contrast unit

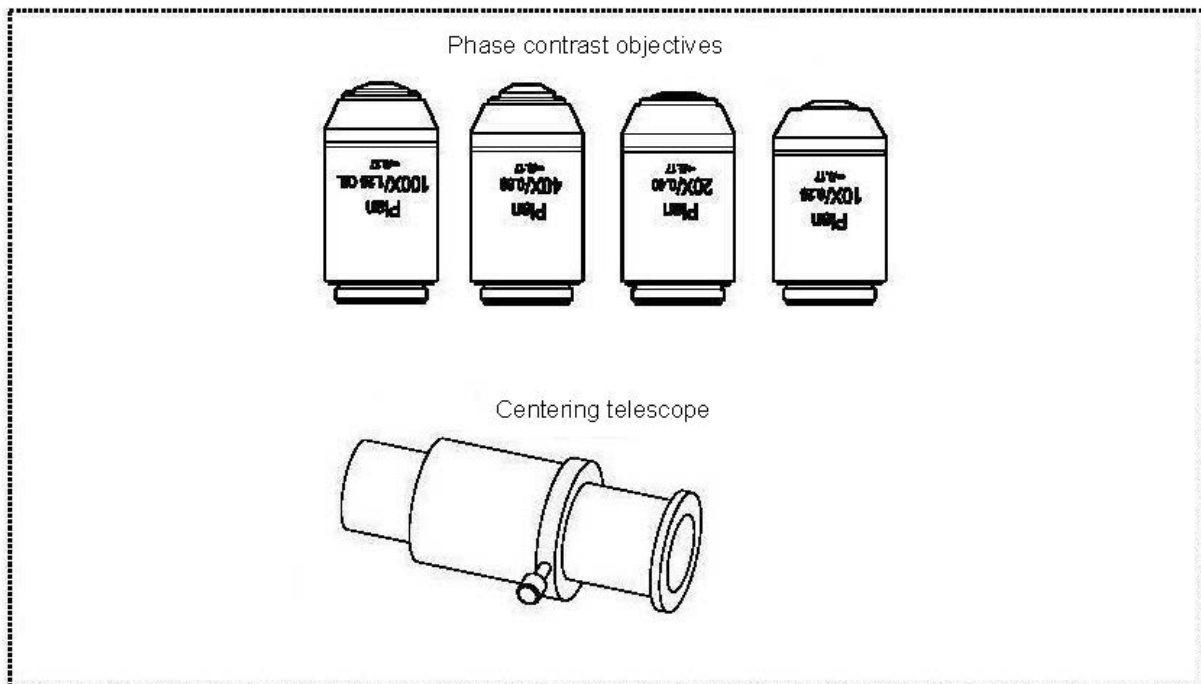

### Simple phase contrast unit

This consists of a simple PH condenser, a PH objective with a specific magnification (10x, 20x, 40x or 100x), a PH slider, which is adapted to the lens being used, a centering telescope and a green filter.

The standard outfit of the models of the series OBL-14 and OBL-15 always includes a 10x and 40x phase contrast unit.

To use this, you need to position the desired PH objective in the beam path and furthermore to place the corresponding PH slide into the insertion point of the PH condenser.

With the surface marked with the magnification information facing up, the PH slider is pushed into the insertion point on the PH condenser until stop. At this position the phase ring of the PH slider is in the beam path and the phase-contrast application can begin. In order to return to the bright field application, you must pull the PH slider out of the condenser, so that the beam can pass the condenser without being affected by the PH slider.

The PH objective has a PH ring in its lens system, just like the PH slider. Due to their size on one hand and their positioning on the other, these two rings must be aligned to one another in the beam path. The position of the ring in the objective cannot be altered, that of the ring in the slider however can be. Before starting the phase-contrast application you have to check if this alignment is given. For this you must install the centring telescope to the tube connector instead of a standard eye piece and look through it (*The appearing image can be focussed by firstly loosening the locking screw on the centring telescope, pull out the front part of the centring telescope to the correct position and finally retightening the locking screw*).

When installing the centring telescope instead of one of the eyepieces there is appearing an image of a white (slide) and a black (objective) ring in the field of view (*see illustration*). The black one is located centrally and the white one possibly shifted to the side. In case of a shift, the position of the white ring has to be adjusted in order to effect an exact overlapping of both rings by means of the two adjusting screws of the condenser.

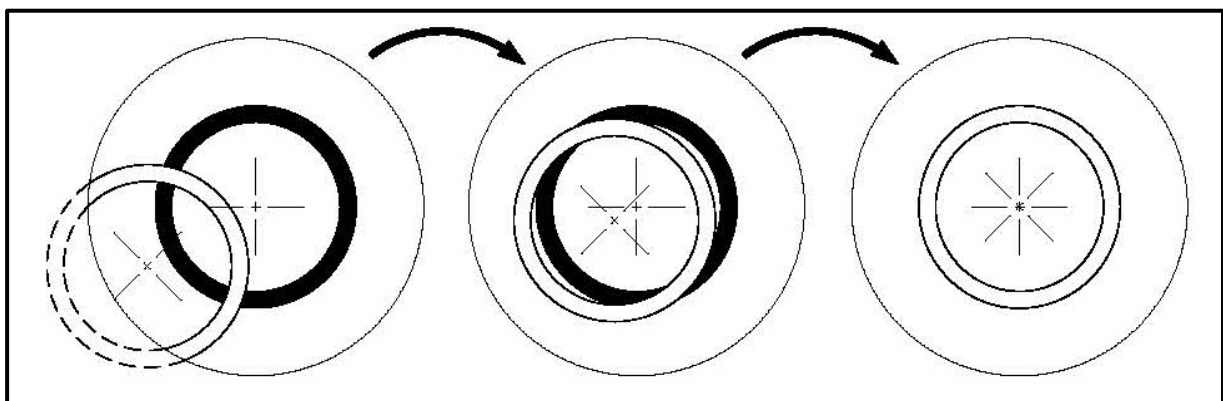

Depending on the preferences of the user, using a green filter can produce a more effective and pleasant image. To achieve this, the green filter must be placed in the ring bracket of the field lens.

## 11 Lamp replacement ( LED)

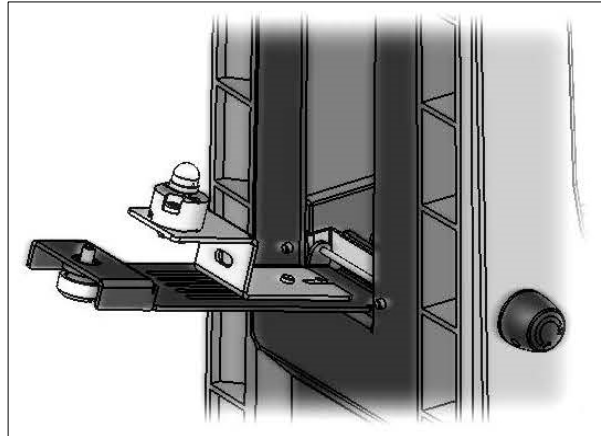
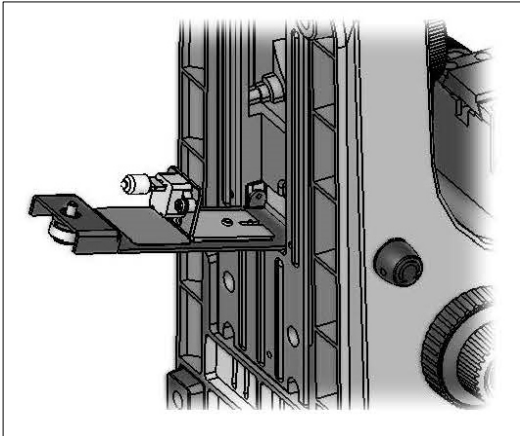

Before changing the bulb the device must be switched off and unplugged.

To change the bulb, tip the device carefully to the back or side. When doing this, please make sure that all microscope components are firmly fixed. The bulb holder is on the underside of the device. It can be opened by undoing the screws on the holder (*see right illustration*). The defective LED module can be removed by loosening the two screws fixing the module and unraveling the connection point of its cable. Now the new module has to be mounted in the same way as the original one. After the bulb holder has been replaced in the underside of the device and the screws replaced, the bulb replacement procedure is complete.

## **12 Use of optional accessories r**

### **12.1 Camera connection (OBL 156)**

Due to the trinocular tube, which is a standard fitting for the model OBL 156, it is possible to connect microscope cameras to the device, in order to digitally record images or sequences of images of an object being observed.

After the plastic cover has been removed from the camera adapter connector on the top of the microscope head, then a suitable adapter must be fitted.

In general there are two C-mount adapters available for this (1x 0,5x and 0.47x magnification) After fitting one of these adapters it can be fixed with the fixing screw. A camera which has a C-mount thread is then screwed on top of the adapter.

We recommend that you first adjust the field of view using the eyepieces on the device for the existing requirements, and then carry out the observation using the microscope camera (i.e. using the PC screen which is connected).

The tube has a light distribution that guarantees the providing of light for the eyepieces and the camera connection at the same time. This means that it is possible to simultaneously observe by the eyepieces and PC screen.

For C-mount adapters, which have their own integrated magnification, the image which is shown on the camera connected to the device can often have a different level of focus compared with the image on the eyepiece.

In order to be able to bring both images into focus, the focus can be adjusted by those adapters.

## 13 Troubleshooting

Problem	Possible causes
Lamp does not burn	Mains plug not plugged in correctly
	No power available at the socket
	Lamp defective
	Fuse defective
Lamp burns out immediately	The prescribed lamp or fuse is not used
Field of vision is dark	Aperture diaphragm and/or field diaphragm are not open wide enough
	The beam path selector slider is set to "Camera"
	The condenser is not centered correctly
Brightness cannot be adjusted	The brightness control is set incorrectly
	The condenser was not centered correctly
	The condenser is lowered too far
Field of vision is dark or not correct illuminated	The lens was not swiveled in correctly
	The beam path selector slide is in an intermediate position
	The object turret is not mounted correctly
	The condenser is not fitted correctly
	A lens is used that does not match the illumination range of the condenser
	The condenser was not centered correctly
	The luminous field diaphragm is closed too far
	The lamp is not mounted correctly
The field of vision of one eye does not match that of the other eye	The interpupillary distance is not set correctly
	The diopter setting was not made correctly
	Different eyepieces are used on the right and left
	The eyes are not used to microscopy

<b>Problem</b>	<b>Possible causes</b>
Blurred details Bad picture Poor contrast Vignetted field of view	Aperture diaphragm is not open wide enough
	Condenser is lowered too far
	The objective does not belong to this microscope
	The front lens of the lens is dirty
	An immersion lens is used without immersion oil
	The immersion oil contains air bubbles
	The condenser is not centered
	The recommended immersion oil is not used
Dirt or dust in the field of vision	Dirt / dust on the lens
	Dirt / dust on the front lens of the condenser
	Dirt / dust on the eyepieces
One side of the image is blurred	Dirt / dust on the front lens of the Condensers
	Dirt / dust on the object
	The table was not assembled correctly
	The lens is not correctly swiveled into the beam path
The picture flickers	The nosepiece is not mounted correctly
	The object rests with the top side facing down.
	The nosepiece is not correct mounted
The coarse drive is difficult to turn	The lens is not mounted correctly swiveled into the beam path
	The condenser was not installed correctly centered
The coarse drive is difficult to turn	The adjusting wheel/torque is too Tightened
	The cross table is operated by a Solid body blocked.

The table moves down by itself The fine adjustment is self-adjusting	The adjusting wheel/torque is not tightened enough
Touching the table blurs the image	The table was not assembled correctly

## **14 Service**

If, despite studying these operating instructions, you still have questions about commissioning or operation, or if, contrary to expectations, a problem should occur, please contact your specialist dealer. The device may only be opened by trained service technicians authorized by KERN.

## 15 Power supply

### 15.1 Mains connection



The microscope may only be connected to the mains if the information on the microscope ( sticker ) and the local mains voltage are identical.



**Important:**

- Check the mains cable for damage before commissioning
- Ensure that the power supply unit does not come into contact with liquids
- The mains plug must be accessible at all times.

## 16 Maintenance, servicing and disposal



Disconnect the appliance from the power supply before carrying out any maintenance, cleaning or repair work.

### 16.1 Cleaning

The appliance must always be kept clean and regularly freed from dust.

Before wiping the appliance when it gets wet, make sure that the power is switched off.

Glass components should preferably be wiped lightly with a lint-free cloth if they become dirty.

To wipe oil stains or fingerprints from lens surfaces, the lint-free cloth is moistened with a mixture of ether and alcohol (70/30 ratio) and then cleaned

Ether and alcohol must always be handled with care as they are highly flammable substances. It is therefore essential to keep them away from naked flames and electrical appliances that are switched on and off and only use them in well-ventilated rooms.

However, organic solutions of this type should not be used to clean other components of the appliance. This could cause changes to the paintwork. It is sufficient to use a neutral cleaning agent for this purpose.

Other cleaning agents for the optical components include

- Special cleaner for optical lenses
- Special optical cleaning cloths
- Bellows
- Brush

If handled correctly and checked regularly, the microscope will function smoothly for many years.

### 16.2 Maintenance and repair

Do not make any changes to the device and do not install any spare parts. Contact the manufacturer for repair or device inspection.

## 16.3 Waste disposal



Old appliances and accessories must not be disposed of with household waste.

The operator must dispose of the packaging and the device at the place of use in accordance with the applicable national or regional legislation. The device consists of various components and materials, such as

- Electronic components (printed circuit boards, electrical cables)
- Plastic (housing)
- Metal

Improper disposal of the appliance can have harmful effects on people and the environment.

Proper and environmentally friendly disposal can prevent harmful effects and recover raw materials.

## 17 Further information

The illustrations may differ slightly from the product.

The descriptions and illustrations in these operating instructions are subject to change without notice. Further developments to the device may result in such changes.



All language versions include a non-binding translation.  
The original German document is binding.