



Transmitted light phase contrast microscope

OBN-15

OBN 158, OBN 159



PROFESSIONAL MEASURING

english version

Operating instructions Transmitted light phase contrast microscope

Version 1.2
2024-09
en
OBN-15-BA-e-2412.docx

KERN Optics OBN-15

Transmitted light phase contrast microscope

Operating instructions Transmitted light phase contrast microscope

Version 1.2 2024-09 english version

Table of contents:

1	Technical data	3
2	Declaration of conformity	4
3	Device overview	5
3.1	Nomenclature	5
4	Before Use	9
4.1	General information	9
5	Basic information (general)	10
5.1	General information on warnings	10
5.2	Intended use	11
5.3	Improper use	11
5.4	Warranty	11
6	Basic warnings and safety instructions	12
6.1	Observe the notes in the operating instructions	12
6.2	Staff training	12
6.3	Security.....	12
7	Transportation and storage	15
7.1	Note	15
7.2	Transportation	15
7.3	Storage	15
7.4	Packaging/return transportation	15
8	Unpacking and commissioning	16
8.1	Unpacking.....	16
8.2	Initial commissioning	16
9	Assembly	17
9.1	Microscope head	18
9.2	Objectives	18
9.3	Eyepieces	18
9.4	Color filter	18
9.5	PH condenser.....	18
10	Operation	19
10.1	First steps	19
10.2	(Pre-) focusing	20
10.3	Setting g the interpupillary distance	21
10.4	Diopter compensation.....	21
10.5	Adjusting the magnification	22
10.6	Adjusting the Koehler Illumination	23
10.7	Using eye cups	26
10.8	Use of oil immersion lenses	27
10.9	Phase contrast units	28
11	Changing the bulb	30

12	Changing the Fuse (OBN 158)	32
13	Using optional accessories	33
13.1	Camera connection	33
14	Troubleshooting	34
15	Service	37
16	Power supply	38
16.1	Mains connection.....	38
17	Maintenance, servicing and disposal	39
17.1	Cleaning	39
17.2	Maintenance and repair.....	39
17.3	Waste disposal	40
18	Further information	41

1 Technical data

Kern model	OBN 158	OBN 159
Item number/type	OBN 158	TOBN 159-A
Dimensions (WxDxH)	390x200x400 mm	
Tubus Art	Trinocular	
Optical system	Infinity	
Revolving nosepiece screw-in positions	5	
Lens quality	Infinity Plan	
Standard objectives	4x PH 10x PH 20x PH 40x PH 100x	
Eyepiece field width	HWF	
Illuminance Transmitted light	20 W	3 W
Type of lighting Transmitted light	Halogen	LED
Lighting equipment	Transmitted light	
Condenser type	PH universal rotary condenser	
Condenser aperture	1,25	
Input voltage power supply / current [Max]	100 - 240V AC 50/60 Hz	100 - 240V AC 50/60Hz 0.3A
Input voltage device / current [Max]	100 - 240V 50/60 Hz	5V, 1A
Plug-in power supply type	Built-in power supply unit	Plug-in power supply
Fuse	5 A	-
Focusing mechanism	Coaxial coarse and fine drive	
Packaging dimensions	535x370x270 mm	
Net weight	10 kg	
Gross weight	11 kg	

2 Declaration of conformity

The current EC/EU Declaration of Conformity can be found online at:

<https://www.kern-sohn.com/shop/de/DOWNLOADS/>

3 Device overview

3.1 Nomenclature

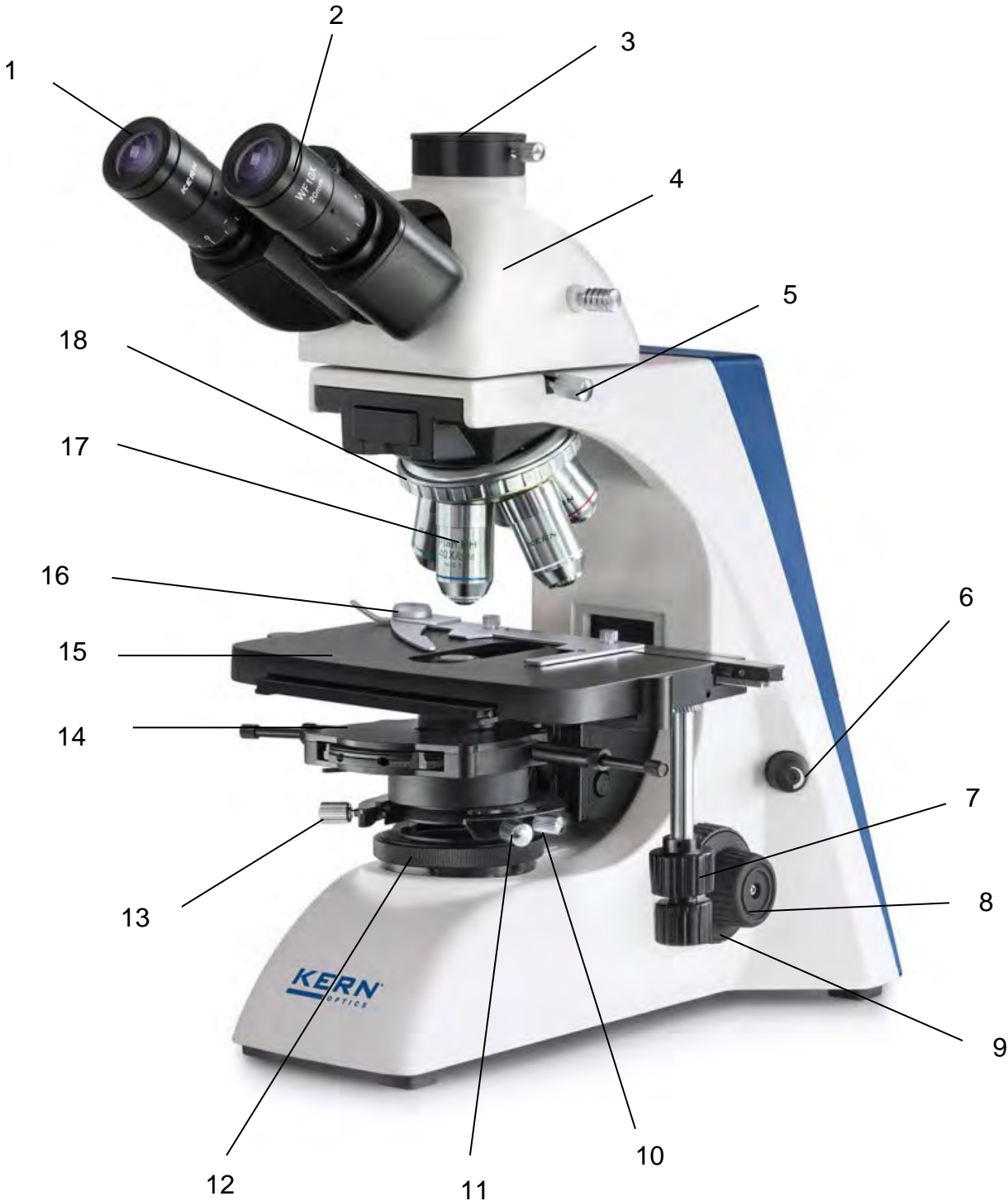

	Description
1	Eyepieces
2	Tube connectors with dioptre adjustment ring
3	Camera adapter connection
4	Microscope head / tube
5	Adjusting screw Microscope head
6	Dimmer+ Main switch
7	Setting wheel X-Y axis Specimen stage
8	Fine drive
9	Coarse drive
10	Adjusting screw Condensor
11	Centering screw Condensor
12	Field lens with field diaphragm
13	Centering screw Condensor
14	PH universal rotary condenser
15	Specimen stage
16	Object holder
17	Objective
18	Nosepiece

Rear view

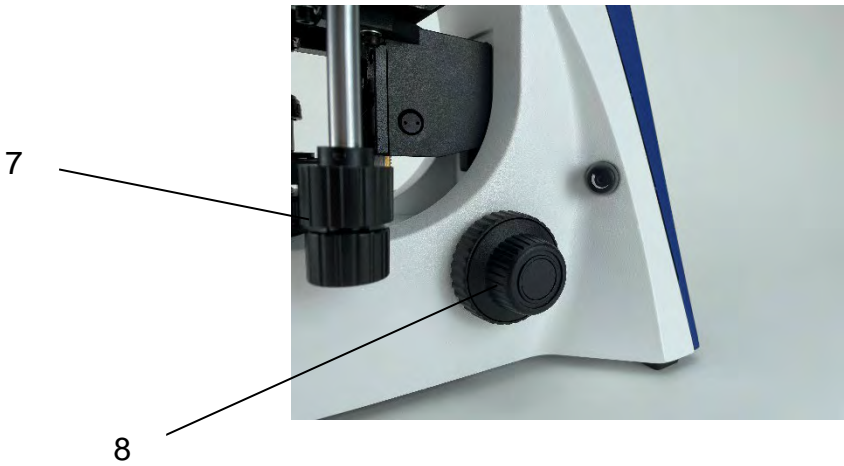
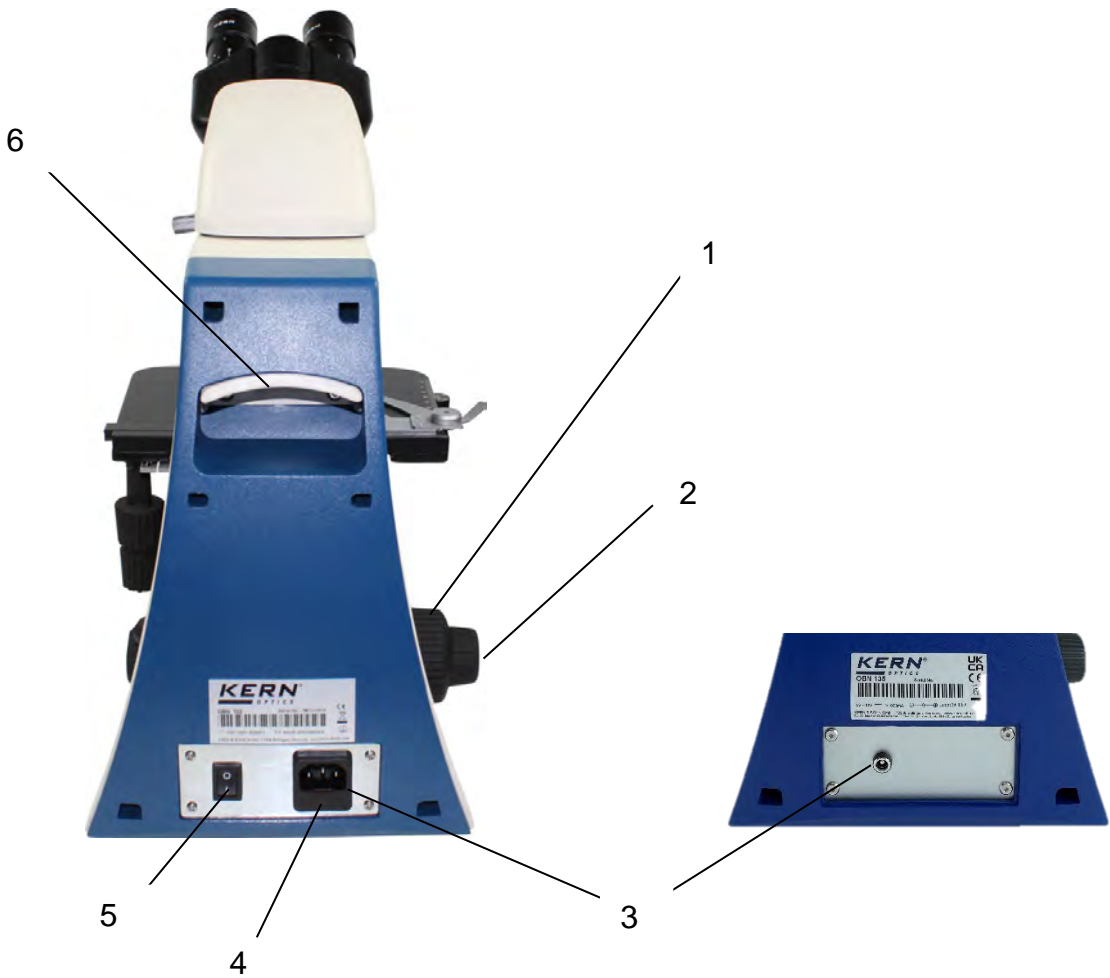

	Description
1	Coarse drive
2	Fine drive
3	Power connection
4	Fuse
5	Main switch
6	Carrying handle
7	Condenser Focus wheel
8	Adjustment ring Torque

4 Before Use

4.1 General information

The packaging must be opened carefully to prevent the accessories inside from falling to the floor and breaking.

In general, a microscope should always be handled with great care, as it is a sensitive precision instrument. Avoiding abrupt movements during operation or transportation is therefore particularly important, especially to avoid endangering the optical components.

You should also avoid dirt or fingerprints on the lens surfaces, as in most cases this impairs the sharpness of the image.

If the performance of the microscope is to be maintained, it must never be disassembled. Parts such as objective lenses and other optical components should therefore be left as they are at the start of operation.





5 Basic information (general)

5.1 General information on warnings

Warnings are used in these operating instructions to warn you of possible personal injury or damage to property in certain situations.

Signal word	Description
DANGER	Failure to observe the instructions will lead directly to serious injury, permanent impairment (e.g. loss of a limb) or death of the user or third parties
WARNING	Failure to observe the instructions may result in serious injury, permanent impairment (e.g. loss of a limb) or death of the user or third parties
CAUTION	Failure to observe the instructions may result in minor injuries or temporary damage to the user or third parties (e.g. minor cuts)
NOTE	Failure to observe the instructions may result in damage to property

Symbols in warning notices :

Icon	Meaning
Warning signs	Warning signs warn you of dangers that may lead to personal injury. The symbol indicates the type of hazard.
	Indicates general hazards or a danger point
	Warning of electrical voltage
	Warning of optical radiation
	Indicates electrostatic sensitive devices

Icon	Meaning
Commandment sign	Mandatory signs prescribe measures that you must take to avoid personal injury or damage to property. The symbol indicates the necessary actions or objects to prevent damage.
	Indicates a prescribed action

5.2 Intended use

The OBN-15 is versatile and is mainly used for the analysis of translucent and thin, low-contrast, challenging specimens (e.g. living mammalian cells, bacteria, tissue)

5.3 Improper use

Do not use the device in potentially explosive atmospheres or for measurements in liquids or on live parts.

Unauthorized structural changes, additions and conversions to the appliance are prohibited.

5.4 Warranty

The guarantee expires in the event of

- Non-compliance with our specifications in the operating instructions
- Use outside the described applications
- Modifying or opening the device
- Mechanical damage and damage caused by media, liquids, natural wear and tear
- Improper set-up or electrical installation
- Improper assembly or electrical installation

6 Basic warnings and safety instructions

6.1 Observe the notes in the operating instructions



Read the operating instructions carefully before commissioning/using the device, even if you already have experience with KERN devices. Always keep the instructions in the immediate vicinity of the appliance.

6.2 Staff training

The appliance may only be used by persons who have read and understood the operating instructions, in particular the chapter on safety.

6.3 Security

⚠ WARNING	
	<p>Read all safety information and instructions. Failure to observe the safety information and instructions may result in electric shock, fire and/or serious injury.</p> <p>Keep all safety information and instructions for future reference.</p> <ul style="list-style-type: none">● The design of the device must not be modified. This can lead to incorrect measurement results, safety defects and destruction of the device● Do not operate the appliance in potentially explosive rooms or areas and do not install it there.● Do not operate the device in an aggressive atmosphere.● Do not immerse the appliance in water. Ensure that no liquids penetrate the inside of the device. <p>The device may only be used in a dry environment and under no circumstances in rain or relative humidity above the operating conditions.</p> <ul style="list-style-type: none">● Protect the device from permanent direct sunlight.● Do not expose the device to strong vibrations.● Do not remove any safety signs, stickers or labels from the device. Keep all safety signs, stickers and labels in a legible condition● Do not open the device● The lamp generates a lot of heat during operation. Avoid touching the lamp housing during operation and for some time afterwards.● Do not operate the device in an aggressive atmosphere

⚠ WARNING



Risk of injury due to electric shock!

- Risk of short circuit due to penetration of liquids into the housing!
- Do not immerse the appliance or accessories in water. Make sure that no water or other liquids get into the housing.
- Work on electrical components may only be carried out by an authorized specialist company!
- Take care not to twist or kink the mains cable.
- Only use the original adapter supplied

⚠ WARNING



Choking hazard!

Do not leave the packaging material lying around carelessly. It could become a dangerous toy for children.

- The appliance is not a toy and does not belong in the hands of children.
- This appliance can be dangerous if it is used improperly or not as intended by untrained persons! Observe the personnel qualifications!

⚠ WARNING



Electrostatic sensitive device!

- The device can be destroyed by electrostatic discharges. Connectors for HF signals are particularly at risk.
- Please observe the handling instructions for electrostatically sensitive components.

⚠ WARNING



There is a risk from optical radiation!

Gas discharge lamps, LED lights and other white light sources generate intense optical radiation, including UV (ultraviolet), visible light (VIS) and IR (infrared). This radiation can cause both skin and eye damage. The extent of the damage is determined by the wavelength, the duration of exposure and the operating mode (continuous or pulsed).

- Do not expose eyes and skin to radiation.
- Do not insert any reflective objects into the beam entrance.
- If necessary, use suitable protective equipment/protective clothing.
- Never remove the cover or cladding during operation.
- Never look into the eyepieces when the beam path is open (using the control lever for illumination) and an empty filter position is selected on the FL module. There is an acute risk of blindness here.

CAUTION

Keep a sufficient distance from heat sources.

Do not use the device in environments with high humidity or water mist

NOTE

- To avoid damaging the device, do not expose it to extreme temperatures, extreme humidity or moisture.
- Do not use harsh cleaners, abrasive cleaners or solvents to clean the appliance.

7 Transportation and storage

7.1 Note

If you store or transport the device improperly, the device may be damaged. Observe the information on transporting and storing the appliance.

7.2 Transportation

We recommend using the original packaging for shipping, transportation or storage of the microscope components. To prevent damage from shocks, all moving parts that can be assembled and disassembled must be packed separately.

7.3 Storage

Avoid exposing the device to direct sunlight, high or low temperatures, shocks, dust and high humidity.

The suitable temperature range is 0 - 40 °C and a relative humidity of 85% should not be exceeded.

The appliance should always be placed on a firm, smooth and horizontal surface.

When the microscope is not in use, it is best to cover it with the dust cover supplied. Dust or dirt inside the optics of a microscope can in many cases lead to irreversible malfunctions or damage.

Accessories consisting of optical elements, such as additional lenses, are preferably stored in a drying box with desiccant.

7.4 Packaging/return transportation

Returns are only possible within the limits of the general terms and conditions. Keep all parts of the original packaging for any necessary return transportation.

- Only the original packaging is to be used for return transportation.
- Disconnect all connected cables and loose/movable parts before shipping.
- Refit any transportation locks provided.
- Secure all parts against slipping and damage.

8 Unpacking and commissioning

8.1 Unpacking



In the event of a return, please observe the instructions in the chapter "Packaging/return transportation"

On receipt of the device, you should first check that no damage has occurred during transportation, that the outer packaging, the housing, other parts or even the device itself have not been damaged. If any damage is evident, please notify KERN GmbH immediately.

8.2 Initial commissioning

To ensure the function of the microscope, it must be cleaned as described in chapter 9.

9 Assembly

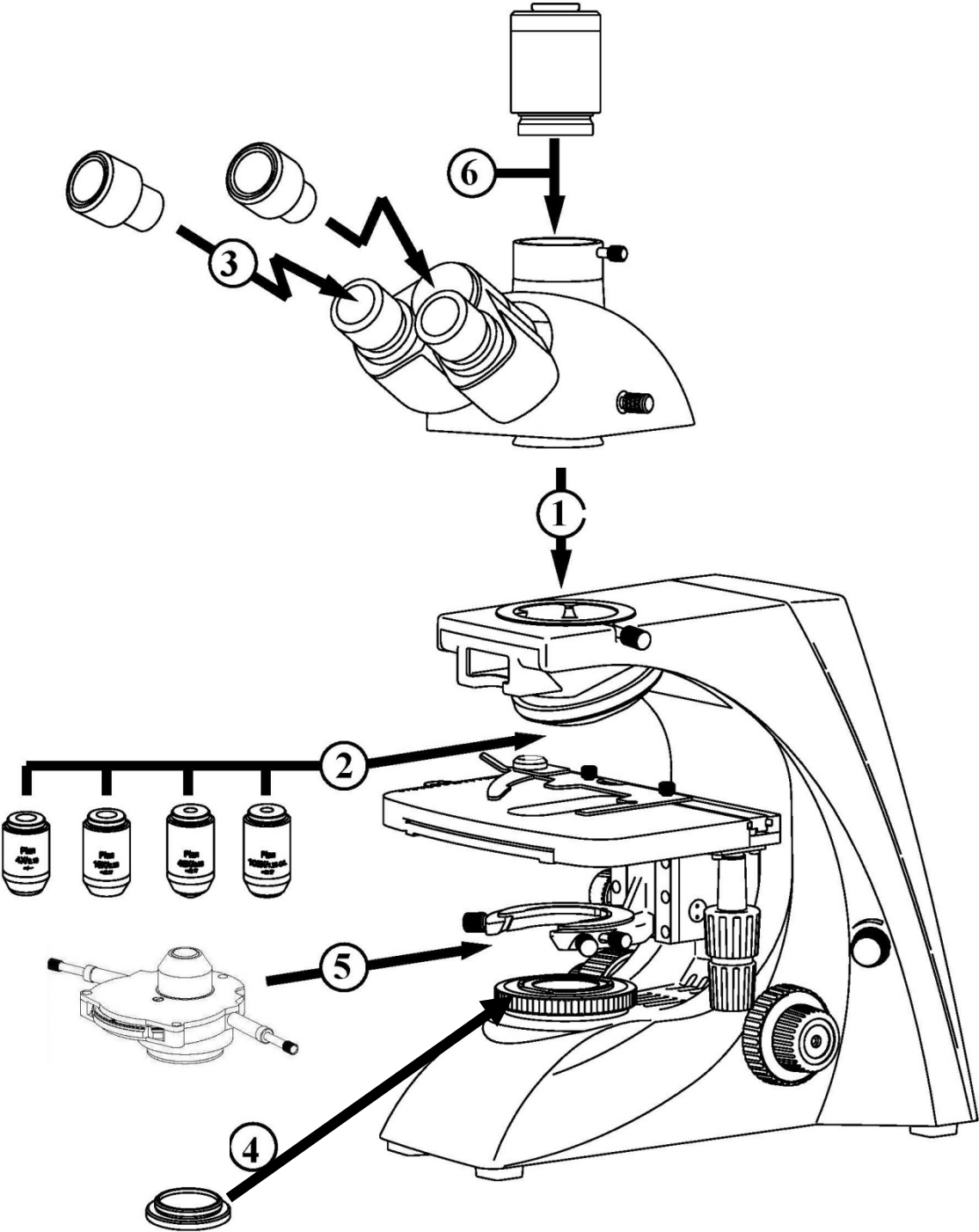

9.1 Microscope head

First, the fastening screw at the tube connection point must be loosened and the black protective cover removed.

The round dovetail holder on the head can now be inserted into the round dovetail holder on the housing and secured with the fixing screw. Care should always be taken to ensure that the lenses are not touched with bare fingers and that no dust enters the openings.

9.2 Objectives

Depending on the model, all three or four lenses are already screwed onto the nosepiece. After removing the protective film, the objectives are ready for use. They are arranged in such a way that the objective with the next highest magnification appears when the nosepiece is turned clockwise. If the objectives are unscrewed, care must be taken to ensure that the lenses are not touched with bare fingers and that no dust enters the openings. For objectives marked "OIL", an immersion oil with the lowest possible inherent fluorescence effect must be used.

9.3 Eyepieces

Eyepieces with the same magnification for both eyes must always be used. These are simply placed on the tube sockets once the plastic protective caps have been removed. Care should always be taken to ensure that the lenses are not touched with bare fingers and that no dust enters the openings.

9.4 Color filter

A blue / green color filter can simply be placed in the ring holder of the field lens.

9.5 PH condenser

It is best to move the stage to the top position using the coarse drive. The focus wheel of the condenser must now be used to move the condenser carrier to a middle position. The condenser can then be inserted into the condenser carrier at the appropriate position and fixed in place with the locking screw. The turntable should point centrally to the front.

The two centering screwdrivers can be attached to the appropriate positions on the sides of the condenser using the screw connection of their spring holder. You should always avoid touching the optical lenses with your bare fingers.

For more information on using the PH condenser, see 5.9 Phase contrast unit.

For point 6 (Camera connection) chapter 13 Use of optional accessories.

10 Operation

10.1 First steps

When the microscope is ready for use after assembly, it must first be connected to the mains via the mains cable. Only insert the mains plug into a suitable socket. Ensure that the mains cable is laid correctly.

The following sections describe all the important functions that are useful for operating the device.

The first thing to do is to connect the power supply using the mains plug. The light intensity control (dimmer) should first be set to a low level so that the eyes are not immediately exposed to too much light when looking into the eyepieces for the first time. The lighting can now be switched on using the main switch.

The next step is to place a slide with a sample on the stage. The cover glass must be facing upwards for this. The object holder can be used to fix the slide on the stage (see illustration on the left). To move the sample into the beam path, the adjustment wheels on the right-hand side of the mechanical stage must be operated accordingly (see illustration on the right).

A total of two slides can be placed at the same time.

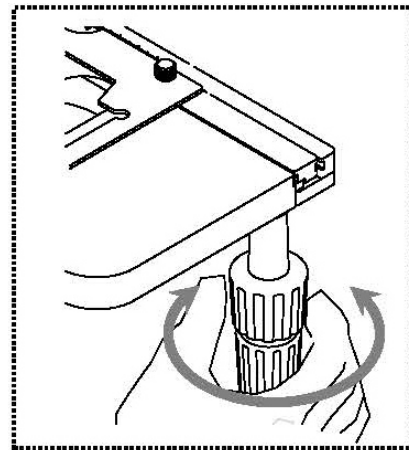
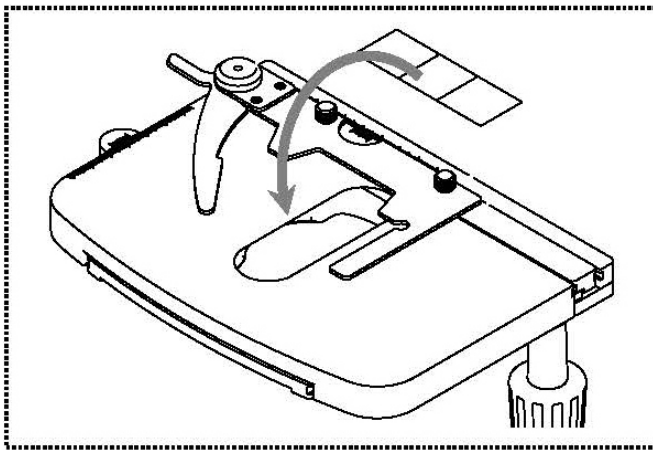

10.2 (Pre-) focusing

When you are observing an object, you must have the correct distance to the objective to achieve a sharp image. In order to find this distance at the beginning (without other default settings of the microscope) place the objective with the lowest magnification in the beam path, look through the right eyepiece with the right eye and turn it slowly using the coarse adjustment knob (see illustration).

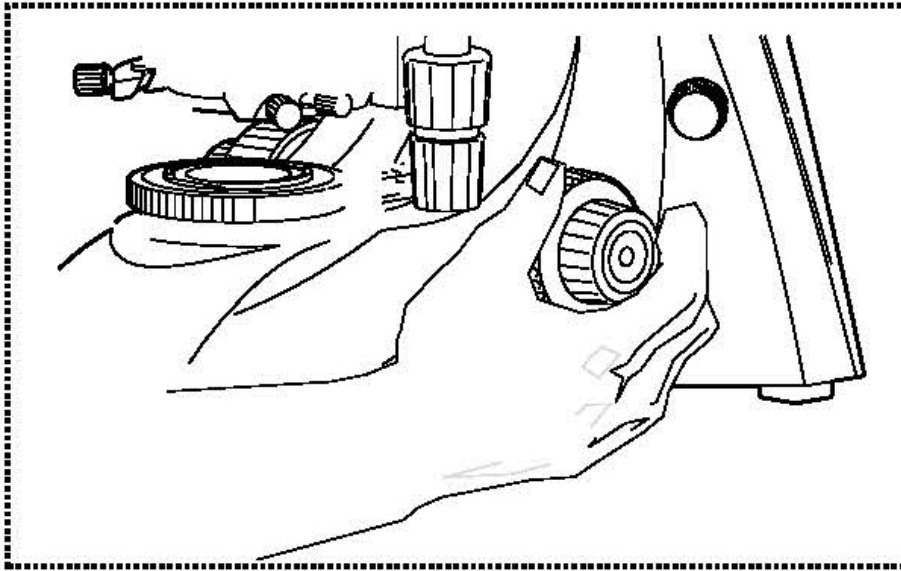

The simplest way of doing this would be to first raise the specimen stage (using the coarse adjustment knob) until it is just under the objective and then lower it slowly. As soon as an image is recognisable (no matter how sharp), then you should only adjust the focus using the fine adjustment knob.

Adjusting the torque of the coarse and fine adjustment knob

Next to the left adjustment wheel for the coarse and fine adjustment knob there is a ring which you can use to alter the torque of these wheels. Turning it in a clockwise direction reduces the torque and turning it in an anti-clockwise direction increases it. On one hand, this function can help to make it easier to adjust the focus and on the other hand it can prevent the specimen stage from slipping down unintentionally.

Important:

In order to avoid damaging to the focussing system, the left and right adjustment wheels for the coarse and fine adjustment knob must never be rotated at the same time in opposite directions.

10.3 Setting the interpupillary distance

(for binocular and trinocular devices)

With binocular viewing, the interpupillary distance must be adjusted accurately for each user, in order to achieve a clear image of the object.

While you are looking through the eyepieces, use your hands to hold the righthand and lefthand tube housing firmly. By pulling them apart or pushing them together, you can either increase or reduce the interpupillary distance (*see illustration*).

As soon as the field of views of the lefthand and righthand eyepieces completely overlap each other, i.e. they combine to form a circular image, then the interpupillary distance is set correctly.

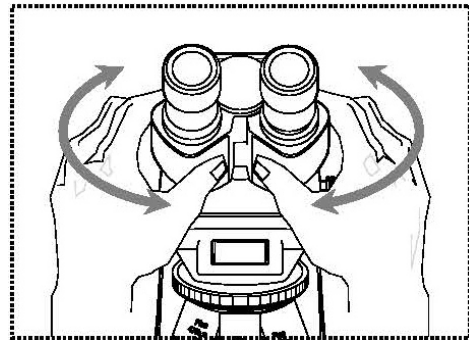

10.4 Diopter compensation

(for binocular and trinocular devices)

The eye strengths of each eye of the microscope user can often be slightly different, which in daily life has no consequences. But when using a microscope this can cause problems in achieving precise focussing.

You can use a mechanism on both tube connectors (dioptre adjustment rings) to compensate for this as follows.

1. Put the right dioptre adjustment ring to position 0.
2. Look through the right eyepiece with the right eye and bring the object into focus by using the coarse and fine adjustment knob.
3. Then look through the left eyepiece with the left eye and use the lefthand dioptre adjustment ring to focus the image.

To do this, you just need to turn the ring in both directions (*see illustration*), to find out where the image is at its most focussed.

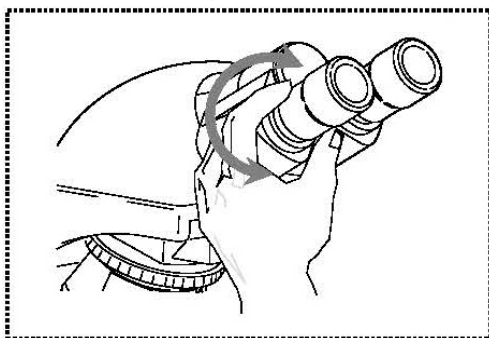

10.5 Adjusting the magnification

After pre-focusing has been carried out using the objective with the lowest magnification (see section 10.2), you can then adjust the overall magnification using the nosepiece, as necessary. By turning the nosepiece you can bring any one of the four other objectives into the beam path.

When adjusting the nosepiece, you must take the following points into account:

- The required objective must be properly locked in place at all times.
- The nosepiece should not be rotated by holding individual objectives, you should use the silver ring above the objectives (see illustration).

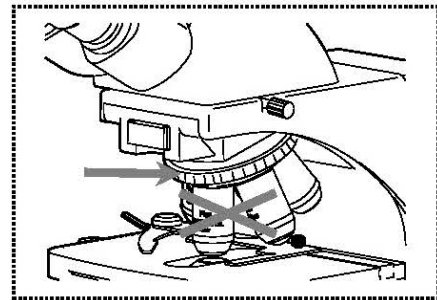

- When rotating the nosepiece you must always make sure that the objective which is about to be positioned in the beam path does not touch the object holder. This can lead to significant damage to the objective lens.

We recommend that you always check from the side to make sure that there is sufficient leeway. If this should not be the case, the specimen stage must be lowered accordingly.

If you have focussed the object to be observed for a specific magnification, then if you select the objective with the next greatest magnification, then the object will be slightly out of focus. Use the fine adjustment knob to make a slight adjustment and restore the focus.

10.6 Adjusting the Koehler Illumination

To make sure that perfect image results are achieved during microscopic observation, it is important that the direction of light of the microscope is optimised. If, as with the devices in the KERN OBN-15 series, the lighting can be set in accordance with Koehler, the result is homogenous illumination of the slide and avoidance of disruptive stray light.

The necessary control elements for this are:

- Height-adjustable and centre-adjustable condenser with aperture diaphragm
- Field diaphragm

When adjusting the Koehler lighting for the first time, you must first select the lowest possible objective magnification, so that you can carry out the following steps.

1. Use the condenser focus wheel to position the condenser directly below the specimen stage. Switch on the lighting and use the coarse and fine adjustment knob to bring the slide with the cover glass positioned facing upwards into focus.

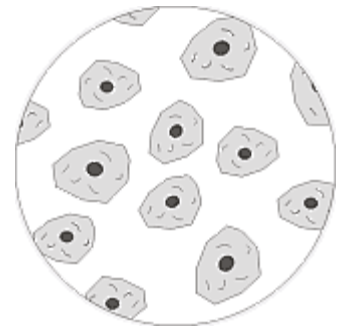

2. Close the field diaphragm completely using its adjusting ring. When you look in the microscope a blurred image appears in the aperture. If the microscopic image is completely dark, the image for the field diaphragm is outside the field of view and must be brought into the field of view using the centring screws on the condenser.



- Adjust the height of the condenser until the image of the field diaphragm appears sharp in the field of view. With some microscopes, there is a risk of raising the condenser too high and causing a collision with the microscope slide. A little caution is therefore required here.



- Use the centering screws of the condenser carrier to bring the image of the field diaphragm into the center of the field of view.



- Open the field diaphragm until it just disappears out of the field of view. If necessary, simply re-centre using the centring screws on the condenser holder.

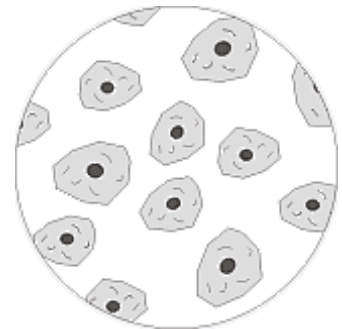

- Use the aperture diaphragm of the condenser to find the very best compromise between contrast and resolution for the microscopic image. The scale divisions on the condenser can be used as a guideline. Select in accordance with the objective being used.

The view in the tube without the eyepiece should look something like the illustration on the right.

The diameter of the aperture diaphragm which is then visible should make up approximately $\frac{2}{3}$ of the pupil diameter.

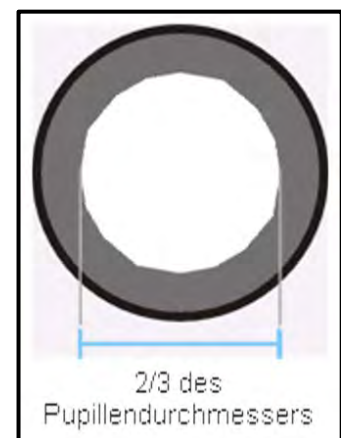

If the eyepiece should be removed, for checking, then please make sure that no dirt or dust falls into the tube.

7. It is possible to alter the brightness of the bulb using the **dimmer**. The brightness is always controlled by the bulb brightness and not by the aperture diaphragm.
8. Possibly there is the need of re-adjusting the focus and x-y axis.
9. Observe the object.

If another magnification is selected afterwards, then the Koehler illumination does not have to be reset from scratch, only the aperture diaphragm and field diaphragm need to be adjusted as required.

As a result you can always check whether the condenser needs to be re-centred.

10.7 Using eye cups

The eye cups supplied with the microscope can basically be used at all times, as they screen out intrusive light, which is reflected from light sources from the environment onto the eyepiece, and the result is better image quality.

But primarily, if eyepieces with a high eye point (particularly suitable for those who wear glasses) are used, then it may also be useful for users who don't wear glasses, to fit the eye cups to the eyepieces.

These special eyepieces are also called High Eye Point eyepieces. They can be identified by the glasses symbol on the side. They are also marked in the item description by an additional "H" (example: HSWF 10x Ø 23 mm).

When fitting the eye cups, make sure that the dioptre setting is not moved. We would therefore advise that you hold the dioptre compensation ring on an eyepiece with one hand while you fit the eye cup with the other.

Before using the microscope, users who wear glasses must remove the eye cups, which you may find on High Eye Point eyepieces.

As the eye cups are made of rubber, you must be aware that when you are using them, they can become slightly dirty through grease residues. In order to maintain hygiene, we would therefore recommend that you clean the eye cups regularly (e.g. with a damp cloth).



Eyecups



High Eye Point eyepiece
(recognizable by the glasses symbol)

10.8 Use of oil immersion lenses

The 100x objectives of the OBN-15 series are objectives which can be used with oil immersion (they are always marked with the word "OIL"). Using these generates a particularly high resolution for microscopic images.

To use oil immersion correctly, please follow these steps.

1. Put a drop of oil on the cover glass (with standard thickness of 0.17 mm) of the object slide.
2. Lower the specimen stage and position the 100x objective in the beam path.
3. Bring the specimen stage or object slide to the objective very slowly until there is slight contact.
4. Observe the object.

The object slide and objective must not be pressed against each other. The oil constitutes the contact layer.

If the contact is made too jerky, there is a chance that existing air bubbles in the oil cannot escape. This would have a negative impact on image clarity.

After use or before changing the slide, any components which have been in contact with the oil must be cleaned thoroughly. See *chapter Maintenance and cleaning*.

10.9 Phase contrast units

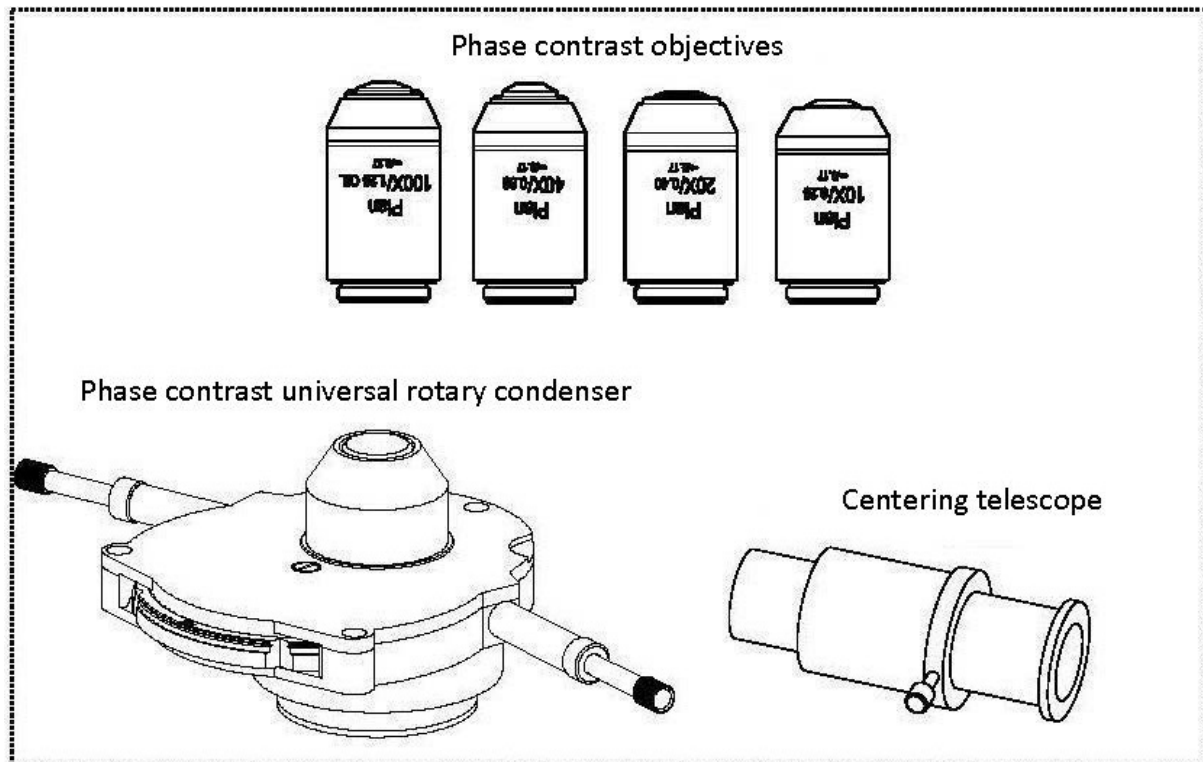

Comprehensive phase contrast unit

This consists of a PH universal rotary condenser, four PH objectives (10x, 20x, 40x and 100x), a centring telescope, two centring turnscrews and a green filter. This comprehensive PH unit is always included in the standard outfit of the models of the series OBN-15.

To use this, you need to position one of the required PH objectives in the beam path and to check if the centring turnscrews are attached to the condenser.

The condenser has a hub with five positioning options. Four of these are fitted with a phase ring, which matches only one specific objective magnification. When doing this you must note the marking on the rotary knob at the relevant position. The empty position is intended for bright field applications.

A PH objective has a PH ring in its lens system, just like the individual positions of the PH universal rotary condenser. Due to their size on one hand and their positioning on the other, the two related rings must be aligned to one another in the beam path. The position of the ring in the objectives cannot be altered, that of the rings in the condenser disc however can be.

The adjustment for this is carried out as follows.

- a. First adjust the microscope using bright field mode.
- b. Move the hub to the required PH position (e.g. "10x").
- c. Open the aperture diaphragm on the condenser to its maximum (slider to the left).
- d. Bring the relevant PH objective (e.g. 10x) into the beam path.
- e. Place the centring telescope onto one of the two tube connectors, in place of a standard eyepiece.
- f. Undo the fixing screw of the centring telescope and pull out (move) the front part of the telescope, so that you can focus both phase rings in the field of view. You can also use the focus wheel of the condenser holder when doing this. Then retighten the screws.

In the field of view you will now see the image of a white (condenser) and a black (objective) ring. The black one is central and the white one possible is pushed to one side (*see left illustration*).

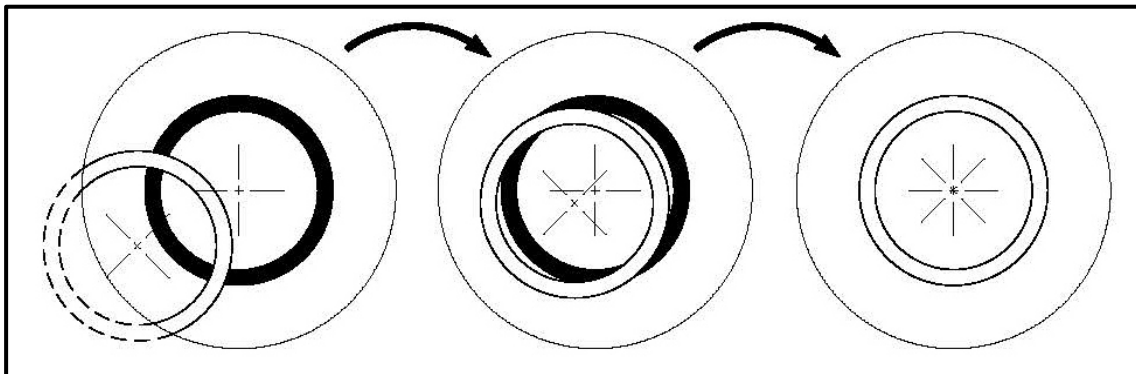

- g. Now press the turnscrews fitted on the side of the condenser towards the centre until they grip the screws. Then by turning the screws and at the same time watching the rings through the centring telescope, move the white ring to the centre (*see central illustration*).
- h. As soon as both the rings overlap each other (*see right illustration*) the adjustment is successfully completed and can also be carried out for the pairs of rings of the other magnifications.
- i. After the adjustment, the centring telescope must be replaced by the standard eyepiece, so that you are able to observe the object on the angle table in phase contrast mode.

Depending on the preferences of the user, using a green filter can produce a more effective and pleasant image. To achieve this, the green filter must be screwed onto the underside of the PH condenser.

11 Changing the bulb

Halogen

You must not attempt to change the bulb immediately after the microscope has been used, as the bulb will still be hot and so there is a risk that the user could be burnt. Before changing the bulb the device must be switched off and unplugged.

To change the bulb, tip the device carefully to the back or side. When doing this, please make sure that all microscope components are firmly fixed. The bulb holder is on the underside of the device. It can be opened by undoing the screws on the holder (see *illustration*). We recommend that here you should also test again, to check that heat is no longer being produced. The defective bulb can be pulled out of the socket and be replaced with a new one. After the bulb holder has been replaced in the underside of the device and the screws replaced, the bulb replacement procedure is complete.

Important:

When fitting the new bulb into the socket, it must only be handled with sterile gloves or using the bulb packaging film. Grease and dust residue can have a negative effect on the light quality and service life.

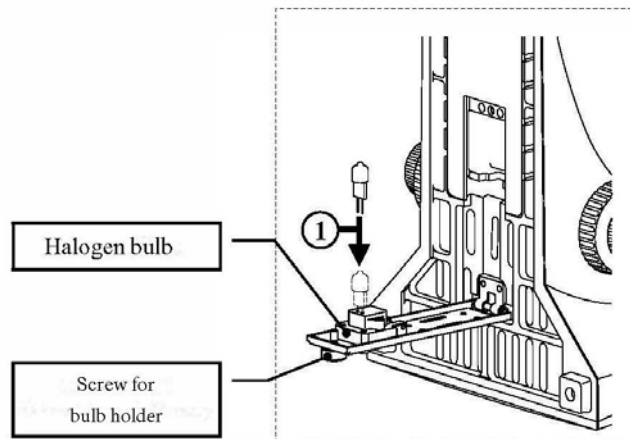

LED (OBN 159)

The OBN 159 is equipped with LEDs.

Due to the long service life of LED lighting, regular lamp replacement will not be necessary with this microscope.

In most cases, problems with the lighting would therefore be caused by defects in the electrical system. In such a case, our Technical Service can help

12 Changing the Fuse (OBN 158)

The fuse housing is located at the rear of the microscope below the mains plug connection. When the device is switched off and the mains plug is removed, the housing can be pulled out. It is advisable to use a screwdriver or similar tool to help with this. The defective fuse can now be removed from its housing and replaced with a new one.

The fuse housing must then be reinserted into the slot below the mains plug connection.

13 Using optional accessories

13.1 Camera connection

Due to the trinocular tube, which is a standard fitting for the whole OBN-15 series, it is possible to connect microscope cameras to the device, in order to digitally record images or sequences of images of an object being observed.

After the plastic cover has been removed from the camera adapter connector on the top of the microscope head, then a suitable adapter must be fitted.

In general there are two C-mount adapters available for this (1x and 0.57x magnification, see Chapter 3 Features). After fitting one of these adapters it can be fixed with the fixing screw. A camera which has a C-mount thread is then screwed on top of the adapter.

We recommend that you first adjust the field of view using the eyepieces on the device for the existing requirements, and then carry out the observation using the microscope camera (i.e. using the PC screen which is connected).

To do this, the trinocular toggle rod on the righthand side of the microscope head must be pulled out. The light from the microscope lighting is deflected so that it is completely in the beam path for the camera, which causes a dark field of view in the eyepieces. This means that it is not possible to simultaneously observe by the eyepieces and PC screen.

For C-mount adapters, which have their own integrated magnification, the image which is shown on the camera connected to the device can often have a different level of focus compared with the image on the eyepiece.

In order to be able to bring both images into focus, the focus can be adjusted by those adapters

14 Troubleshooting

Problem	Possible causes
The bulb does not light	The mains plug is not correctly plugged in
	There is no power at the socket
	Defective bulb
	Defective fuse
The bulb blows immediately	The specified bulb or fuse has not been used
The field of view is dark	The aperture diaphragm and/or field diaphragm are not opened wide enough
	The selector switch for the beam path is set to "Camera"
	The condenser is not correctly centred
You cannot adjust the brightness	The brightness control has been set incorrectly
	The condenser has not been correctly centred
	The condenser is too low
The field of view is dark or is not correctly illuminated	The objective is not positioned correctly on the beam path
	The selector switch for the beam path is between two settings
	The nosepiece is not correctly fitted
	The condenser is not correctly fitted
	An objective is being used which doesn't match the lighting area of the condenser
	The condenser has not been correctly centred
	The field diaphragm is closed too tightly
	The bulb is not correctly fitted
The field of view of one eye does not match that of the other eye	The interpupillary distance is not correctly adjusted
	Dioptré setting has not been carried out correctly
	Different eyepieces are used for the righthand and lefthand side
	The eyes are not used to using a microscope

Problem	Possible causes
Blurred details Bad image Bad contrast Vignetted field of view	The aperture diaphragm is not opened wide enough
	The condenser is too low
	The objective does not belong to this microscope
	The front lens of the objective is dirty
	An immersion object has been used without immersion oil
	The immersion oil contains air bubbles
	The condenser is not correctly centred
	The recommended immersion oil has not been used
Dirt or dust in the field of view	Dirt / dust on the objective
	Dirt /dust on the front lens of the condenser
	Dirt / dust on the eyepieces
	Dirt / dust on the front lens of the condenser
One side of the image is blurred	Dirt / dust on the object
	The stage was not correctly fitted
	The objective is not positioned correctly on the beam path
	The nosepiece is not correctly fitted
The image flickers	The upper side of the object is facing down
	The nosepiece is not correctly fitted
	The objective is not positioned correctly on the beam path
The coarse adjustment knob is difficult to turn	The condenser has not been correctly centred
	The rotational resistance brake is too tight
The stage moves down on its own The fine adjustment knob moves on its own	The angle table is blocked by a solid body
	The rotational resistance brake is not tight enough

When you move the table, the image becomes blurred

The stage was not correctly fitted

15 Service

If, despite studying these operating instructions, you still have questions about commissioning or operation, or if, contrary to expectations, a problem should occur, please contact your specialist dealer. The device may only be opened by trained service technicians authorized by KERN.

16 Power supply

16.1 Mains connection



The microscope may only be connected to the mains if the information on the microscope (sticker) and the local mains voltage are identical.



Important:

- Check the mains cable for damage before commissioning
- Ensure that the power supply unit does not come into contact with liquids
- The mains plug must be accessible at all times.

17 Maintenance, servicing and disposal



Disconnect the appliance from the power supply before carrying out any maintenance, cleaning or repair work.

17.1 Cleaning

The appliance must always be kept clean and regularly freed from dust.

Before wiping the appliance when it gets wet, make sure that the power is switched off.

Glass components should preferably be wiped lightly with a lint-free cloth if they become dirty.

To wipe oil stains or fingerprints from lens surfaces, the lint-free cloth is moistened with a mixture of ether and alcohol (70/30 ratio) and then cleaned

Ether and alcohol must always be handled with care as they are highly flammable substances. It is therefore essential to keep them away from naked flames and electrical appliances that are switched on and off and only use them in well-ventilated rooms.

However, organic solutions of this type should not be used to clean other components of the appliance. This could cause changes to the paintwork. It is sufficient to use a neutral cleaning agent for this purpose.

Other cleaning agents for the optical components include

- Special cleaner for optical lenses
- Special optical cleaning cloths
- Bellows
- Brush

If handled correctly and checked regularly, the microscope will function smoothly for many years.

17.2 Maintenance and repair

Do not make any modifications to the device or install spare parts. Contact the manufacturer for repair or device inspection.

17.3 Waste disposal



Old appliances and accessories must not be disposed of with household waste.

The operator must dispose of the packaging and the device at the place of use in accordance with the applicable national or regional legislation. The device consists of various components and materials, such as

- Electronic components (printed circuit boards, electrical cables)
- Plastic (housing)
- Metal

Improper disposal of the appliance can have harmful effects on people and the environment.

Proper and environmentally friendly disposal can prevent harmful effects and recover raw materials.

18 Further information

The illustrations may differ slightly from the product.

The descriptions and illustrations in these operating instructions are subject to change without notice. Further developments to the device may result in such changes.



All language versions include a non-binding translation.
The original German document is binding.