

Operating manual Analogue refractometer

KERN ORA 4 FA/FB Analogue Antifreeze VW Standard



Version 1.1 05/2016

KERN & Sohn GmbH

CONTENTS

1	Technical data.....	1
2	Description.....	2
3	General information.....	3
3.1	Intended use.....	3
3.2	Warranty.....	3
4	Basic safety information.....	4
4.1	Follow the instructions in the operating manual.....	4
4.2	Warning.....	4-5
5	Supplied items.....	5
6	Before the first use.....	6
7	Use/measurement.....	6
7.1	Zero point calibration.....	7-8
7.2	Additional advice.....	9
7.3	Measuring procedure for antifreeze testing.....	9-10
7.4	Measuring procedure for windscreen wiper water testing.....	10
7.5	Measuring procedure for determining battery acid density.....	11
8	Cleaning and maintenance.....	12
9	Storage.....	13
10	Service.....	13
11	Disposal.....	13
12	Additional information.....	13

1. Technical data

Modell KERN	Measuring range and Scales	Scale graduations Accuracy	Dimensions Product	Net weight
ORA 4 FA/FB	EG: -50°C – 0°C G13	1°C	160x40x40mm	0,140kg
	PG: -50°C – 0°C G11/12	1°C		
	CW: -40°C – 0°C	5°C		
	BF: 1,10 – 1,40 kg/l	0,01 kg/l		

Example scale on
ORA 4 FB



1

2. Description

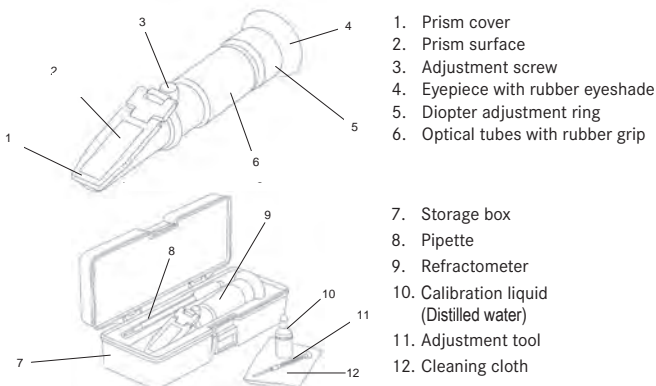

1. Prism cover
2. Prism surface
3. Adjustment screw
4. Eyepiece with rubber eyeshade
5. Diopter adjustment ring
6. Optical tubes with rubber grip
7. Storage box
8. Pipette
9. Refractometer
10. Calibration liquid (Distilled water)
11. Adjustment tool
12. Cleaning cloth

2

3. General information

3.1 Intended use

The refractometer is a measuring instrument for determining the refractive index of transparent substances in the liquid or the solid state. It is used to observe the behaviour of light as it passes from a prism with known properties to the substance being tested.

Use of the refractometer for other purposes is contrary to its intended use and may be hazardous. The manufacturer shall not be liable for any damages caused by improper use.

3.2 Warranty

The warranty shall be void in the event of:

- ▶ Failure to observe the instructions in the operating manual
- ▶ Use for purposes other than those described
- ▶ Modifications or opening the device housing
- ▶ Mechanical damage and/or damage resulting from media, liquids, natural wear and tear

3

4. Basic safety information

4.1 Follow the instructions in the operating manual



- ▶ Carefully read through the operating manual even if you have prior experience with KERN refractometers.
- ▶ Every language version includes a non-authoritative translation. The original German document is the definitive version.

4.2 Warning

- ▶ Do not let acids come into contact with skin or eyes. If acid comes into contact with skin, flush with copious amounts of water. Shower if larger areas of skin are affected.
- ▶ If acid comes into contact with eyes, keep the eyelid open and flush the eye with running lukewarm water from the outer corner to the inner corner. Flush eyes for at least 15 minutes. Then consult a doctor or ophthalmologist immediately.
- ▶ Thoroughly clean the refractometer after each use.
- ▶ The refractometer must not be exposed to extreme temperatures, high mechanical stresses, strong direct sunlight or high humidity.
- ▶ This refractometer is not a toy. Keep out of reach of children.
- ▶ Make sure that you will not be hit by anything else while you are using the refractometer, as this could cause serious eye injuries
- ▶ The rubber eyeshade may cause irritation when in prolonged contact with the skin. If this happens, consult your doctor.
- ▶ Do not touch the lenses with your fingers.

4

5. Supplied items

After unpacking and before using the device for the first time, check that all listed parts have been supplied. Replace damaged or faulty parts immediately and do not put them into operation.

- ▶ Refractometer
- ▶ Storage box
- ▶ Pipette
- ▶ Adjustment tool
- ▶ Cleaning cloth
- ▶ Calibration liquid (Distilled water)

5

6. Before the first use

Remove the protective film (if present) from the prism surface [2] and check that the rubber eye-cup [4] is fitted correctly.

7. Use/measurement

The refractometer can be used to quickly and accurately determine the refractive index of transparent substances, liquid or solid ones. To ensure correct measurement, the measuring device should be adjusted before measurements are carried out. Please make sure your hands are dry before handling the measuring device.

7.1 Zero point calibration

- ▶ Hold up the refractometer against a sufficiently bright light source and look through the eyepiece [5], holding the rubber eyeshade [4] closely against your eye/glasses.
 - ▶ Rotate the eyepiece [5] to adjust it for your eyesight, until you can see the scale sharply.
 - ▶ Open the prism cover [1].
 - ▶ Thoroughly clean the prism [2] and the underside of the prism cover [1] using a soft cloth or soft paper (with alcohol if necessary) and wipe dry.
 - ▶ Now apply a few drops of the calibration liquid [10] onto the prism surface [2].
 - ▶ Close the prism cover [1]. The amount of fluid should be sufficient to moisten most of the prism surface. There should not be any air bubbles between the measuring prism [2] and prism cover [1].
 - ▶ Wait about 30 seconds to allow the temperatures of the fluid and prism to equalise.
 - ▶ Look through the eyepiece [4] while pointing the refractometer's prism surface [2] at a bright light source.
 - ▶ Through the eyepiece [4], you will see a bright and a blue field. The boundary line between them shows the measured value on the scale which is also visible through the eyepiece [4].
- 7
- ▶ Use the supplied adjustment tool [11] to turn the adjustment screw [3] behind the prism surface [2] (under the rubber cap), and adjust the scale so that the measuring device is optimally set up by moving the boundary line upwards or downwards. Calibration value ORA 4FA/4FB: 0 °C EG / PG / CW
- ▶ Repeat step 4 (cleaning).

Important!

The ambient/room temperature and the sample temperature influence the refractometer measuring result. The scales of the refractometer models, which have "FB" in its name, are designed for an ambient temperature of +20 °C! If the measurements are carried out at a temperature other than +20 °C, the results must be correspondingly corrected. Refractometer models, which have "FA" in its name, are equipped with an automatic temperature compensation (ATC). Between +10°C and +30°C measurement differences due to temperature changes are automatically compensated.



8

7.2 Additional advice

It is important that the samples being measured are representative samples. For samples that evaporate easily, measurements should be carried out quickly. The samples should be at the same temperature as the measuring instrument in order to achieve an accurate result.

7.3 Measuring procedure for antifreeze testing

- ▶ Open the prism cover [1] and use the supplied pipette [8] to apply a few drops of the sample coolant [8] onto the prism surface [2], then close the prism cover [1]. Spread the liquid evenly by pressing down on the prism cover [1] and eliminate any air bubbles present.
 - ▶ Close the prism cover [1] and view the measurement scale through the eyepiece [4]. Point the prism surface [2] of the refractometer at a bright light source while doing this.
 - ▶ Rotate the adjustment ring [5] on the eyepiece [4] to adjust the focus.
 - ▶ The boundary line will move on the measurement scale depending on the antifreeze concentration. This light/dark boundary on the antifreeze scale [B] directly indicates the freezing point of the antifreeze mixture in °C. The figures show the measured value for propylene* (G13) and the measured value for ethylene** (G11/G12). If the antifreeze used is not known or it is a mixture of both, the propylene scale must always be used. Only then can sufficient coolant antifreeze protection be reliably guaranteed.
 - ▶ The measurement result is not influenced by the temperature of the coolant.
 - ▶ Carefully clean the supplied pipette [8] and the refractometer after carrying out the measurement.
- 9

7.4 Measuring procedure for windscreen wiper water testing

- ▶ The measuring procedure is identical to that for antifreeze testing.
 - ▶ The measured value can be read off the windscreen wiper water testing scale [C] in °C and provides a guide value, because the composition of the individual antifreeze agent varies.
 - ▶ Carefully clean the supplied pipette [8] and the refractometer after carrying out the measurement.
- 10

7.5 Measuring procedure for determining battery acid density

- ▶ Instead of antifreeze solution, place some battery acid on the prism surface [2] using the pipette [10].
 - ▶ Using the light/dark boundary on the measuring scale for determining battery acid density [A] „-“ / „+“, read off the acid density in g/cm³ (kg/l).
 - ▶ The scale [A] is divided into three regions for determining the charge condition.
- | | | |
|----------|---|--|
| RECHARGE | = | replace/recharge (<1.20 g/cm ³);
Charge ~50% |
| FAIR | = | acceptable (1.20 to 1.25 g/cm ³);
Charge ~75% |
| GOOD | = | good (>1.25 g/cm ³);
Charge ~100% |

* Propylenes are preferentially used as antifreezes in the European region.

** Ethylenes are preferentially used as antifreezes outside of the European region.

Important!

After every measurement, use a lint-free, absorbent cloth to remove the fluids from the prism surface [2] and prism cover [1]. Then carefully clean the prism and prism cover using a cloth moistened with water or if necessary alcohol, and dry both parts using a soft, dry and lint-free cloth. Avoid rubbing the prism [2].



11

8. Cleaning and maintenance

Clean the refractometer using a soft, lint-free cloth moistened with either water or, if necessary, alcohol. Do not use any aggressive or abrasive cleaning agents. Never immerse the device in water or hold it under running water. Never handle the device with wet or damp hands.

Never touch the measuring prism [2] with hard tools made from plastic, wood, rubber, metal, glass etc. Hard objects can quickly damage the relatively soft prism glass, resulting in measurement errors.

The refractometer is maintenance-free.

Cleaning should be carried out immediately before and after each use of the refractometer to maximise its life and optimise measurement results.

12

9. Storage

Store the refractometer in a dry, non-corrosive environment, preferably between 10 °C and 30 °C.

10. Service

After reading this operating manual, if you have any questions about setting up or using the refractometer, or if any unexpected problem occurs, please contact your dealer. The device housing may only be opened by trained service technicians authorised by KERN.

11. Disposal

The packaging consists of environmentally friendly materials which can be disposed of via local recycling facilities.

The device and storage box should be disposed of by the operator in accordance with applicable national or regional regulations at the place of use.

12. Additional information

The product may differ slightly from the illustrations. Avoid exposing the refractometer to direct sunlight. Never bring the refractometer into contact with solvents.

13