



Sauter GmbH

# Instruction Manual / Data sheet

**CT Q1**

V. 1.0  
12/2018  
EN



PROFESSIONAL MEASURING

CT Q1-BA-e-1810



# SAUTER CT Q1

V. 1.0 12/2018

## Instruction Manual / Data sheet

---

---

Summarize:

<b>1</b>	<b>Short description .....</b>	<b>3</b>
<b>2</b>	<b>Available models.....</b>	<b>3</b>
<b>3</b>	<b>Introduction.....</b>	<b>3</b>
<b>4</b>	<b>Warning notes .....</b>	<b>3</b>
<b>5</b>	<b>Warranty .....</b>	<b>4</b>
<b>6</b>	<b>Detailed specifications .....</b>	<b>4</b>
<b>7</b>	<b>Wiring.....</b>	<b>4</b>
<b>8</b>	<b>Dimensions in mm.....</b>	<b>5</b>
<b>8.1</b>	<b>Dimensions in mm (300kg -5000kg) .....</b>	<b>5</b>
<b>8.2</b>	<b>Dimensions in mm (7500kg -10000kg) .....</b>	<b>5</b>
<b>9</b>	<b>Certificate of Compliance.....</b>	<b>5</b>

## 1 Short description

- Stainless steel IP68 (acc. to EN 60529) / IP69K (acc. to ISO 20653) shear beam load cell
- Suitable platform, hopper, bed and other weighing devices in raw environment
- hermetically sealed
- Accuracy OIML R60 C3
- OIML certificated
- RoHS conform
- Option on request: EX

## 2 Available models

Capacity	Model
300kg	CT 300-3Q1
500kg	CT 500-3Q1
750kg	CT 750-3Q1
1000kg	CT 1000-3Q1
1500kg	CT 1500-3Q1
2000kg	CT 2000-3Q1
3000kg	CT 3000-3Q1
5000kg	CT 5000-3Q1
7500kg	CT 7500-3Q1
10000kg	CT 10000-3Q1

## 3 Introduction

Please pay attention to the notes of the operating manual: read these operating manual carefully before commissioning, even if you already have experience with SAUTER measuring cells.

After receiving the measuring cell, it should be checked in advance whether no transport damage has occurred, whether the outer packaging or other parts or even the article itself has been damaged. If any damage is evident, please inform SAUTER GmbH immediately.

## 4 Warning notes

Observe the national accident prevention regulations.

Not correct executed use of the measuring cell can lead to serious injuries, death, material damage and personal injuries. Use only by trained and experienced people. Never load more than the max. capacity to a measuring cell. Overloaded measuring cells no longer have the required accuracy. Overloaded or deformed measuring cells are no longer allowed to use and must be changed quickly.

Never step under suspended loads.

Always fasten overload- or break security to your construction.

Pay attention to the allowed static and dynamic loads of the used equipment.

Let the measuring cells calibrate at regular intervals.

Only load the measuring cell in its specified load direction. Avoid lateral forces.

Control the measuring cells to deformations and cracks.

Measuring cells with 4-Conductor cable will change their characteristic value when shortened or extended the cable length.

## 5 Warranty

The warranty expires at:

- Disregard of the specifications of the operating manual
- Modification or opening the measuring cell
- Overload
- Mechanical damages
- Damage caused by liquids or media
- Natural loss
- Not correct installation

## 6 Detailed specifications

Output sensitivity ( FS )	mV/V	2.0 ± 0.001
Maximum capacity ( Emax )	kg	300, 500, 750, 1000, 1500, 2000, 3000, 5000, 7500, 10000
Max.number of load cell intervals	nLC	3000
Ratio of min. LC verification interval	Y = Emax / vmin	10000
Combined Error	%FS	≤± 0.017
Minimum dead load	Of Emax	0%
Safe overload	of Emax	150 %
Ultimate overload	of Emax	200 %
Zero balance	of FS	< ± 2.0 %
Excitation, recommended voltage	V	10 ~ 15
Input resistance	Ω	400 ± 20
Output resistance	Ω	350 ± 3
Insulation resistance	MΩ	≥5000 ( at 50VDC )
Compensated temperature	°C	-10 ~+40
Operating temperature	°C	-35 ~ +65

## 7 Wiring

Shielded, 6 cable. Shield not connected to element.

Cable diameter: Ø6mm.

Standard cable length for 300kg – 5000kg: 5m

Standard cable length for 7500kg – 10000kg: 10m

6-wire diagram

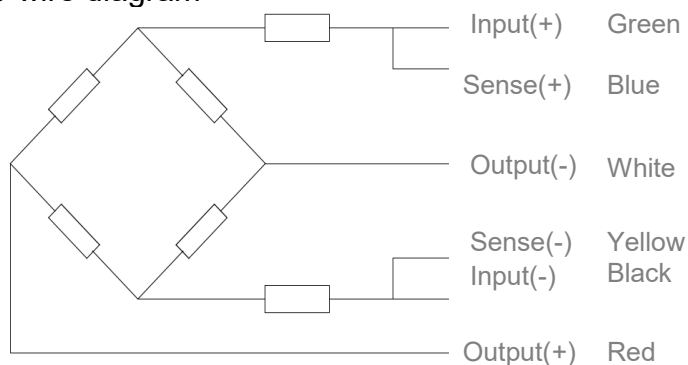

## 8 Dimensions in mm

### 8.1 Dimensions in mm (300kg -5000kg)

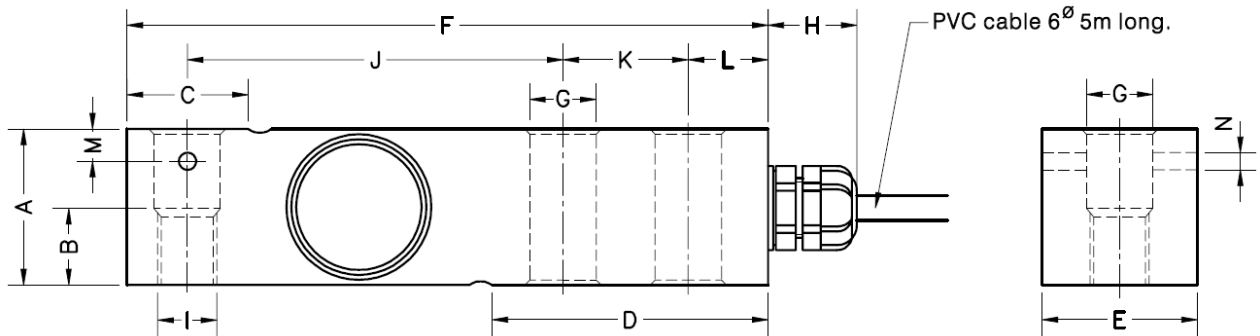

Dimension Capacity	A	B	C	D	E	F	G Ø	H	I	J	K	L	M	N Ø
300kg – 2000kg	31,5	15	24,6	56	31,5	130	13,5	18	M12	76,2	25,4	15,8	6,5	3,5
3000kg -5000kg	48		37	79	41,5	171,5	20,5	18	20,5	95,2	38,1	19		

### 8.2 Dimensions in mm (7500kg -10000kg)

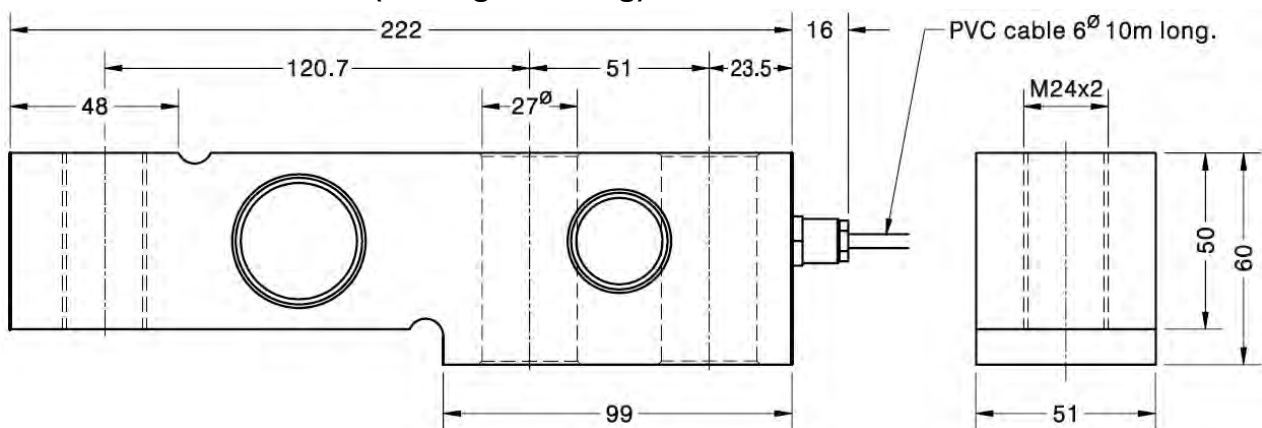

## 9 Certificate of Compliance

The Certificate of Compliance can be downloaded from the website [www.sauter.eu](http://www.sauter.eu)