



Sauter GmbH

User manual / Data sheet

SAUTER DC Y1

V. 1.0
11/2020
GB



PROFESSIONAL MEASURING

DC Y1-BA-e-2010.docx



SAUTER DC Y1

V. 1.0 11/2020

User manual / Data sheet

Summarize:

1	Brief description	3
2	Available models.....	3
3	Introduction.....	3
4	Warnings	3
5	Warranty	4
6	Technical data.....	4
7	Electrical connection.....	4
8	Dimensions in mm.....	5
9	Declaration of conformity	5

1 Brief description

- Alloy steel static torque sensor
- High precision (comprehensive error 0.5% F.S.)
- RoHS compliant

Suitable e.g.

- for monitoring or measuring static torques
- Test manual torque wrench, transfer of static load torques

2 Available models

Nominal load	Model
5 Nm	DC 5-Y1
10 Nm	DC 10-Y1
20 Nm	DC 20-Y1
50 Nm	DC 50-Y1
100 Nm	DC 100-Y1
200 Nm	DC 200-Y1
500 Nm	DC 500-Y1

3 Introduction

Please observe the notes in the operating instructions: Please read this operating manual carefully before commissioning, even if you already have experience with SAUTER measuring cells.

After receipt of the measuring cell, it should be checked in advance to ensure that no transport damage has occurred, that the repackaging or other parts or even the article itself have not been damaged. If any damage is evident, please notify SAUTER GmbH immediately.

4 Warnings

Observe the national accident prevention regulations.

Incorrect use of the measuring cells can lead to serious injury, death, damage to property and personal injury. Use may only be carried out by trained and experienced personnel.

Never load measuring cells beyond the range E_{max} (nominal load, max. capacity). Overloaded measuring cells no longer have the required accuracy. Overloaded or deformed measuring cells must not be used any further and must be replaced immediately.

Never step under suspended loads.

Always install overload or breakage protection on your system.

Always observe the permissible static and dynamic loads of the accessories you use.

Have measuring cells calibrated at regular intervals.

Only load the measuring cell in the direction indicated. Avoid lateral forces.

Check the measuring cells regularly for deformations and cracks.

For measuring cells with 4-wire connection, the characteristic value changes by shortening or lengthening the supplied cable.

5 Warranty

The warranty expires with:

- Disregarding the instructions in the operating manual
- Change or open the measuring cell
- Overload
- Mechanical damage
- Damage by liquids or media
- Natural wear and tear
- Improper setup or electrical installation

6 Technical data

Output sensitivity (FS)	mV/V	1.0 ... 1.5mV/V
Maximum capacity (Emax)	Nm	
Comprehensive Error	%F. S.	≤± 0.5
Zero balance	%F.S.	± 1
Creep	%F.S./30min	± 0.05
Temperature effect on span	%F.S./10°C	± 0.05
Temperature effect on Zero	%F.S./10°C	± 0.05
Safe overload	of Emax	120 %
Ultimate overload	of Emax	150 %
Excitation, recommended voltage	V	9 ~ 12
Input resistance	Ω	700 ± 5
Output resistance	Ω	750 ± 15
Insulation resistance	MΩ	≥5000
Operating temperature	°C	-20 ~ +65

7 Electrical connection

Shielded cable, shield not connected to element, cable diameter Ø5mm,

Standard cable length: 3m

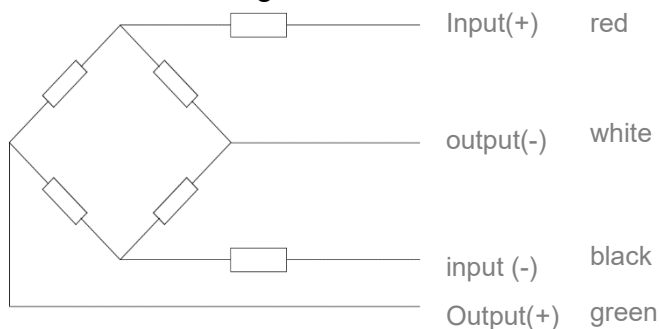

8 Dimensions in mm

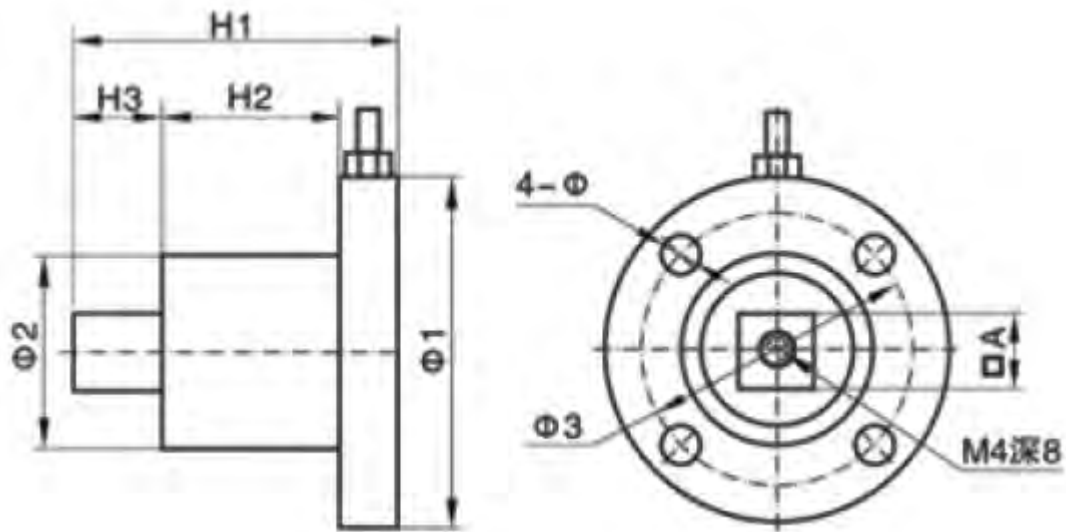

Range	A	H1	H2	H3	Φ1	Φ2	Φ3	Φ
2...200Nm	12,5	55	30	15	59	32	45	6,5
300...500Nm	25,4	75	40	24	68	40	55	8,5

9 Declaration of conformity

To view the CE declaration, please click on the following link:

<https://www.kern-sohn.com/shop/de/DOWNLOADS/>