

Defender™ 3000 Indicators Instruction Manual

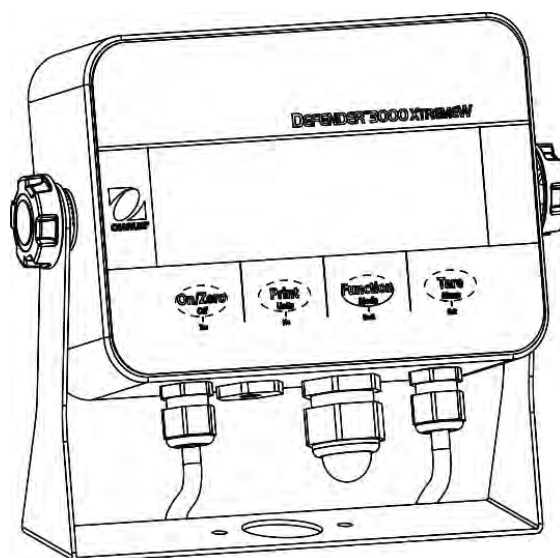

i-DT33P



i-DT33XW

Table of Contents

1.	INTRODUCTION	3
1.1.	Safety Precautions	3
1.2.	Intended Use	3
1.3.	Overview of Parts and Controls	4
1.4.	Mainboard	5
1.5.	Control Functions	6
2.	INSTALLATION.....	8
2.1	Unpacking	8
2.2	External Connections	8
2.2.1	Battery Power Supply	8
2.2.2	AC Power Supply.....	8
2.3	Internal Connections	9
2.3.1	Open the Housing.....	9
2.3.2	EasyConnect™ Indicator	13
2.3.3	Non-EasyConnect™ Indicator	13
2.3.4	i-DT33P RS232 Connection	17
2.3.5	i-DT33XW RS232 Connection.....	17
2.4	Mounting Bracket	18
3.	OPERATION.....	19
3.1	Turning the Scale On/Off	19
3.2	Weighing Mode	19
3.2.1	Enter the Mode and Start Weighing	19
3.2.2	Application Settings	19
3.3	Counting Mode	20
3.3.1	Enter the Mode	20
3.3.2	Start Counting	20
3.3.3	Application Settings	20
3.4	Check	20
3.4.1	Set Check Limits.....	21
3.4.2	Positive Check.....	21
3.4.3	Negative Check.....	21
3.4.4	Zero Check.....	22
3.4.5	Application Settings	22
3.5	Totalization	23
3.5.1	Application Settings	23
3.5.2	Enter the Mode	23
3.5.3	Totalization Method.....	23
3.5.4	View Totalization Result.....	23
3.5.5	Totalization Rules.....	24
3.5.6	Print Totalization Result and Format	24
3.5.7	Application Settings	25
3.6	Skip.....	25
4.	MENU SETTINGS	26
4.1	Menu Navigation	26
4.1.1	User Menu (in segments)	26
4.1.2	Button Navigation.....	27
4.2	Calibration Menu	28
4.2.1	Initial Calibration.....	28
4.2.2	Zero Calibration [ZER].....	28
4.2.3	Span Calibration [SPAN].....	28
4.2.4	Linearity Calibration [L #].....	29
4.2.5	GEO Code Adjustment [GEO].....	29
4.2.6	Calibration Test [L.E.E.S.E]	30
4.2.7	End Cal [End]	30
4.3	Setup Menu	31
4.4	Readout Menu	33
4.5	Unit Menu	35
4.6	Communication	35
4.6.1	RS232 Menu	35

4.6.2	Print Menu.....	37
4.6.3	USB Configuration.....	39
4.6.4	Ethernet Configuration.....	39
4.7	Lock Button Configuration.....	40
5.	LEGAL FOR TRADE.....	41
5.1	Settings.....	41
5.2	Verification.....	41
5.3	Sealing.....	42
5.3.1	Sealing for Base without EasyConnect.....	42
5.3.2	Sealing for an EasyConnect Base with Memory Module.....	42
6.	MAINTENANCE.....	43
6.1	Cleaning.....	43
6.2	Troubleshooting.....	43
6.3	Service Information.....	44
7.	TECHNICAL DATA.....	45
7.1	Specifications.....	45
7.2	Accessories and Options.....	46
7.3	Table of Geo Code Values.....	47
8.	COMPLIANCE.....	48
9.	APPENDICES.....	50
9.1	Appendix A.....	50
9.2	Appendix B.....	52
9.3	Appendix C.....	53
9.4	Appendix D.....	54
	LIMITED WARRANTY.....	55

1. INTRODUCTION

This manual contains installation, operation and maintenance instructions for i-DT33P and i-DT33XW indicators. Please read it completely before installation and operation.

1.1. Safety Precautions

Definition of Signal Warnings and Symbols

Safety notes are marked with signal words and warning symbols. These show safety issues and warnings. Ignoring the safety notes may lead to personal injury, damage to the instrument, malfunctions and false results.

WARNING	For a hazardous situation with medium risk, possibly resulting in severe injuries or death if not avoided.
CAUTION	For a hazardous situation with low risk, resulting in damage to the device or the property or in loss of data, or minor or medium injuries if not avoided.
ATTENTION	For important information about the product. May lead to equipment damage if not avoided.
NOTE	For useful information about the product.

Warning Symbols



General hazard



Explosion hazard



Electrical shock hazard

Safety Precautions



CAUTION: Read all safety warnings before installing, making connections, or servicing this equipment. Failure to comply with these warnings could result in personal injury and/or property damage. Retain all instructions for future reference.

- Before connecting power, verify that the equipment's input voltage range and plug type are compatible with the local AC mains power supply.
- Do not position the equipment such that it is difficult to reach the power connection.
- Only connect the power cord to a compatible grounded electrical outlet.
- Only use a power cord with a rating that exceeds the specifications on the data label. (for i-DT33P)
- Make sure that the power cord does not pose a potential obstacle or tripping hazard.
- Operate the equipment only under ambient conditions specified in these instructions.
- The equipment is for indoor use only.
- Do not operate the equipment in hazardous or unstable environments.
- Do not allow liquids to enter the equipment.
- Use only approved accessories and peripherals.
- Disconnect the equipment from the power supply when cleaning.
- Service should only be performed by authorized personnel.



WARNING: Never work in an environment subject to explosion hazards! The housing of the instrument is not gas tight. (Explosion hazard due to spark formation, corrosion caused by the ingress of gases).



WARNING: Electrical shock hazards exist within the housing. The housing should only be opened by authorized and qualified personnel. Remove all power connections to the unit before opening.



WARNING: If the indicator is connected to a base with a memory module, please make the connection before powering on. If the base is connected to a powered indicator, the memory module may be damaged because it includes an electrostatic sensitive chip.

1.2. Intended Use

This instrument is intended for use in laboratories, pharmacies, schools, businesses and light industry. It must only be used for measuring the parameters described in these operating instructions. Any other type of use and operation beyond the limits of technical specifications, without written consent from OHAUS, is considered as not intended. This instrument complies with current industry standards and the recognized safety regulations; however, it can constitute a hazard in use. If the instrument is not used according to these operating instructions, the intended protection provided by the instrument may be impaired.

1.3. Overview of Parts and Controls

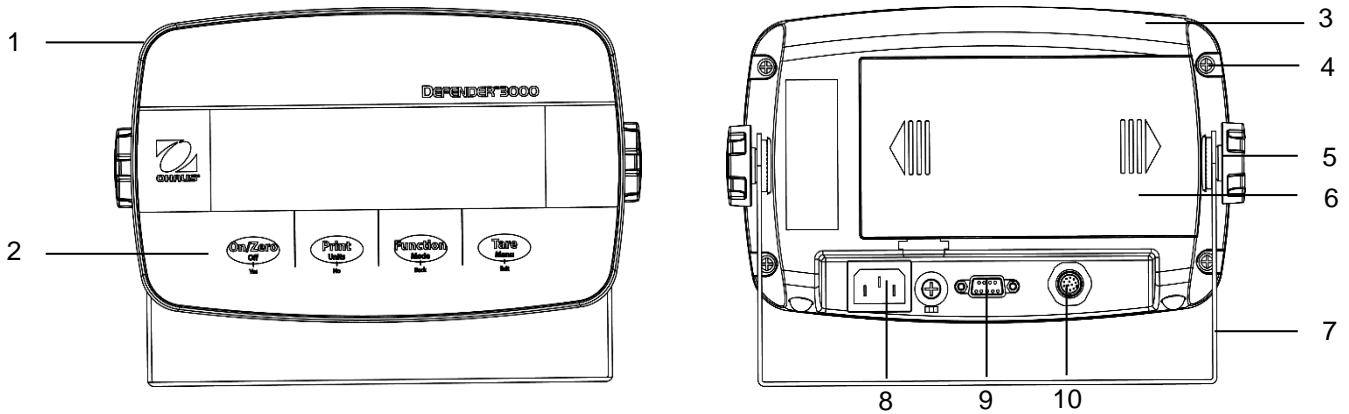

Figure 1-1 i-DT33P Indicator

Item	Description	Item	Description
1	Front Housing	6	Battery Cover
2	Control Panel	7	Mounting Bracket
3	Rear Housing	8	Power Cord Connector
4	Screws (5)	9	RS232 Connector
5	Adjusting Knobs (2)	10	Load Cell Connector

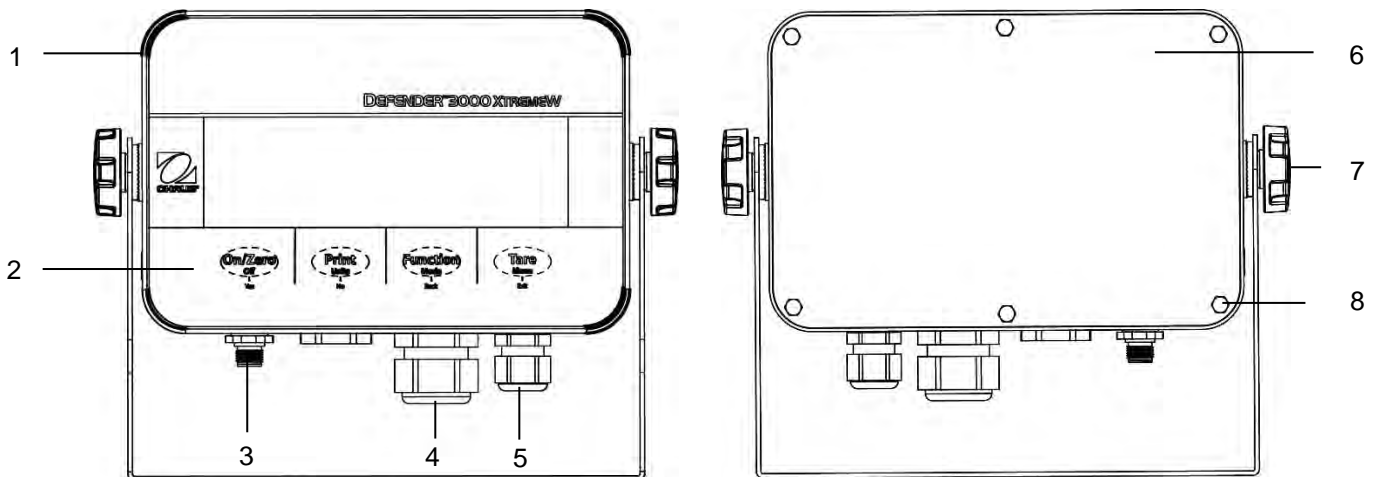

Figure 1-2 i-DT33XW Indicator

Item	Description
1	Front Housing
2	Control Panel
3	Load Cell Connector
4	Strain Relief for Option
5	Strain Relief for Power Cord
6	Rear Housing
7	Adjusting Knobs (2)
8	Hex Head Bolts (6)

Note:

- There are two types of load cell connector, one supports EasyConnect™ and one does not. Therefore the load cell connector varies for different models.
- For some i-DT33XW models, the position of load cell connector, strain relief for option and power cord may change. Please refer to the actual product.

1.4. Mainboard

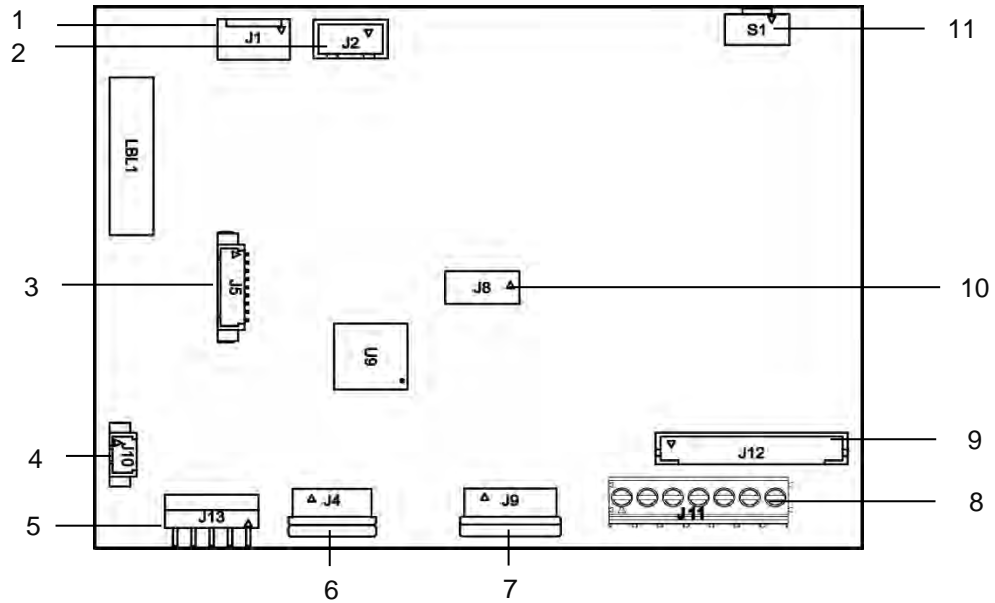

Figure 1-3 i-DT33P Mainboard

Item	Description	Item	Description
1	DC input (J1)	7	Display board connector (J9)
2	Dry cell input (J2)	8	Load cell terminal block (J11) (for models not supporting EasyConnect™)
3	Ethernet kit / USB device kit connector (J5)	9	Load cell connector (J12) (for models supporting EasyConnect™)
4	Backlight connector (J10)	10	Lead-acid battery charge board kit connector (J8)
5	RS232 connector (J13)	11	Security switch connector (S1)
6	Keyboard connector (J4)		

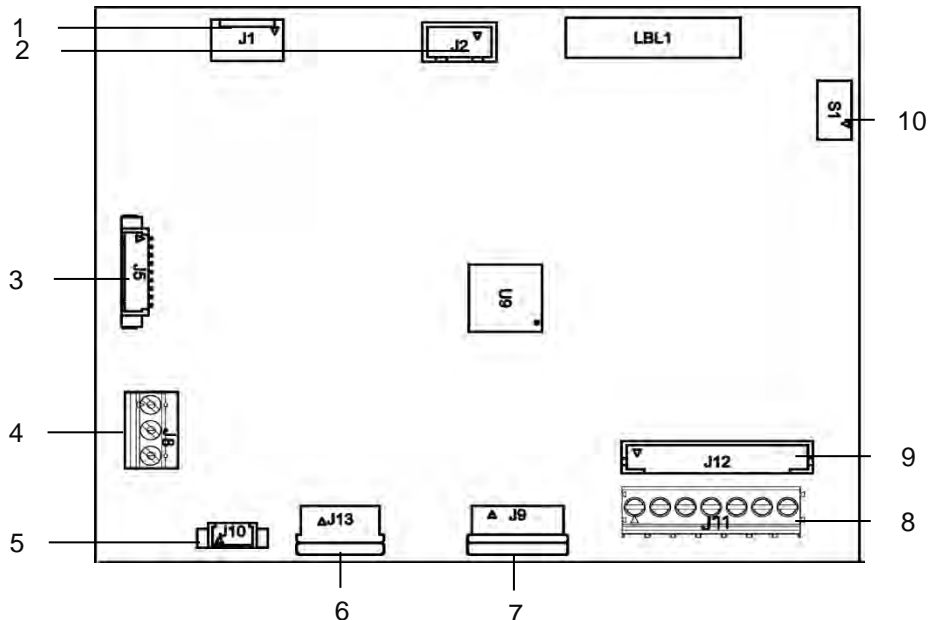

Figure 1-4 i-DT33XW Mainboard

Item	Description	Item	Description
1	DC input (J1)	6	Keyboard connector (J13)
2	Lead-acid battery input (J2)	7	Display board connector (J9)
3	Ethernet kit / USB device kit connector (J5)	8	Load cell terminal block (J11) (for models not supporting EasyConnect™)
4	RS232 connector (J8)	9	Load cell connector (J12) (for models supporting EasyConnect™)
5	Backlight connector (J10)	10	Security switch connector (S1)

Note: Mainboard may vary slightly for different regions.

1.5. Control Functions



Figure 1-5 i-DT33P Control Panel



Figure 1-6 i-DT33XW Control Panel

Button	On/Zero Off Yes	Print Units No	Function Mode Back	Tare Menu Exit
Primary Function (Short Press)	On/Zero If the terminal is off, press to power on; If the terminal is on, press to set the zero point.	Print Sends the current value to the RS232 port if the Print Setup → Assignment → Demand menu is enabled.	Function Initiates an application mode.	Tare Performs a tare operation.
Secondary Function (Long Press)	Off If the terminal is on, press to power off.	Units Changes the weighing unit.	Mode Changes the application mode.	Menu Enters the user menu. Shows a tare value in application modes.
Menu Function (Short Press)	Yes Accepts the current setting on the display or selects a sub-menu or menu item.	No Advances to the next menu or menu item. Rejects the current setting on the display and advances to the next available one.	Back Moves back to the previous menu item.	Exit Exits the user menu. Aborts a calibration in progress. Exits when displaying totalization result or under and over value in check mode.

Notes:

- Short Press: press less than 1 second.
- Long Press: press and hold for more than 3 seconds.

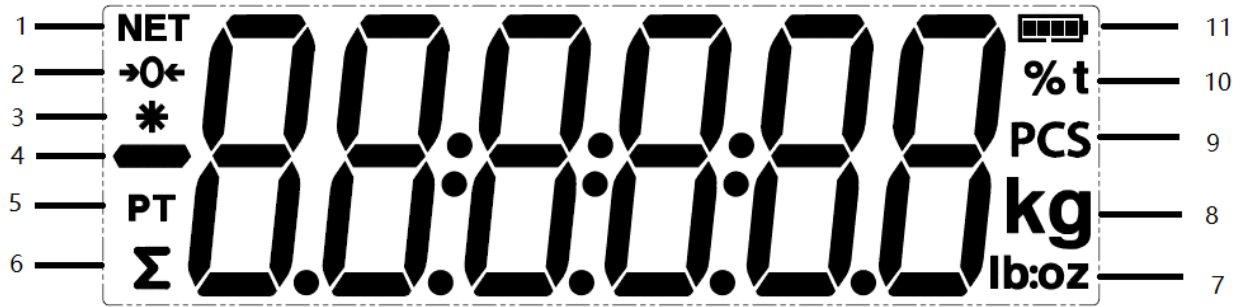

Figure 1-7 Display

Item	Description	Item	Description
1	NET symbol	7	Pound, Ounce, Pound:Ounce symbols
2	Center of Zero symbol	8	Kilogram, Gram symbols
3	Stable weight symbol	9	Pieces symbol
4	Negative symbol	10	Percent symbol, Tonne symbol
5	Preset tare symbol	11	Battery symbol
6	Totalization symbol		

2. INSTALLATION

2.1 Unpacking

Unpack the following items:

- i-DT33P or i-DT33XW indicator
- Rechargeable battery (i-DT33XW)
- Rechargeable battery (supplied in some regions for i-DT33P)
- Mounting bracket
- Knobs (2)
- Quick installation guide
- Instruction manual
- Jumper connector for 4-wire load cell cable (supplied for non-EasyConnect™ stand alone indicator)
- M16 strain relief gland (supplied for EasyConnect™ stand alone indicator)
- One ferrite core (supplied for non-EasyConnect™ stand alone indicator)

2.2 External Connections

2.2.1 Battery Power Supply

i-DT33P

Use 6 C size dry batteries (not included).

In some regions, the i-DT33P model comes with one lead-acid battery installed by factory.

Note: You can contact an authorized OHAUS dealer to buy the lead-acid battery as an option.

i-DT33XW

This model comes with one lead-acid battery installed by factory default.

Note: The lead-acid battery will charge automatically while connecting to the power supply. When charging, the battery level indicator increases or decreases in one grid, two grids, three grids and four grids. The battery level indicator will disappear when the battery is fully charged.

While operating on battery, the battery symbol indicates the battery status:



Battery 5%~25% remaining



Battery 25%~50% remaining



Battery 50%~75% remaining



Battery 75%~100% remaining



Attention: Before using the indicator for the first time, the internal rechargeable battery should be fully charged for up to 12 hours. The indicator can be operated during the charging process. The battery is protected against overcharging and the indicator can remain connected to the AC power line.



CAUTION: BATTERY IS TO BE REPLACED ONLY BY AN AUTHORIZED OHAUS SERVICE DEALER. RISK OF EXPLOSION CAN OCCUR IF THE RECHARGEABLE BATTERY IS REPLACED WITH THE WRONG TYPE OR IF IT IS NOT PROPERLY CONNECTED. DISPOSE OF THE RECHARGEABLE BATTERY ACCORDING TO LOCAL LAWS AND REGULATIONS.



Dispose of the lead acid battery according to local laws and regulations.

2.2.2 AC Power Supply

Connect the AC plug to an electrical outlet to power on the indicator. Connect the other end to the indicator if not connected.

2.3 Internal Connections

Some internal connections require to open the housing first. Therefore, please check the **Open the Housing** section below before making connections.



CAUTION: ELECTRICAL SHOCK HAZARD. REMOVE ALL POWER CONNECTIONS TO THE INDICATOR BEFORE SERVICING OR MAKING INTERNAL CONNECTIONS. THE HOUSING SHOULD ONLY BE OPENED BY AUTHORIZED AND QUALIFIED PERSONNEL, SUCH AS AN ELECTRICAL TECHNICIAN.

2.3.1 Open the Housing

2.3.1.1 i-DT33P

1. Turn the two knobs (circled) on each side of the indicator to disassemble the bracket.

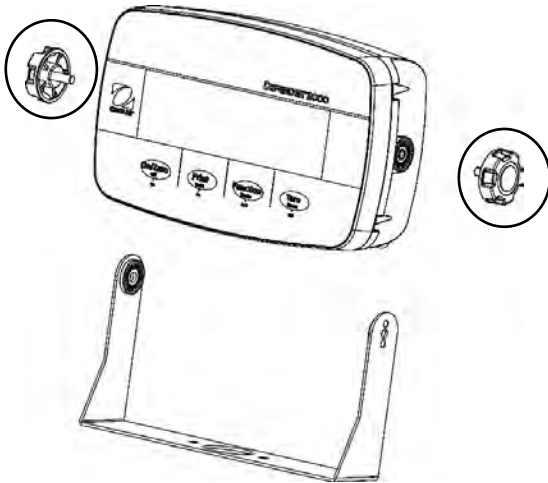

2. Remove the five screws (circled) from the rear housing.

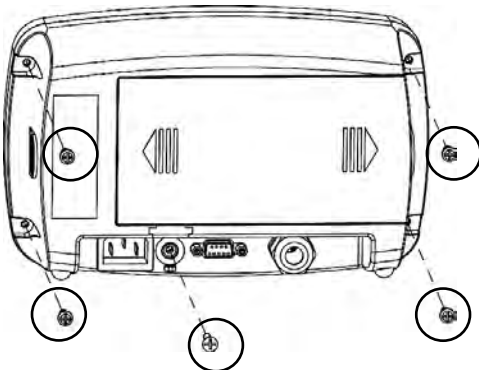

3. Open the rear housing.

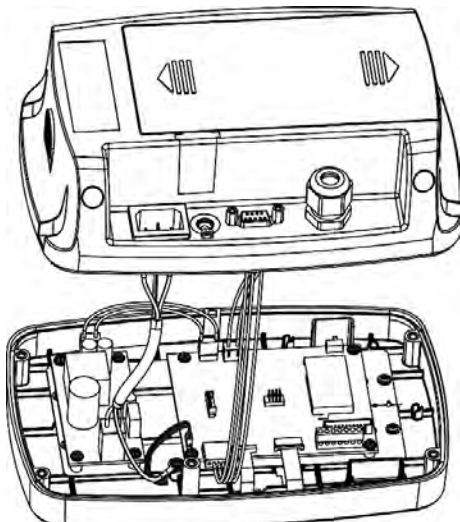

4. Close the housing and retighten the screws after finishing internal connections

Note: The screws should be tightened to 1 N•m (8-9 in-lb) torque.

2.3.1.2 i-DT33P (with Lead-acid Battery)

i-DT33P comes with a lead-acid battery installed in some regions. Please follow the instruction below for opening the housing and take out the battery.

Note: If your indicator does not contain the lead-acid battery but you want to purchase it as an accessory, you can contact an authorized OHAUS dealer to obtain it.

1. Remove the battery cover in the direction of the arrow.

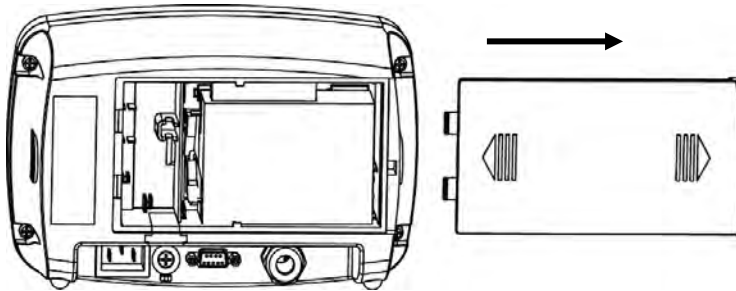

2. Take out the lead-acid battery (circled).

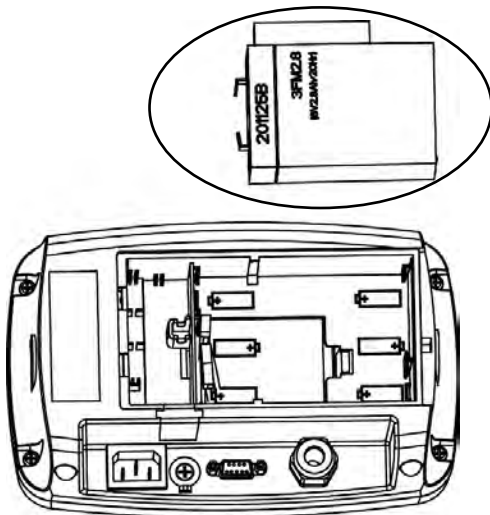

3. Slightly push the end of the charging cover (circled) in the direction of the arrow and take it out.

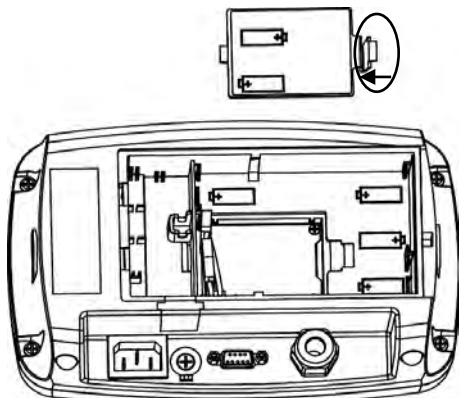

- Remove the two screws on the charging board (circled) and take it out.

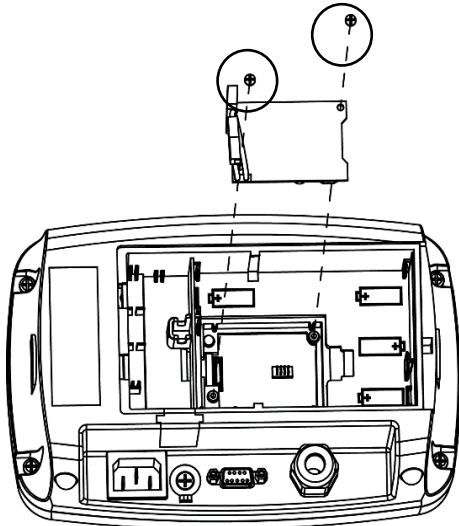

- Remove the five screws (circled) from the rear housing.

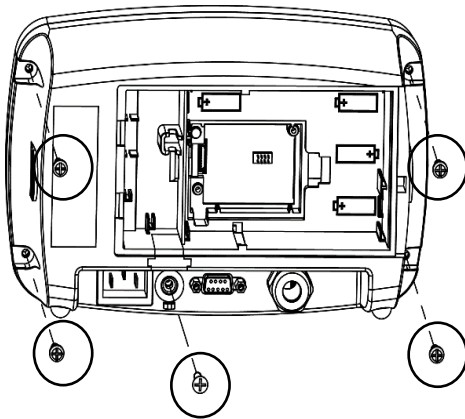

- Open the rear housing.

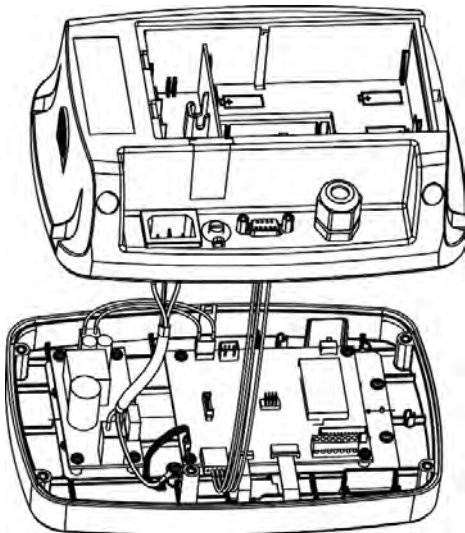

- Close the rear housing, retighten the screws and re-install the lead-acid battery after finishing internal connections

Note: The screws should be tightened to 1 N•m (8-9 in-lb) torque.

2.3.1.3 i-DT33XW

1. Turn the two knobs (circled) on each side of the indicator to disassemble the bracket.

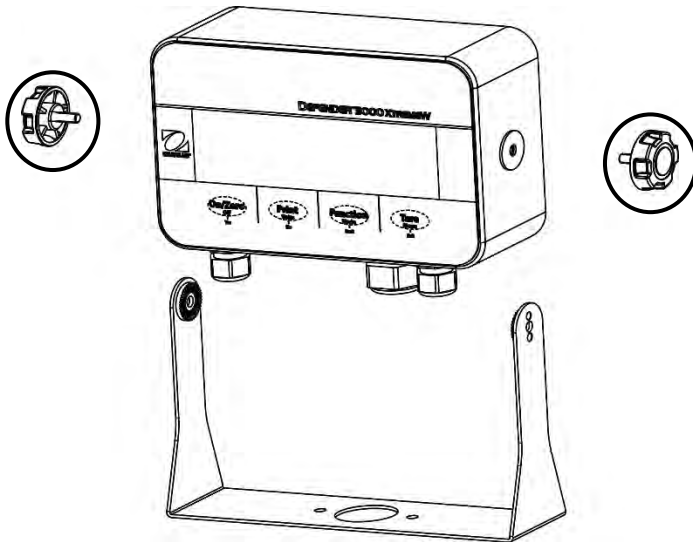

2. Remove the six hex head bolts from the rear housing of the indicator.

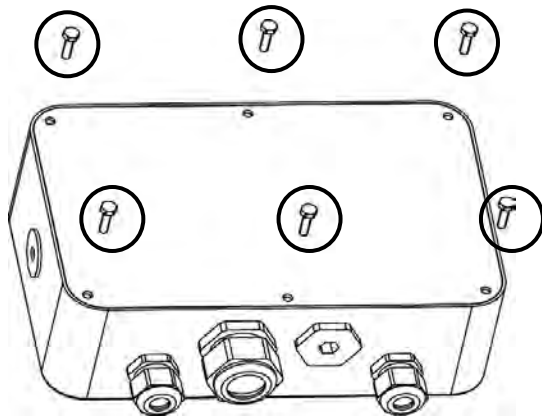

3. Open the rear housing.

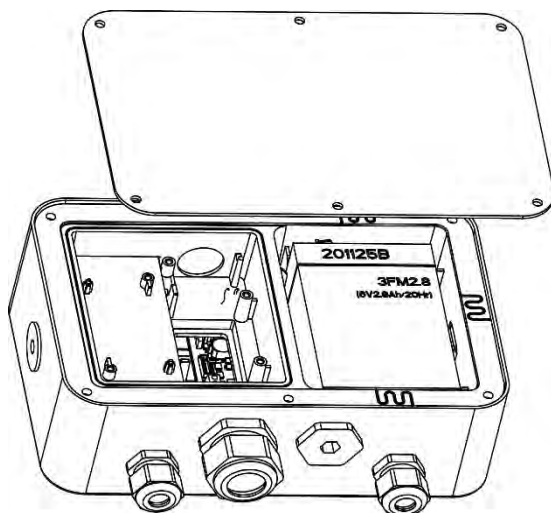

4. Close the housing and re-install the bolts after finishing internal connections

Note: The bolts should be tightened to 2.5 N•m (20-25 in-lb) torque to ensure a watertight seal.

2.3.2 EasyConnect™ Indicator

To connect an OHAUS EasyConnect™ scale base to an i-DT33P or an i-DT33XW EasyConnect™ indicator, plug the base's connector into the external load cell connector located at the back (i-DT33P) or bottom (i-DT33XW) of the indicator. Then rotate the base connector's locking ring in the direction of the arrows demonstrated below.

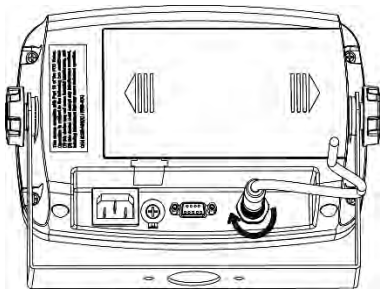

Figure 2-1 i-DT33P

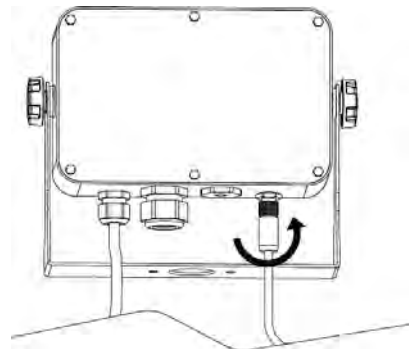

Figure 2-2 i-DT33XW

Note: For connecting bases which do not support EasyConnect™ to an EasyConnect™ indicator, contact an authorized OHAUS dealer to obtain a load cell cable gland kit (P/N 30379716) as an accessory.

2.3.3 Non-EasyConnect™ Indicator

To connect a non-EasyConnect™ scale base to an i-DT33P or an i-DT33XW non-EasyConnect™ indicator, follow the instruction in **Open the Housing** section to open the housing first before proceeding.

Note: For connecting EasyConnect™ bases to a non-EasyConnect™ indicator, contact an authorized OHAUS dealer to obtain a load cell cable gland kit (P/N 30427858) as an accessory.

2.3.3.1 i-DT33P

1. After opening the housing, release the load cell connector (circled) on the rear of the indicator and then pass the load cell cable through it.

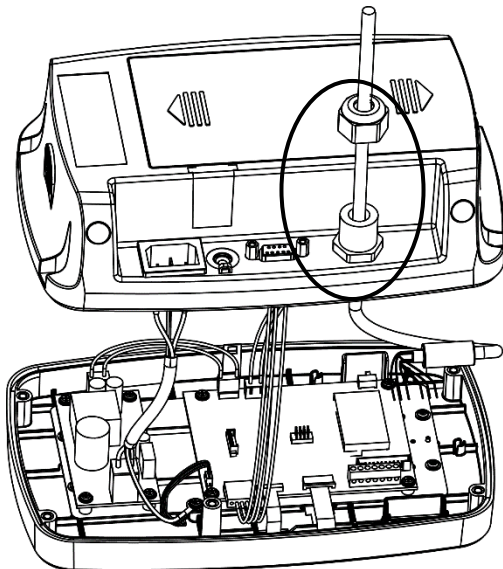

2. Connect all the cables on the load cell cable to the load cell terminal block on the mainboard (circled). Please refer to the **Load Cell Terminal Block** section for details of the connections.

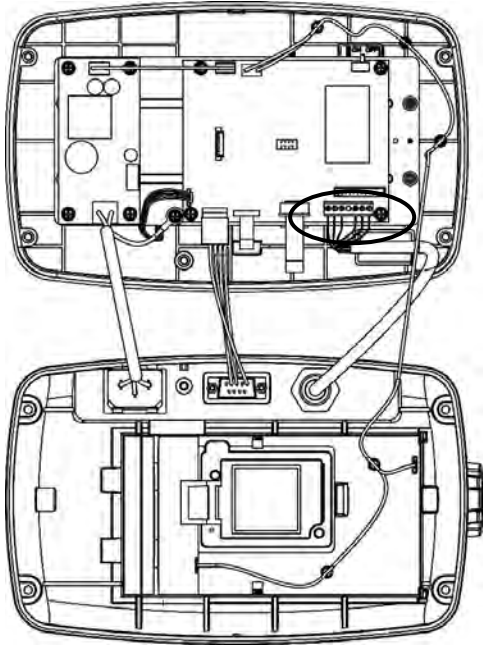

2.3.3.2 i-DT33XW

1. After opening the housing, unplug the battery connectors (circled) and take out the battery.

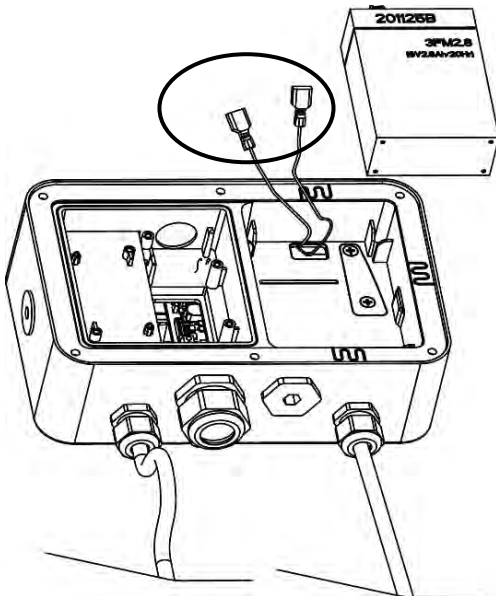

2. Unscrew the two screws on the sealing cover (circled), take out the cover, and then take out the first layer of the built-in housing.

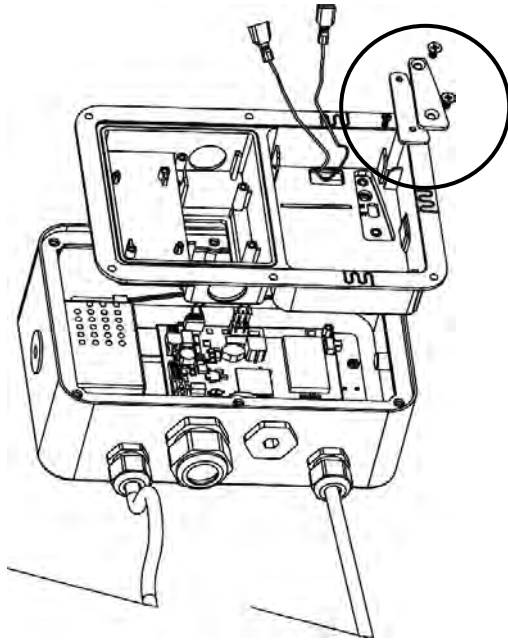

3. Release the load cell connector (circled) on the bottom of the indicator and then pass the load cell cable through it.

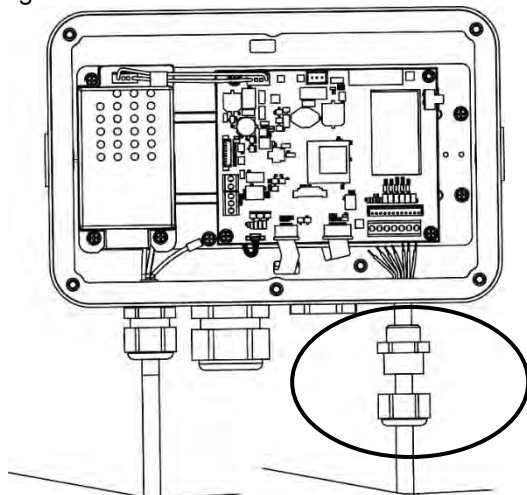

4. Connect all the cables on the load cell cable to the load cell terminal block on the mainboard (circled). Please refer to the **Load Cell Terminal Block** section for details of the connections.

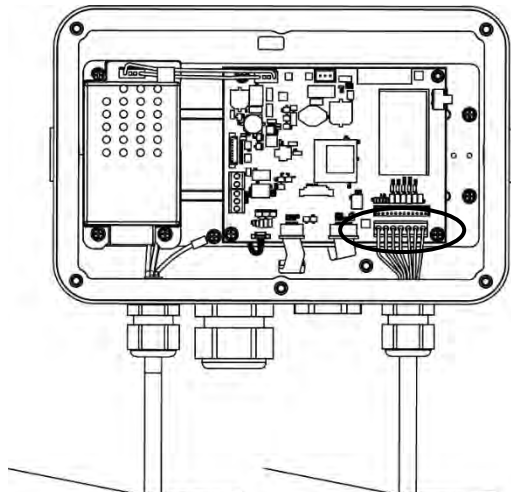

2.3.3.3 Load Cell Terminal Block

Proceed with the previous section, to connect the load cell terminal block, first locate it on the mainboard following the instruction in the previous two sections for the two models.

After finding the load cell terminal block, check table 2-1 for the definition of each terminal screw connection and make connections based on it. Please note that when using four-wire load cells, jumper connector (supplied with indicator) must be installed.

The i-DT33P and i-DT33XW indicators are designed to support both 2mV/V and 3mV/V load cells from the same circuitry. A load cell output rating selection jumper is not required.

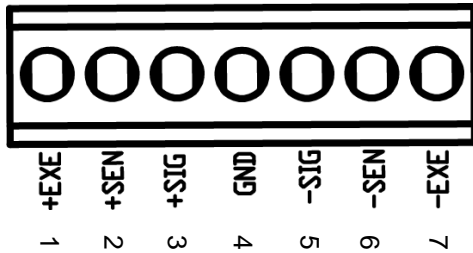

Figure 2-3 load Cell Terminal Block

Table 2-1 Jumper Connections

Number	Connection
1	+EXE
2	+SEN
3	+SIG
4	GND
5	-SIG
6	-SEN
7	-EXE

2.3.3.4 Installing the Ferrite Core

In order to meet certain electrical noise emission limits and to protect i-DT33P and i-DT33XW from external influences, it is necessary to install a ferrite core on the load cell cable connected to the indicator. The ferrite core is supplied.

To install it, simply route the cable through the center of the core. Either the complete cable or the individual wires can be wrapped through it.



Figure 2-4 Ferrite Core

2.3.4 i-DT33P RS232 Connection

Connect the optional RS232 cable to the RS232 connector on the rear housing of the i-DT33P indicator. Please refer to table 2-2 for the definition of each pin if needed.

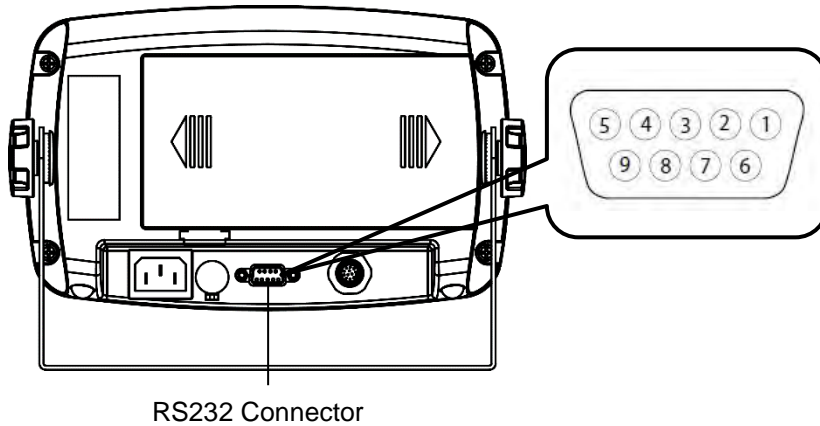

Table 2-2 RS232 Pins

Pin	Connection
1	N/C
2	TXD
3	RXD
4	N/C
5	GND
6	N/C
7	N/C
8	N/C
9	N/C

Figure 2-5 i-DT33P RS232 Connector

2.3.5 i-DT33XW RS232 Connection

For i-DT33XW model, to make the RS232 connection:

1. Open the rear housing. Please refer to **Open the Housing** section for how to open the rear housing.
2. Take out the battery. Please refer to the **i-DT33XW** sub-section of **Non-EasyConnect™ Indicator** section for how to take out the battery.
3. Release the strain relief for option connector on the bottom of the indicator and remove the plug on it.
4. Pass the optional RS232 cable through the connector and attach it to the RS232 terminal block on the mainboard.
5. Attach the watertight seal to the cable and push it into the strain relief for option connector. Tighten the strain relief for option connector with the watertight seal in it to finish installation.

Note: Please check the graphic below for the parts mentioned above.

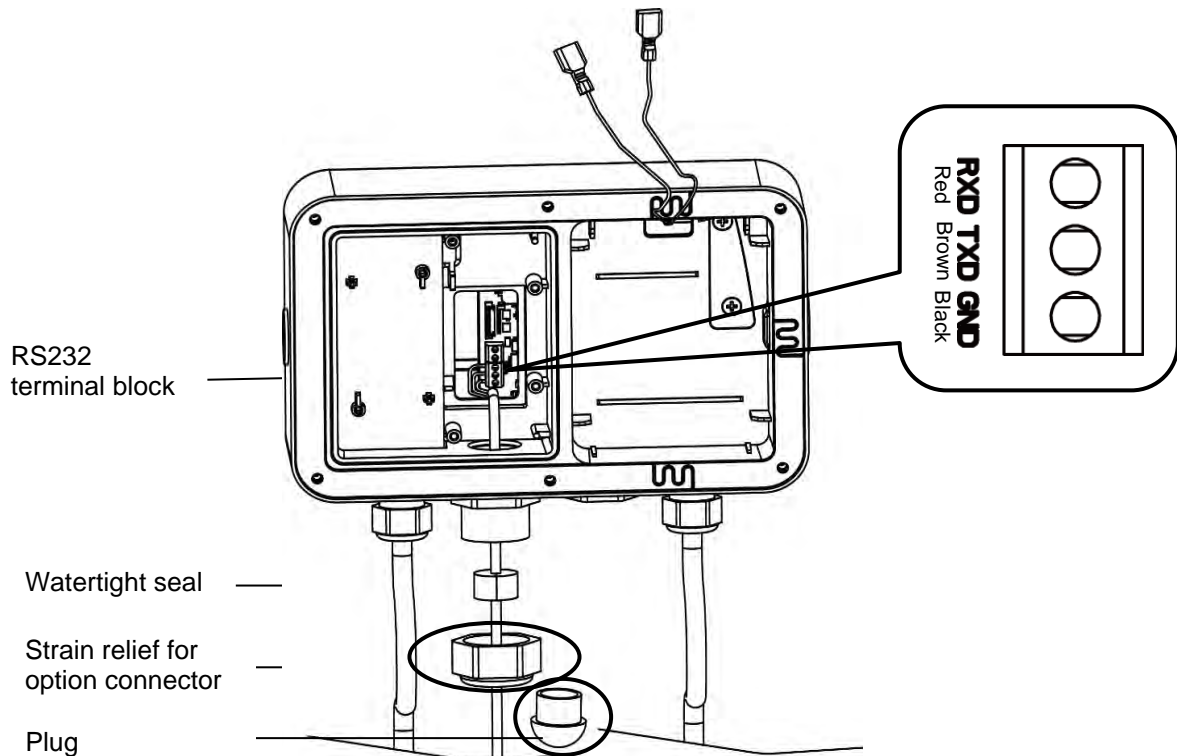

Figure 2-6 i-DT33XW RS232 Connection

2.4 Mounting Bracket

Attach the bracket to a wall or table using fasteners (not supplied) that are appropriate for the type of mounting surface. The bracket will accommodate up to 6 mm (1/4") diameter screws. Locate the mounting holes as shown in Figure 2-7 and 2-8.

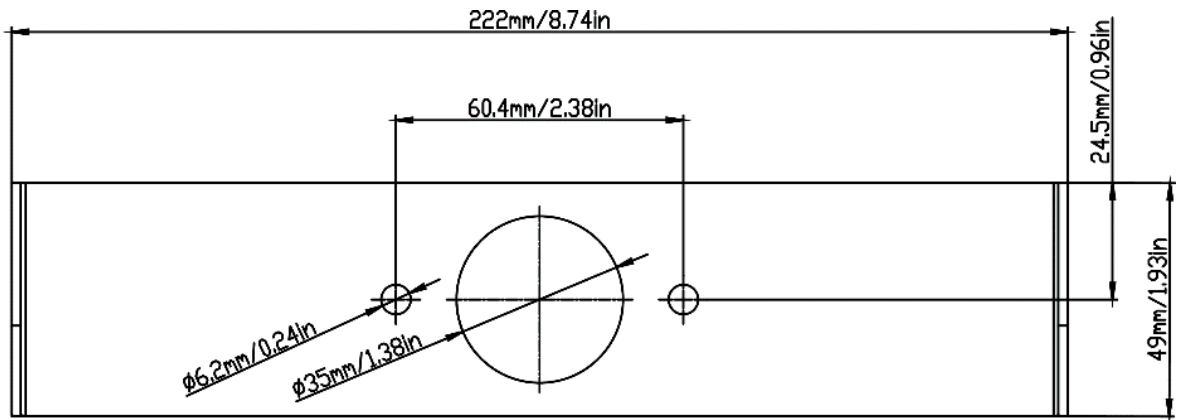

Figure 2-7 i-DT33P Mounting Bracket Dimensions

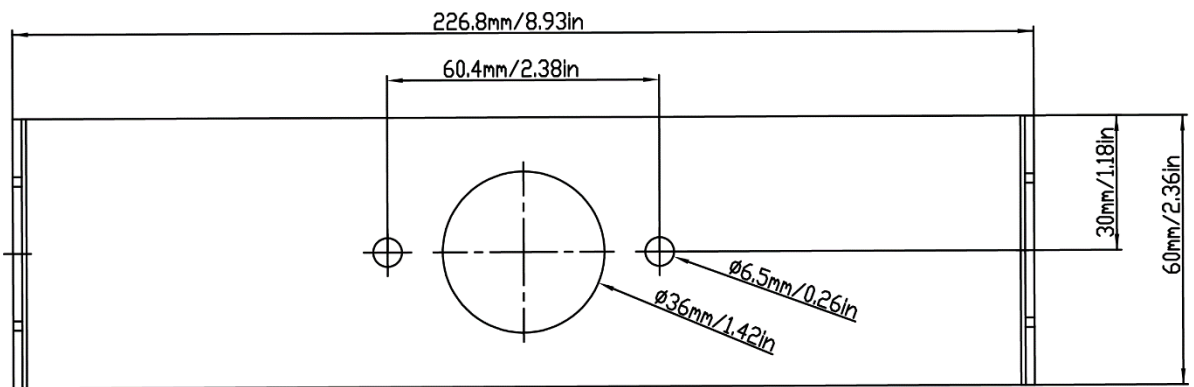

Figure 2-8 i-DT33XW Mounting Bracket Dimensions

3. OPERATION

3.1 Turning the Scale On/Off

To turn the scale on, short press the **On/Zero Off** button. The scale performs a display test, momentarily displays the software version, the GEO value and then enters the last active weighing mode.

Note: If the hardware lock switch is enabled, **LFE ON** will also be displayed briefly.

To turn the scale off, press and hold the **On/Zero Off** button until **OFF** is displayed.

3.2 Weighing Mode

Use this application to determine the weight of items in the selected unit of measure. This mode is the default factory setting.

3.2.1 Enter the Mode and Start Weighing

To enter the weighing mode:

1. Press and hold the **Mode** button until **LWE IGH** is displayed.
2. If needed, place an empty container on the pan and press the **Tare** button to tare.

Note: To check the tare weight:

- a) Long press the **Tare** button until **t.LWE** is displayed.
 - b) Release the **Tare** button and the tare weight will be displayed.
3. Add item to the pan or the container. The display shows the weight of the item.

3.2.2 Switch to GROSS or NET weight

In Weighing mode, and ONLY when there is a TARE weight in memory:

- Short press of the FUNCTION key can switch between GROSS and NET weight.

Note: Print will be blocked when the display shows GROSS weight.

3.2.3 Application Settings

The application can be customized for user preferences. To enter application settings:

1. Long press the **Menu** button until you see **FN.E.N.U.** Release the button and wait for the display to show **C.R.L.**
2. Short press the **No** button several times until you see **FN.O.d.E.** Press the **Yes** button to enter the application mode settings.
3. Short press the **No** button several times to navigate until you see the selection you want.
4. Press the **Yes** button to select.
5. Repeat step 3 and 4 several times until you finish all settings.
6. Press the **Exit** button to exit.

The Weighing configurations are defined below (defaults in Bold).

Item	Available Settings	Comments
Weighing (LWE IGH)	On , Off	To enable or disable Weighing

Note: You cannot disable Weighing if you are in the mode currently.

3.3 Counting Mode

Use this application to count the number of pieces on the pan based on an Average Piece Weight (APW).

3.3.1 Enter the Mode

1. Press and hold the **Mode** button until **Count** is displayed.
2. When the **Mode** button is released, the display shows **CLr.PWJ**.
 - If you need to clear the stored Average Piece Weight (APW) of the last time, press the **Yes** button, and then continue to the next step.
 - If you need to recall the stored APW of the last time and continue to use it, press the **No** button to start counting.

Note: If the display shows **CLr.PAN**, remove the weight on the pan or press the **Tare** button to tare.
3. The display shows the sample size **Pwt. 10**. To change it, short press the **No** button several times until you see the value you want.

Note:

 - Available sample size selections are 5, 10, 20, 50 and 100 (The default is 10).
 - When Legal for Trade is turned on, sample size selection 5 will not be available.
4. Place the specified quantity of pieces on the pan and press the **Yes** button to capture the current stable weight.

Note:

- Make sure all pieces in the sample are the same. Different pieces and weights will result in an inaccurate piece count.
- During the capture process, the display shows - - - - -.
- If the APW is between 0.1d and 1d, the display will show **LD.rEF** for 1.5 seconds. After that the scale will start counting.
- If the APW is less than 0.1d, the display will show **rEF.Err** for 1.5 seconds. After that it will go back to step 3, showing the sample size. Please replace a heavier batch of samples and press the **Yes** button to re-establish an APW value or change to a scale with readability suitable for your samples.

3.3.2 Start Counting

1. Place parts on the pan and read the number. The number of pieces and the Pcs icon are displayed.
2. Short press the **Function** button to temporarily display the APW. **APWJ** is displayed for 1 second, and then the APW value is displayed for 1 second with the weighing unit.

3.3.3 Application Settings

The application can be customized for user preferences. Please refer to **Application Settings** section in **Weighing Mode** for details about how to enter application settings.

The Counting Configurations are defined below (defaults in Bold).

Item	Available Settings	Comments
Count (Count)	On , Off	To enable Counting

Note: You cannot disable Counting if you are in the mode currently.

3.4 Check

Use this application to compare the weight of items to a target weight range.

The display color will change according to the comparing result:

- Red indicates over the target weight range
- Green indicates within the target weight range.
- Yellow indicates under the target weight range.

3.4.1 Set Check Limits

3.4.1.1 Set Check Limits Manually

1. Press and hold the **Mode** button until **CHECK** is displayed.
2. When the **Mode** button is released, the display shows **CLr.CHr**.
 - If you want to use the stored under and over value of the last time, press the **No** button, and the scale enters check mode directly.
 - If you want to set new over and under values, press the **Yes** button and continue to the next step.
3. The display shows **Under**. Press the **Yes** button to edit the under value.
4. **000000** is flashing on the display with the unit you set.
5. To set a new under value:
 - a) Short press the **No** button several times until the desired number appears.

Note:

 - Press the **Back** button can decrease the digit.
 - If you need to set a negative value, press the **Back** button when the first digit is zero or press the **No** button when the first digit is nine.
 - b) Short press the **Yes** button to accept the number and move to the next digit.
 - c) Repeat the process until all the digits are correct.
 - d) Press the **Yes** button to accept the value. Then the display will show **Over**.

Note: Please refer to the **Button Navigation** section for details of setting digits.
6. Repeat step 3 to 5 to set the over value.
7. If the values you set are invalid, the display will show **--n0--** and go back to reset the Under and Over value.
If the values you set are valid, the scale will enter check mode.

Note: Short press the **Function** button can display the over and under value.

3.4.1.2 Set Check Limits Using Reference Weights

1. Press and hold the **Mode** button until **CHECK** is displayed.
2. When the **Mode** button is released, the display shows **CLr.CHr**.
 - If you want to use the stored under and over value of the last time, press the **No** button, and the scale enters check mode directly.
 - If you want to set new over and under values, press the **Yes** button and continue to the next step.
3. The display will show **Under**. Press the **Yes** button to edit the under value.
4. Place the reference weights onto the scale.
5. The weight will be displayed on the screen, then press **Yes** to continue.
 - To accept the value as the Under Limit Value, press the **Yes** button.
 - To modify the value, press the **No**, **Back**, or **Yes** button to modify the numbers starting from the first digit (refer to the Button Navigation section).

After all digits are set, press the **Yes** button to accept the value. Then the display will show **Over**.
6. Press the **Yes** button to start edit the Over Limit value.
7. Repeat step 4-5 to set the Over Limit value.
8. If the values you set are invalid, the display will show **--n0--** and go back to reset the Under and Over value.
If the values you set are valid, the scale will enter check mode.

Note: Short press the **Function** button can display the over and under value.

3.4.2 Positive Check

Positive check is used to determine when the material added to the scale is within the target weight range. In this case the under and over values must be positive values. (The over value must be greater than the under value.)

To start, add material to the scale pan until the display turns green.

3.4.3 Negative Check

Negative check is used to determine when the material removed from the scale is within the target weight range. In this case the under and over values are both negative values. The under value must be greater than the over value. (For example: the under value is -10; the over value is -15).

To start, place a package or bin of material on the scale and press the **Tare** button.

Remove a portion of the package or material until the display turns green.
To continue weighing multiple portions off the scale's pan, tare the scale between each portion.

3.4.4 Zero Check

Zero check is used when comparing subsequent samples to an initial reference sample. In this case, the under value must be zero or a negative value and the over value must be zero or a positive one.
Place the reference sample on the scale and press the **Tare** button.
Remove material from the scale pan until the display turns green.

3.4.5 Application Settings

The application can be customized for user preferences. Please refer to **Application Settings** section in Weighing Mode for details about how to enter application settings.

The Check configurations are defined below (defaults in Bold).

Item	Available Settings	Comments
Check (CHECK)	On , Off	To enable or disable Check

Note: You cannot disable Check if you are in the mode currently.

3.5 Totalization

Use this application to manually or automatically accumulate the multiple weights. Statistical data (the number of samples, the total weight, the average weight, the minimum weight, the maximum weight and the difference in weight) is stored in memory for review and printing.

3.5.1 Application Settings

There are three totalization options:

- Off (**OFF**): disable the totalization function.
Manual (ᠮᠠᠮᠠᠨᠤ): press the **Function** button to perform totalization manually.
 Auto (**ᠠᠤᠮᠤᠯᠤᠳᠤ**): the scale will perform totalization automatically.
Note: The default is manual.

To set the totalization option:

1. Long press the **Menu** button until you see **ᠮᠠᠮᠠᠨᠤ**. Release the button and wait for the display to show **ᠴᠠᠷᠠᠯ**.
2. Short press the **No** button several times to navigate until you see **ᠮᠠᠮᠠᠨᠤ**, press the **Yes** button.
3. Short press the **No** button several times to navigate until you see **ᠠᠤᠮᠤᠯᠤᠳᠤ**. Press the **Yes** button.
4. Short press the **No** button several times to navigate between different totalization options. The three options have been introduced above. Press the **Yes** button to confirm your selection.
5. Press the **Exit** button to exit.

3.5.2 Enter the Mode

1. Press and hold the **Mode** button until **ᠠᠤᠮᠤᠯᠤᠳᠤ** is displayed.
2. When the **Mode** button is released, the display shows **ᠴᠠᠷᠠᠴᠴ**.
 - If you need to clear the stored totalization result of the last time, press the **Yes** button, and then start totalization.
 - If you need to recall the stored totalization result of the last time, press the **No** button to continue the totalization of the last time.

Note: If there is weight on the pan, the display will show **ᠴᠠᠷᠠᠮᠠᠨ** until the weight is removed or you press the **Tare** button to tare.

3.5.3 Totalization Method

Manual

Place an item on the pan and press the **Function** button to add the weight to totalization.

Auto

Place an item on the pan. The displayed value is totalized automatically.

The flash of the Σ icon indicates the scale has totalized the weight successfully. It will keep flashing until the weight is removed and the pan is stable.

Notes:

- The item must be removed from the pan before the next item can be totalized.
- Only stable weights are stored.
- When Legal for Trade is turned ON, for NTEP models, gross and net weight cannot be added to the same total. If the first weight is recorded in gross, the future ones should be recorded in the same way. It is the same for the net weight.

3.5.4 View Totalization Result

When there is no weight on the pan, press the **Function** button to view the result.

The result includes the number of samples, the total weight, the average weight, the minimum weight, the maximum weight and the difference in weight (the maximum weight minus the minimum weight). The values are displayed for 1 second each.

3.5.5 Totalization Rules

The totalization operation will fail when:

1. The current weight is unstable.
2. The load's net weight is smaller than 5d.
3. The overall totalized number is larger than 999999. (The unit is according to what you set for the scale.)
4. The total number of totalization exceeds 9999 times.

3.5.6 Print Totalization Result and Format

● **During totalization, to print the current weight:**

1. Enable the Table on (**TABLE**) option in the menu.
To do this:
 - a) Long press the **Menu** button until you see **TABLE**. Release the button and wait for the display to show **TABLE**.
 - b) Short press the **No** button several times to navigate until you see **TABLE**. Press the **Yes** button.
 - c) Short press the **No** button several times to navigate until you see **TABLE**. Press the **Yes** button.
 - d) Short press the **No** button until you see **ON** flashing on the screen. Press the **Yes** button to enable.
 - e) Press the **Exit** button to exit.
2. After the Table on option is enabled:
 - In automatic totalization mode, the scale will automatically print the current weight when it is totalized successfully.
 - In manual totalization mode, press the **Function** button to totalize the current weight and print it accordingly.

The print output for current weight will appear as the example below:

Example:

1.	1000 g G
2.	2000 g G
3.	3000 g G
4.	1999 g G
5.	1000 g G

● **When totalization is finished, to print the totalization result:**

1. Press the **Function** button with no weight on the pan to show the totalization result.
2. Press the **Print** button to print the result while the totalization result is displayed on the screen.

Note: if you do not press the **Function** button to display the totalization result, the scale will print the print template you set.

When totalization is finished, the print output for Totalization result will appear as the example below:

Example:

n:	5
Total:	8999 g
Avg:	1800 g
Min:	1000 g
Max:	3000 g
Diff:	2000 g

Note: The scale supports 32 characters and the left and right content will be aligned.

3.5.7 Application Settings

The application can be customized for user preferences. Please refer to **Application Settings** section in **Weighing Mode** for details about how to enter application settings.

The Totalization Configurations are defined below (defaults in Bold).

Item	Available Settings	Comments
Totalization (TOTAL)	Off, Auto, Manual	To select Totalization method or disable it

Note: you cannot disable Totalization if you are in the mode currently.

The Table Configurations are defined below (defaults in Bold).

Item	Available Settings	Comments
Table (TABLE)	On, Off	To enable or disable Table for printing current weight during Totalization

3.6 Skip

There are two options:

- Off (OFF) The skip function is disabled (Default)
- On (ON) The skip function is enabled, it affects the following application modes: The Counting function skips **CLR.PWJ**, the Check function skips the **CLR.CHT**, the Totalization function skips the **CLR.ACC**.

To set the skip option:

1. Long press the Menu button until you see **T.E.N.U.**
2. Release the button and wait for the display to show **C.R.L.**
3. Short press the No button several times to navigate until you see **T.O.d.E**, press the Yes button to enter the sub menu.
4. Short press the No button several times to navigate until you see **S.T. 1.P**
 - a) If you want to turn on the skip function, select **ON**, then short press the Yes button to confirm.
 - b) If you want to turn off the skip function, short press the No button several times until you see **OFF**, then short press the Yes button to confirm.
5. Press the Exit button to exit.

4. MENU SETTINGS

The User Menu allows the customizing of scale settings.

Note: Sub-menu for options (USB, Ethernet and Print2 in the table below) will be active only when the specific board is installed. See their separate option instruction manuals for additional setting information.

4.1 Menu Navigation

4.1.1 User Menu (in segments)

C.A.L	S.E.t.U.P	r.E.A.d	m.O.d.E	U.n. It	A.S.2.3.2	P.r. I.N.t	U.S.b	E.t.H.N.E.t	P.r. I.N.t2	L.o.c.t	E.n.d
ZErD	rESEt	rESEt	rESEt	rESEt	rESEt	rESEt	rESEt	rESEt	rESEt	rESEt	rESEt
SPAN	C.UN It	StAbLE	WJE IGH	kg	bAUd	ASS IGH	bAUd	IP.Addr	ASS IGH	L.ALL	
L INE	rANGE	ZErD	COUNt	g	PAR ItY	StAbLE	PAR ItY	u.E.r.	StAbLE	L.OFF	
GEO	CAP1	F ILtEr	CHECt	lb	StOP	mOde	StOP	ENd	mOde	L.ZErD	
C.tESEt	GrAd1	A2t	tOEtAL	oz	H.SHARtE	t INtE	H.SHARtE		t INtE	L.Pr INt	
End	CAP2	b.L IGHt	tAbLE	lb:oz	ALt.P	L INtEo	ALt.P		L INtEo	L.UN It	
	GrAd2	b.COLOr	End	t	ALt.t	C.SUPP	ALt.t		C.SUPP	L.mOde	
	P.ZErD	C.COLOr		End	ALt.2	tEPPP	ALt.2		tEPPP	L.mENU	
	P.UN It	SCrEEN			End	End	End		ENd	L.tArE	
	A.tArE	A.OFF								End	
	End	P.SAUEr									
		CEC									
		End									

Notes:

Some modes/units may not be available in all models.

When LEGAL FOR TRADE is turned **ON** (the security switch S1 is in the locked position), the menu settings will be affected as below:

- Calibration function is disabled.
- Zero Range setting is locked at 2%.
- Stable Range setting is locked at 1d.
- Auto-Zero Tracking setting is locked at 0.5d.
- Filter and Units are locked at their current settings.
- Stable Only is locked at On.
- Lb:oz unit is locked at Off.
- Power saving mode is disabled.

Note: Please refer to **Legal for Trade** chapter for the position of the security switch S1.

4.1.2 Button Navigation

- The **Yes** button: allows entry into the displayed menu.
Accepts the displayed setting and advances to the next item.
- The **No** button: rejects entry into the displayed menu.
Rejects the displayed menu and moves on to the next selection.
- The **Back** button: moves backwards to the previous menu.
Returns to the previous displayed menu or selection.
- The **Exit** button: exits from user menu to the active weighing mode.

For menu items which need to set numbers such as the scale capacity, the current number is displayed with all digits flashing. To revise:

1. Press the **No** button to begin editing.

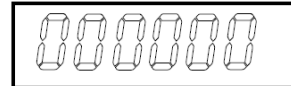

2. The first digit is displayed flashing.



3. Press the **No** button to increase the digit or press the **Yes** button to accept the digit and move to the next one.



Note: press the **Back** button can decrease the digit.

4. Repeat this process for all digits.



5. Press the **Yes** button when the last digit has been set.



6. The new setting is displayed with all digits flashing. Press the **Yes** button to accept the setting or press the **No** button to resume editing.

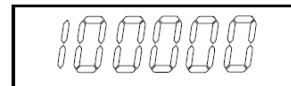

7. To end the current menu selection, press the **Yes** button to advance to the next menu, or press the **No** button to return to the top of the current menu.

4.2 Calibration Menu

Enter the calibration menu **C.A.L** to perform calibrations.

4.2.1 Initial Calibration

When the scale is operated for the first time, a zero and span calibration are recommended to ensure accurate weighing results.

Before performing the calibration, be sure to have the appropriate calibration weights as listed in table 4-1. Ensure that the LFT switch/calibration lock is set to the unlocked position.

You can also adjust the GEO setting according to your location. For detailed GEO information, please check the **Geo Code Adjustment** section below.

Table 4-1 Suggested Span Calibration Mass (Sold Separately)

Max Capacity (kg)	Mass* (kg)	Max Capacity (lb)	Mass* (lb)
3 kg	3 kg	6 lb	6 lb
6 kg	6 kg	12 lb	12 lb
15 kg	15 kg	30 lb	30 lb
30 kg	30 kg	60 lb	60 lb
60 kg	60 kg	120 lb	120 lb
150 kg	150 kg	300 lb	300 lb

Note: The calibration unit is consistent with the capacity unit.

4.2.2 Zero Calibration [ZEr0]

Zero calibration uses one calibration point. The zero calibration point is established with no weight on the scale. Use this calibration method to adjust for a different static load without affecting the span or linearity calibration.

Calibration procedures:

1. Long press the **Menu** button until you see **0.0.0.0**.
2. Release the button and wait for the display to show **C.A.L**. Press the **Yes** button.
3. The display shows **ZEr0**. Press the **Yes** button.
4. **0** kg and the calibration unit are flashing on the display. With no weight on the pan, press the **Yes** button to establish the zero point.
5. The display shows **--C--**, and then **-dONE-** when the Zero calibration is finished.

Note:

If zero calibration is failed or if after 40 seconds the calibration is still not successful, **CAL E** is displayed for 3 seconds and the previous calibration data will be restored.

6. Then the display shows **SPAN**. Press the **Exit** button to exit.

4.2.3 Span Calibration [SPAN]

Span calibration uses one calibration point. It is established with a calibration mass placed on the scale.

Note: Span calibration should be performed after zero calibration.

Calibration procedures:

1. Long press the **Menu** button until you see **0.0.0.0**.
2. Release the button and wait for the display to show **C.A.L**. Press the **Yes** button.
3. Short press the **No** button to navigate until you see **SPAN**. Press the **Yes** button.
4. The calibration point and the unit are flashing on the display based on the scale capacity and unit set in the menu. (e.g. **030.000** kg) If you do not need to change the calibration point, skip to step 6.
5. To change the calibration point:
 - a) Short press the **No** button several times until the desired number appears.
Note: press the **Back** button can decrease the digit.
 - b) Short press the **Yes** button to accept the number and move on to the next digit.

- c) Repeat the process until all the digits are correct.
- d) Press the **Yes** button to accept calibration point. It is flashing on the display.
6. Place a calibration mass of the specified weight on the pan and press the **Yes** button.
7. The display shows **--[--**, and then **-DONE-** when the calibration is finished.
8. Then the display shows **L 0**. Press the **Exit** button to exit.

Note:

- If calibration is failed, **CAL E** is displayed for 3 seconds and the previous calibration data is restored.
- If after waiting for 40 seconds the calibration is still not successful, **CAL E** is displayed for 3 seconds and the previous calibration data is restored.

4.2.4 Linearity Calibration [L 0]

Linearity calibration uses 3 calibration points. The full calibration point is established with a weight on the pan. The mid calibration point is established with a weight equal to half of the full calibration weight on the pan. The zero calibration point is established with no weight on the pan. The full calibration and mid calibration points can be altered by users during the calibration procedure.

Calibration procedures:

1. Long press the **Menu** button until you see **00.E.0.0**.
2. Release the button and wait for the display to show **C.A.L.** Press the **Yes** button.
3. Short press the **No** button several times to navigate until you see **L 0**. Press the **Yes** button.
4. **0** kg and the calibration unit are flashing on the display. With no weight on the pan, press the **Yes** button to establish the zero point. The display shows **--[--**.
5. Then the first calibration point and the unit are flashing on the display based on the scale capacity and unit you set in the setup menu. (For example, **0 15.000** kg). If you do not need to change the calibration point, skip to step 7.
6. To change the calibration point:
 - a) Short press the **No** button several times until the desired number appears.
Note: press the **Back** button can decrease the digit.
 - b) Short press the **Yes** button to accept the number and move on to the next digit.
 - c) Repeat the process until all the digits are correct.
 - d) Press the **Yes** button to accept calibration point. It is flashing on the display.
7. Place a calibration mass of the specified weight on the pan and press the **Yes** button. The display shows **--[--**.
8. The second calibration point and the unit are flashing on the display based on the capacity and unit you set in the setup menu. (For example, **030.000** kg)

Note:

If after waiting for 40s the calibration is still not successful, **CAL E** is displayed for 3 seconds and the previous calibration data is restored.

9. Repeat step 6 and 7.
10. The display shows **--[--**, and then **-DONE-** when the Linearity calibration is finished.
11. After that the display shows **GEO**. Press the **Exit** button to exit.

4.2.5 GEO Code Adjustment [GEO]

Geographical Adjustment Factor (GEO) code is used to adjust the calibration based on the current location. Settings from 0 to 31 are available with 12 being the default.

Please refer to the **Table of Geo Code Values** section in the **Technical Data** chapter to determine the GEO factor that corresponds to the indicator's location.

To set the GEO factor:

1. Long press the **Menu** button until you see **00.E.0.0**.
2. Release the button and wait for the display to show **C.A.L.** Press the **Yes** button.
3. Short press the **No** button several times to navigate until you see **GEO**. Press the **Yes** button.
4. The Geo point is flashing on the display (For example, **12**).

5. Short press the **No** button several times until the desired GEO number appears. Press the **Yes** button to accept.
Note: Press the **Back** button can decrease the digit.
6. Then the display shows **[C.tESEt]**. Press the **Exit** button to exit.

4.2.6 Calibration Test [C.tESEt]

Calibration test procedures:

1. Long press the **Menu** button until you see **00.E.R.U.**
2. Release the button and wait for the display to show **C.R.L.** Press the **Yes** button.
3. Short press the **No** button several times to navigate until you see **[C.tESEt]**. Press the **Yes** button.
4. **0** and the calibration unit are flashing on the display based on the capacity and unit you set in the setup menu. With no weight on the pan, press the **Yes** button to establish the zero point.
5. The display shows **--[C]--** while the zero point is recorded.
6. The calibration weight and the unit of the last time are flashing on the display. (For example, **0 15.000** kg).
6. To change the test calibration weight:
 - a) Short press the **No** button several times until the desired number appears.
Note: press the **Back** button can decrease the digit.
 - b) Short press the **Yes** button to accept the number and move on to the next digit.
 - c) Repeat the process until all the digits are correct.
 - d) Press the **Yes** button to accept the calibration point. It is flashing on the display.
7. Place the specified test weight on the pan and press the **Yes** button.
8. The difference between the calibration data and the test weight is flashing on the display. (For example, **0.0 10** kg). If the indicator is connected to a printer or other devices, the result will be printed.
Note: the printed result will appear as below:
Example:

```

----- Cal Test -----
New Cal:6.0000kg
Old Cal:6.0000kg
Diff Cal:0.0000kg
Wt. ID:_____
----- End -----

```
9. After 5 seconds, the test ends and the scale returns to the active weighing mode, displaying the current weight.

4.2.7 End Cal [End]

When **End** is displayed, press the **Yes** button to exit this menu and advance to the next sub-menu, or press the **No** button to advance to the first menu item in the this sub-menu.

4.3 Setup Menu

Enter this menu **5.E.t.u.P** to set scale parameters. Default settings are in **bold**.

Menu	Sub-Menu	Sub-Menu (in segment)	Options	Options (in segment)
Setup 5.E.t.u.P	Reset	rESEt	no, yes	NO, YES
	Capacity Unit	C.uN tE	kg, lb	/
	Range	rRNGE	Single , Dual	S INGLE, dUAl
	> 1 < Capacity	CRP	0.1-99999.9	/
	> 1 < Graduation	GrAd	0.0001~100	/
	> 2 < Capacity	CRP	0.1-99999.9	/
	> 2 < Graduation	GrAd	0.0001~100	/
	Power On Zero	P.ZEr0	Off, On	OFF, ON
	Power On Unit	P.uN tE	Auto , g, kg, lb, oz, lb:oz, t	AUTO
	Auto Tare	R.tARtE	Off , On, Accept	OFF, ON, ACCEPt
	End	End	/	/

Note: / refers to not applicable in the table above.

Reset [rESEt]

Reset the Setup menu to factory defaults.

NO = do not reset
YES = reset

Capacity Unit [C.uN tE]

Select the unit used for calibration.

kg
lb

Range [rRNGE]

Selects the number of weighing intervals.

This terminals can be configured to use single or dual interval. Each interval can be assigned its own graduation. If dual interval is selected, the graduation will change when the weight reaches the second interval.

When **Single** interval is selected, the additional parameters available are:

- Capacity
- Graduation

When **Dual** interval is selected, the terminal functions with two intervals, each with its own capacity and graduation. In addition to the Interval 1 capacity and graduation parameters, the following two parameters are available:

Capacity 2
Graduation 2

Capacity [CRP] / Capacity1 [CRP 1]

Set the capacity of the scale or the first capacity of the scale.
0.1-99999.9

Grad [GrAd] / Grad1 [GrAd 1]

Set the scale readability or the first readability of the scale.
0.0001~100

Capacity2 [CRP2]

Set the second capacity of the scale.

Grad2 [G-RAD2]

Set the second readability of the scale.

Note:

- The value of graduation 2 must be larger than graduation 1, and it applies to capacity as well.
- The capacity and graduation value should be within the following range, or your setting will be unsuccessful:

$$\text{Capacity} / 30000 \leq \text{Graduation} \leq \text{Capacity} / 600$$

Power On Zero [P.ZE-0]

Zero the scale at Power On.

OFF = disabled.

ON = enabled.

Power On Unit [P.ON U]

Set the unit that will be displayed at Power On.

AUTO = last unit in use when turned off

kg = kilograms

g = grams

lb = pounds

oz = ounces

lb:oz = pound ounces

t = metric tonne

Auto Tare [A.TAR-E]

Set the automatic tare feature.

OFF = automatic tare is disabled.

ON = the first stable gross weight is tared. The tared value will be cleared when the indicator returns to gross zero.

ACCEPT = stable gross weights within the Accept limits are tared (in Check mode only).

4.4 Readout Menu

Enter this menu to set user preferences. Default settings are in **bold**.

Menu	Sub-Menu	Sub-Menu (in segment)	Options	Options (in segment)
Read Out (r.E.R.d)	Reset	rESEt	no, yes	NO , YES
	Stability	StAbLE	0.5d, 1d , 2d, 5d	0.5d , 1d , 2d, 5d
	Zero Range	ZErO	2%, 100%	2 , 100
	Filter Level	F ILtEr	Low, Medium , High	LOW , MEd , HIGH
	Auto Zero Track	AZt	Off, 0.5d , 1d, 3d	OFF , 0.5d , 1d, 3d
	Back Light	b.L IGht	Off, On, Auto	OFF , ON , AUtO
	Back Light Color	b.COLOr	Green, Yellow, Red, Amber	GrEEn , rEd , YELLoW , AmBER
	Check Light Color	C.COLOr	Red-Green-Yellow Yellow-Green-Red	r-g-y y-g-r
	Screen Saver	ScREEN	Off, 1min , 2min, 5min	OFF , 1 , 2 , 5
	Auto Off	A.OFF	Off , 1min, 5min, 10min	OFF , 1 , 5 , 10
	PWM.SAVE	P.SAVEr	ON , OFF	ON , OFF
	CEC	CEC	ON, OFF	ON , OFF
	End	End	/	/

Note: / refers to not applicable in the table above.

Reset [rESEt]

Reset the readout menu to factory defaults.

- NO** = do not reset.
- YES** = reset

Stability [StAbLE]

Set the amount reading can vary before the stability symbol turns off.

- 0.5d** = 0.5 of a scale division
- 1d** = 1 scale division
- 2d** = 2 scale divisions
- 5d** = 5 scale divisions

Zero [ZErO]

Set the percentage of scale capacity that can be zeroed.

- 2%** = zero range is within +/-2%
- 100%** = zero range is within +/-100%

Filter [F ILtEr]

Set the amount of signal filtering.

- LOW** = faster stabilization time with less stability.
- MEd** = normal stabilization time with normal stability.
- HIGH** = slower stabilization time with more stability.

AZT [AZt]

Set the automatic zero tracking feature.

- OFF** = disabled
- 0.5d** = the display will maintain zero until a change of 0.5 of a divisions per second has been exceeded.
- 1d** = the display will maintain zero until a change of 1 division per second has been exceeded.
- 3d** = the display will maintain zero until a change of 3 divisions per second has been exceeded.

Backlight [b.LIGHT]

Set the display backlight feature.

- OFF** = backlight is disabled.
- ON** = backlight is enabled and always on.
- AUTO** = backlight is disabled after 20 seconds of no activity.

Backlight Color [b.COLOR]

Set the display backlight color.

- AMBER** = backlight color is amber.
- GREEN** = backlight color is green.
- RED** = backlight color is red.
- YELLOW** = backlight color is yellow.

Check Light Color [C.COLOR]

Set the format of check light color.

- r-G-Y** = Red: Under limit
Green: Within the limit range
Yellow: Over limit
- Y-G-r** = Yellow: Under limit
Green: Within the limit range
Red: Over limit

Screen Saver [SSCREEN]

Set whether the screen saver is enabled after the selected time period.

- OFF** = screen saver is disabled
- 1** = the screen saver is enabled after 1 minute of no activity.
- 2** = the screen saver is enabled after 2 minutes of no activity.
- 5** = the screen saver is enabled after 5 minutes of no activity.

Auto Off [A.OFF]

Set whether the display enters sleep mode after the selected time period.

- OFF** = disabled
- 1** = the display enters sleep mode after 1 minute of no activity.
- 5** = the display enters sleep mode after 5 minutes of no activity.
- 10** = the display enters sleep mode after 10 minutes of no activity.

PWM.SAVE [P.SAVE]

Set whether to enable power saving mode after the scale enters standby mode. If it is enabled, it will take about 3 seconds before the indicator returns to weighing when weight is changed on the pan or you press the indicator's buttons.

- ON** = power saving is enabled.
- OFF** = power saving is disabled.

CEC [CEC]

Set whether to enable California Energy Commission function. When enabled, the energy plan complies with the California Energy Commission regulation.

- ON** = CEC is enabled.
- OFF** = CEC is disabled.

End Readout [End]

Advance to the next menu or return to the top of the current menu.

4.5 Unit Menu

Enter this menu **U.N. 1.t** to activate the desired units.

Reset
 Gram (g)
 Kilogram (kg)
 Pound (lb)
 Ounce (oz)
 Pound:Ounce (lb:oz)
 Metric Tonne (t)
 End

Note:

- Available units vary by model. In addition, due to national laws, the indicator may not include some of the units listed.
- If the security switch is turned on, the Units menu will be locked at their current setting.
- When the scale capacity is set to be more than 1000 kg, **Metric Tonne (t)** unit will appear in the Unit menu.

4.6 Communication

Enter this menu to define external communication methods and to set printing parameters. Data may be output to either a printer or PC. Factory default settings are shown in bold.

4.6.1 RS232 Menu

Enter this menu to define communication parameters.

Menu	Sub-Menu	Sub-Menu (in segment)	Options	Options (in segment)
RS232 (r.5.2.3.2)	Baud Rate	bAUD	300, 600, 1200, 2400, 4800, 9600 , 19200, 38400, 57600	/
	Parity	PAR 1.t	7 Even, 7 Odd, 7 None, 8 None	7 Even , 7 Odd , 7 None , 8 None
	Stop Bit	STOP	1 bit , 2 bit	1 bit , 2 bit
	Handshake	H.SHAKE	None , Xon/Xoff	None , ON-OFF
	Alt Print CMD	ALT.P	'A' ~ 'Z', P	/
	Alt Tare CMD	ALT.t	'A' ~ 'Z', T	/
	Alt Zero CMD	ALT.z	'A' ~ 'Z', Z	/
	Reset	rESEt	no , yes	no , YES
End	End	/	/	

Note: / refers to not applicable in the table above.

Reset [**rESEt**]

Reset the RS232 menu to factory defaults.

no = do not reset.
YES = reset

Baud Rate [**bAUD**]

Set the baud rate (bits per second).

300 = 300 bps
 600 = 600 bps
 1200 = 1200 bps
 2400 = 2400 bps
 4800 = 4800 bps
9600 = 9600 bps
 19200 = 19200 bps
 38400 = 38400 bps
 57600 = 57600 bps

Parity [PARITY]

Set the data bits and parity.

- 7 EVEN = 7 data bits, even parity
- 7 ODD = 7 data bits, odd parity
- 7 NONE = 7 data bits, no parity
- 8 NONE = 8 data bits, no parity

Stop bit [STOP]

Set the number of stop bits.

- 1 bit = 1 stop bits
- 2 bit = 2 stop bits

Handshake [HANDSHAKE]

Set the flow control method. Hardware handshaking is only available for COM1 menu.

- NONE = no handshaking
- ON-OFF = XON/XOFF software handshaking

Alternate Print command [ALT.P]

Set the alternate command character for Print.

Settings of A (a) to Z (z) are available. The default setting is P.

Alternate Tare command [ALT.T]

Set the alternate command character for Tare.

Settings of A(a) to Z(z) are available. The default setting is T.

Alternate Zero command [ALT.Z]

Set the alternate command character for Zero.

Settings of A (a) to Z (z) are available. The default setting is Z.

End [End]

Advance to the next menu or return to the top of the current menu.

4.6.2 Print Menu

Enter this menu to set printing parameters. Default settings are **bold**.

Menu	Sub-Menu	Sub-Menu (in segment)	Options	Options (in segment)
Print (P.r. i.n.t. i)/	Assignment	ASSIGN	Demand , Auto On Stable, Auto On Accept, Interval(seconds), MT-Continuous, OH-Continuous, SICS	DEMAND , ON.StAb, ON.ACCEP, IntEr, PnL.CO, OH.CO, SICS
	Stable Weight Only [Demand]	StAbLE	Off , On(LFT Force On)	OFF , ON
	Mode [Auto On Stable]	MOdE	Load , Load and Zero	LOAD , LOAD-Zr
	Time [Interval (seconds)]	TIvE	1~5000	/
	Checksum [MT-Continuous]	CSUM	On, Off	ON, OFF
	Link to [OH-Continuous]	LINK	Off , Custom 1, Custom 2	OFF . CUS1, CUS2
	Template	TEMP	Custom 1 , Custom 2	CUS1 , CUS2
	Reset	RESEt	no , yes	NO, YES
	End	End	/	/

Note: / refers to not applicable in the table above.

Reset [RESEt]

Reset the Print menu to factory defaults.

- NO = do not reset.
- YES = reset

Assignment [ASSIGN]

Demand [DEMAND]

If **Demand** is selected, the sub-menu **Stable Only** will display.

Set the printing criteria.

- OFF** = values are printed immediately, regardless of stability.
- ON = values are printed only when the stability criteria is met.

Auto On Stable [ON.StAb]

If **Auto On Stable** is selected, the sub-menu **Mode** will display.

Set the printing mode.

- LOAD** = prints when the displayed load is stable.
- LOAD-Zr = prints when the displayed load and zero reading are stable.

Auto On Accept [ON.ACCEP]

If **Auto On Accept** is selected and the weighing mode is **Check**, values will be printed when the weight is accepted.

- ON.ACCEP = printing occurs each time the display is within the Accept range and stability criteria is met.

Interval [IntEr]

If **Interval** is selected, the sub-menu **Time** will display.

- IntEr = printing occurs at the defined time interval. Settings of 1 to 5000 seconds are available. Default is 1. Printing occurs at the defined time interval.

MT-Continuous [ጠግኔ.ርግግ]

If **MT-Continuous** is selected, the print output will be in the **MT-Continuous** format.

ጠግኔ.ርግግ = printing occurs continuously.

Note: Refer to Appendix A for **MT-Continuous** format.

ፈ.5ህጥግ

Off = disabled

On = enabled

OH-Continuous [ዐዛ.ርግግ]

If **OH-Continuous** is selected, the print output will be in the **OH-Continuous** format.

Note: Refer to Appendix D for **OH-Continuous** format.

ዐዛ.ርግግ = printing occurs continuously.

ፈ.ገጠፋፈፈ

OFF = disabled

ፈህ5ኔ 1 = print using custom 1 template.

ፈህ5ኔ 2 = print using custom 2 template.

SICS [5 ሳር5]

ፈFF = disable MT-SICS command

ፈግ = enable MT-SICS command

Note: Refer to Appendix B for **SICS** commands.

End Print [ፎጠፈ]

Advance to the next menu or return to the top of the current menu.

Template [ፎፎጥጥፆ]

This sub-menu is used to define the format of the data output to a printer or computer.

ፈህ5ኔ 1 = customized printout format.

ፈህ5ኔ 2 = customized printout format.

Print template example :

0.000 kg

0.300 kg G

0.000 kg N

0.100 kg T

Connect the indicator to OHAUS ScaleMate software on a PC via the RS232 (or USB or Ethernet optional ports). To customize print template, you need to go to the ScaleMate software, Select **Print Template** on the top bar, and then double click items in the left column to select which ones you want to put in your print template.

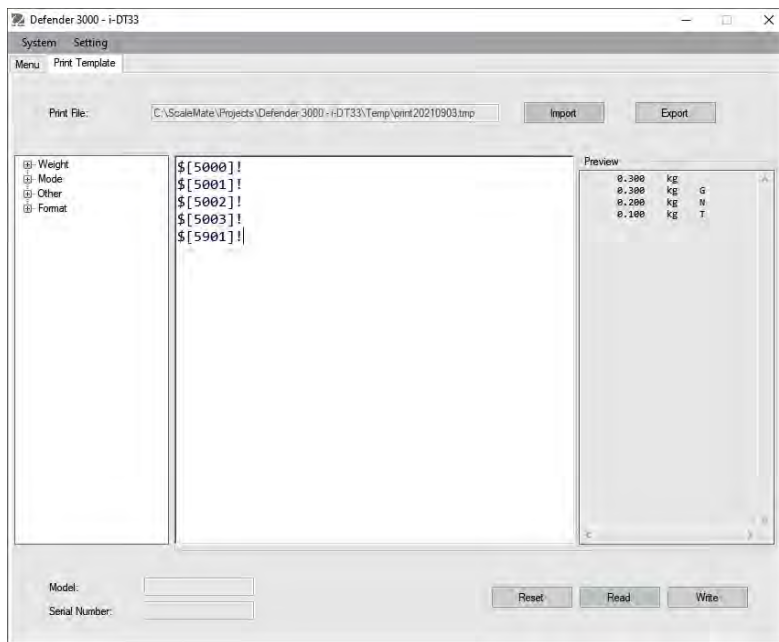

Note: Contact an authorized OHAUS dealer to obtain the ScaleMate software and learn more about the software's other functions.

Alternatively, you can also input the index number of the print items in the middle column directly to customize your print template in the software, using `$$[XXXX]!` format. XXXX refers to the index number of each print item. Please check the following table for each item's index number.

Index Number	Print Items
5000	Result
5001	Gross
5002	Net
5003	Tare
5004	Displayed Weight
5005	Displayed Digit
5300	Mode
5301	Information (APW value in Counting; Under and Over Value in Check; Totalization result in Total)
5403	Indicator's Serial Number
5900	New Line
5901	End of Template
5902	Header Line 1
5903	Header Line 2
5904	Header Line 3
5905	Header Line 4
5906	Header Line 5

4.6.3 USB Configuration

Please refer to USB Configuration in the *Defender™ 3000 USB Interface Instruction Manual*.

4.6.4 Ethernet Configuration

Please refer to Configuration in the *Defender™ 3000 Ethernet Interface Instruction Manual*.

4.7 Lock Button Configuration

This menu **L.O.C.K.** is used to lock access to certain buttons. When you select ON for one selection, the associated button press will be ignored.

If you select **Lock All Keys**, you will lose function of all buttons.

If the **Menu** button has been locked, long press the **Menu** button for 15 seconds until you see **UN.LOCK.** Press the **Yes** button to confirm.

Item	Available Settings (bold is the default settings)
Lock All Keys [L.ALL]	OFF, ON
Lock Off Key [L.OFF]	OFF, ON
Lock Zero Key [L.ZER0]	OFF, ON
Lock Print Key [L.Prnt]	OFF, ON
Lock Unit Key [L.UNIT]	OFF, ON
Lock Mode Key [L.Mode]	OFF, ON
Lock Menu Key [L.MENU]	OFF, ON
Lock Tare key [L.TARE]	OFF, ON
Reset	NO, YES

5. LEGAL FOR TRADE

When the indicator is used in trade or a legally controlled application, it must be set up, verified and sealed in accordance with local weights and measures regulations. It is the responsibility of the purchaser to ensure that all pertinent legal requirements are met.

5.1 Settings

Before verification and sealing, perform the following steps:

1. Verify that the menu settings meet the local weights and measures regulations.
2. Perform a calibration as explained in **Calibration Menu** section.
3. Turn the indicator off.

To turn the security switch on:

1. Disconnect power from the indicator and open the housing as demonstrated in **Open the Housing** section.

Note:

- Remove dry batteries for i-DT33P if used.
 - Remove the lead-acid battery if it is included in your i-DT33P model. Please refer to **Open the Housing** section **i-DT33P (with Lead-acid Battery)** sub-section for instruction.
 - Remove the first layer built-in housing including the lead-acid battery for i-DT33XW. Please refer to **Scale Base without EasyConnect™** section for instruction.
2. Turn the position of the security switch (S1) to ON. Refer to the following two graphics for the location of S1.

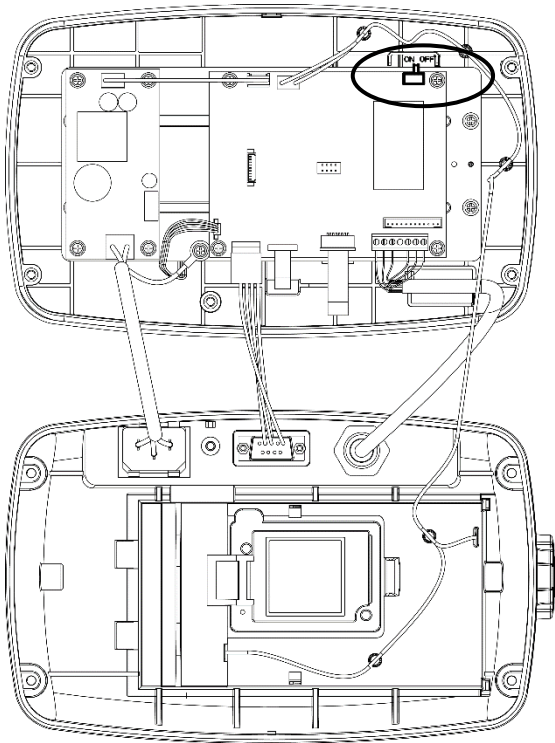

Figure 5-1 i-DT33P Security Switch (S1)
Location

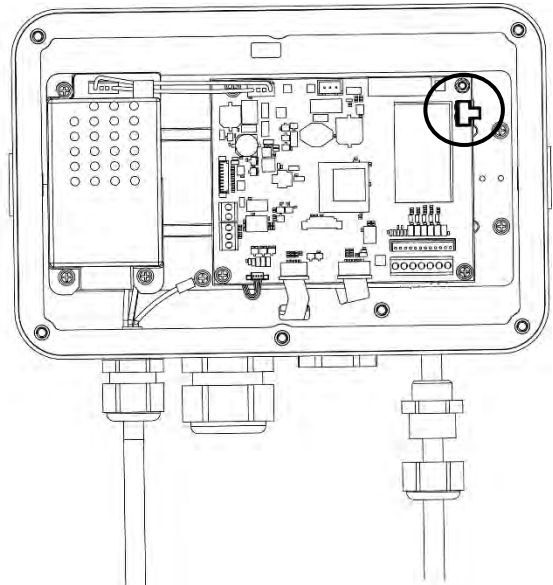

Figure 5-2 i-DT33XW Security Switch (S1)
Location

3. Close the housing. Re-install the lead-acid battery/dry batteries mentioned in step 1.
4. Reconnect the power and turn the indicator on.

5.2 Verification

The local weights and measures official or authorized service agent must perform the verification procedure.

5.3 Sealing

After the scale has been verified, it must be sealed to prevent undetected access to the legally controlled settings. The sealing is different depends on the base connection method. Refer to the instructions below for an appropriate sealing method.

5.3.1 Sealing for Base without EasyConnect

If the terminal connects to a base without EasyConnect (refer **Error! Reference source not found. Error! Reference source not found.**), the scale can be sealed using Wire Sealing (figure 5-3 and 5-5) or Paper Sealing (figure 5-4 and 5-6).

5.3.2 Sealing for an EasyConnect Base with Memory Module

When the i-DT61PW or i-DT61XWE indicator is connected to an OHAUS Defender 3000 series base boasting EasyConnect™ function and has a memory module on the load cell cable(refer Figure 5-7 and 5-8), seal the scale using using Wire Sealing ((figure 5-3 and 5-5) or Paper Sealing (figure 5-4 and 5-6).

The connection cable does not need hardware sealing because it is sealed by software pairing. Once the indicator or the base is replaced by a new one, an error message (**Error 8.90**) will pop up in the indicator's displayed window.

Notice: If it uses an external connection such as EasyConnect to connect a base **without memory module**, the completed scale **CANNOT** be used in Legal For Trade because the connection between the indicator and the base cannot be sealed in physical and software methods.

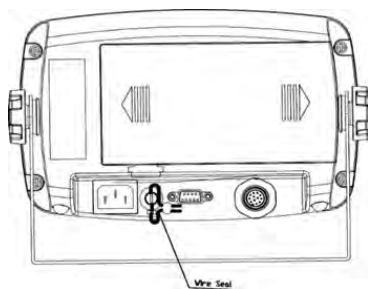

Figure 5-3. i-DT33P Wire Sealing

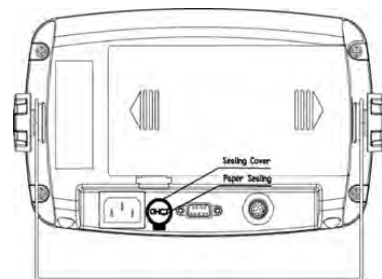

Figure 5-4. i-DT33P paper Sealing

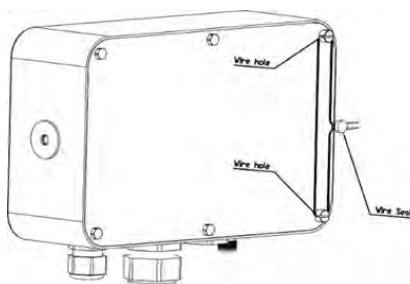

Figure 5-5. i-DT33XW Wire Sealing

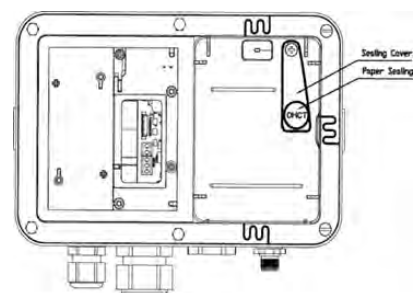

Figure 5-6. i-DT33XW Paper Sealing

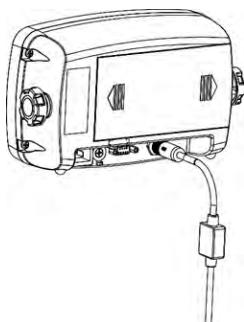

Figure 5-7. i-DT33P Sealing (Connecting cable with connector and memory module)

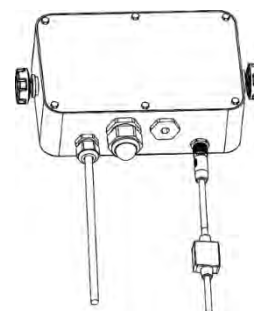

Figure 5-8. i-DT33XW Sealing (Connecting cable with connector and memory module)

6. MAINTENANCE

CAUTION: DISCONNECT THE UNIT FROM THE POWER SUPPLY BEFORE CLEANING.

6.1 Cleaning

For i-DT33P, the housing may be cleaned with a cloth dampened with a mild detergent if necessary.

For i-DT33XW, use approved cleaning solutions for the stainless-steel Indicator housing and rinse with water. Dry thoroughly.



WARNING: Electric Shock Hazard. Disconnect the equipment from the power supply before cleaning.

Make sure that no liquid enters the interior of the instrument.



Attention: Do not use solvents, harsh chemicals, ammonia or abrasive cleaning agents.

6.2 Troubleshooting

TABLE 6-1 Troubleshooting

SYMPTOM	PROBABLE CAUSE (s)	REMEDY
EEP Error	EEPROM Checksum Error	Corrupted EEPROM data
Unable to turn on the indicator.	<ol style="list-style-type: none"> Power cord not plugged in or properly connected. Power outlet not supplying electricity. Battery discharged. Other failure. 	<ol style="list-style-type: none"> Check power cord connections. Make sure power cord is plugged in properly into the power outlet. Check power source. Recharge battery. Service required.
Cannot zero the scale, or will not zero when turned on the indicator.	<ol style="list-style-type: none"> Weights on the pan exceeds allowable limits. Weight is not stable. Load cell is damaged. 	<ol style="list-style-type: none"> Remove weights on the pan. Wait for weight to become stable, check area around the scale and weight on scale for excessive vibration or movement, or increase filtering. Service required.
Unable to calibrate.	<ol style="list-style-type: none"> LFT security switch is turned on. Incorrect value for calibration mass. 	<ol style="list-style-type: none"> Turn the LFT security switch off. Use correct calibration mass.
Cannot display weight in desired weighing unit.	Unit is disabled.	Enable unit in the Units Menu. Refer to Unit Menu section for help.
Cannot change menu settings.	The Menu button has been locked.	<ol style="list-style-type: none"> Enable the Menu button in the L.O.C.F. Menu. The LFT security switch may need to be switched off.
Error 8.1	Weight reading exceeds Power On Zero limit.	<ol style="list-style-type: none"> Remove weight from the pan. Recalibrate the scale.
Error 8.2	Weight reading below Power On Zero limit.	<ol style="list-style-type: none"> Add weight to the pan. Recalibrate the scale.
Error 8.3	Weight reading exceeds Overload limit.	Reduce weight on the pan.
Error 8.4	Weight reading below Underload limit.	<ol style="list-style-type: none"> Add weight to the pan. Recalibrate the scale.
Error 8.7	The EasyConnect™ base is connected to a powered indicator.	Power off the scale completely, reconnect EasyConnect™ cable, power on again.
Error 8.8	Factory calibration data in the EasyConnect™ module on load cell cable is not valid under LFT off status.	Calibrate the scale.
Error 8.90	The serial number of EasyConnect™ base does not match the serial number stored inside indicator under LFT ON status.	Switch back the original EasyConnect™ base.
Error 8.91	Fail to read data from the EasyConnect™ module under LFT ON status.	<ol style="list-style-type: none"> Check if the cable connection is ok. Break the seal, perform factory reset and recalibrate the scale.

Error 8.92 Error 8.94	Incorrect data from EasyConnect™ base under LFT ON status.	1. Break the seal or replace the original base/indicator. 2. Service required.
Error 8.93	The EasyConnect™ base is connected to a blank indicator under the LFT ON status.	Break the seal, connect base to the indicator and power on the scale. Power off the scale and perform sealing again.
Error 9.5	Calibration data not presented.	Calibrate the scale.
Battery symbol flashing	Low battery	Replace dry batteries for i-DT33P model or recharge battery for i-DT33XW model.
ERR E	Calibration value outside allowable limits	Use correct calibration weight.
REF Err	The average piece of weight (APW) on the pan is too small and less than 0.1d.	Replace a heavier batch of samples or change to a scale with readability suitable for your samples.

Note: Please refer to the **LEGAL FOR TRADE** chapter, **Settings** section for the position of the LFT security switch for each model.

6.3 Technical Support Information

If the troubleshooting section does not resolve your problem, contact an Authorized Ohaus Service Agent. Please visit our website to locate the Ohaus office nearest you.

7. TECHNICAL DATA

7.1 Specifications

Equipment Ratings:

Indoor use only	
Altitude:	2,000m
Operating temperature:	-10°C to 40°C
Humidity:	Maximum relative humidity 80% for temperatures up to 31 °C decreasing linearly to 50% relative humidity at 40°C.
Electrical supply:	100 - 240V~, 0.5A, 50/60Hz
Voltage fluctuations:	Mains supply voltage fluctuations up to ±10% of the nominal voltage.
Overvoltage category (Installation category):	II
Pollution degree:	2

TABLE 7-1 Specifications

Model	i-DT33P
Construction	ABS plastic housing, powder coated carbon steel bracket
Maximum displayed resolution	1:30,000
Maximum approved resolution	1:10,000 or 2 × 3,000e Class III @ 1 μV/e (EC, OIML); 1:6,000 (NTEP/Measurement Canada) Class III
Weighing units	Kilogram, Gram, Pound, Ounce, Pound: Ounce, Tonne (Metric Tonne)
Modes	Weighing, Counting, Check, Totalization
Display	45 mm / 1.8 in digit height LCD display with 4-color backlight
Check indicator	3 color (red, green, yellow) bar
Keyboard	4 button membrane keyboard
Auto-zero tracking	Off, 0.5 d, 1 d or 3 d
Load cell excitation voltage	5VDC
Load cell drive	Up to 6 X 350 ohm
Load cell input sensitivity	Up to 3 mV/V
Stabilization time	1 second
Power	9 VDC, 6 dry cells, size C; 6 VDC rechargeable battery; 100-240 VAC / 50-60 Hz internal power supply (depending on models)
Battery life	Dry cell battery: up to 200 hours continuous use with backlight off Rechargeable battery: up to 100 hours continuous use with backlight off
Interface	RS232 standard, Optional USB device or Ethernet
Shipping dimensions	300 x 265 x 135 mm 11.8 x 10.4 x 5.3 in
Product dimensions (with bracket)	252 x 176 x 80 mm / 9.9 x 6.9 x 3.1 in
Approx. net weight	1.3 kg / 2.9 lb
Approx. shipping weight	1.6 kg / 3.5 lb
Operating temperature range	-10°C to 40°C / 14°F to 104°F

Model	i-DT33XW
Construction	304 stainless steel housing, 304 stainless steel bracket
Protection	IP66
Maximum displayed resolution	1:30,000
Maximum approved resolution	1:10,000 or 2 x 3,000e Class III @ 1 μ V/e (EC, OIML) 1:6,000 (NTEP/Measurement Canada) Class III
Weighing units	Kilogram, Gram, Pound, Ounce, Pound: Ounce, Tonne (Metric Tonne)
Modes	Weighing, Counting, Check, Totalization
Display	45 mm / 1.8 in digit height LCD display with 4-color backlight
Check indicator	3 color (red, green, yellow) bar
Keyboard	4 button membrane keyboard
Auto-zero tracking	Off, 0.5 d, 1 d or 3 d
Load cell excitation voltage	5VDC
Load cell drive	Up to 6 X 350 ohm
Load cell input sensitivity	Up to 3 mV/V
Stabilization time	1 second
Power	6 VDC rechargeable battery; 100-240 VAC / 50-60 Hz internal power supply
Battery life	Up to 100 hours continuous use with backlight off
Interface	RS232 standard, Optional USB device or Ethernet
Shipping dimensions	300 x 265 x 135 mm 11.8 x 10.4 x 5.3 in
Product dimensions (with bracket)	260 x 204 x 74 mm / 10.2 x 8.0 x 2.9 in
Approx. net weight	3.1 kg / 6.8 lb
Approx. shipping weight	3.4 kg / 7.5 lb
Operating temperature range	-10°C to 40°C / 14°F to 104°F

7.2 Accessories and Options

TABLE 7-2 Options

P/N	Description
80500525	Cable RS232 i-DT33P
80500552	Cable RS232 i-DT33XW
30692384	DB9 Adapter, Male to Male
30699122	Rechargeable Battery Kit (i-DT33P)
30699121	Dust Cover
30699120	USB Device Kit
30429666	Ethernet Kit



The Rechargeable Battery Kit, USB Device Kit and Ethernet Kit must be installed by a qualified technician.





7.3 Table of Geo Code Values

TABLE 7-1 GEO CODES

Latitude		Elevation in meters										
		0	325	650	975	1300	1625	1950	2275	2600	2925	3250
		325	650	975	1300	1625	1950	2275	2600	2925	3250	3575
		Elevation in feet										
Latitude		0	1060	2130	3200	4260	5330	6400	7460	8530	9600	10660
		1060	2130	3200	4260	5330	6400	7460	8530	9600	10660	11730
		GEO value										
0°00'	5°46'	5	4	4	3	3	2	2	1	1	0	0
5°46'	9°52'	5	5	4	4	3	3	2	2	1	1	0
9°52'	12°44'	6	5	5	4	4	3	3	2	2	1	1
12°44'	15°06'	6	6	5	5	4	4	3	3	2	2	1
15°06'	17°10'	7	6	6	5	5	4	4	3	3	2	2
17°10'	19°02'	7	7	6	6	5	5	4	4	3	3	2
19°02'	20°45'	8	7	7	6	6	5	5	4	4	3	3
20°45'	22°22'	8	8	7	7	6	6	5	5	4	4	3
22°22'	23°54'	9	8	8	7	7	6	6	5	5	4	4
23°54'	25°21'	9	9	8	8	7	7	6	6	5	5	4
25°21'	26°45'	10	9	9	8	8	7	7	6	6	5	5
26°45'	28°06'	10	10	9	9	8	8	7	7	6	6	5
28°06'	29°25'	11	10	10	9	9	8	8	7	7	6	6
29°25'	30°41'	11	11	10	10	9	9	8	8	7	7	6
30°41'	31°56'	12	11	11	10	10	9	9	8	8	7	7
31°56'	33°09'	12	12	11	11	10	10	9	9	8	8	7
33°09'	34°21'	13	12	12	11	11	10	10	9	9	8	8
34°21'	35°31'	13	13	12	12	11	11	10	10	9	9	8
35°31'	36°41'	14	13	13	12	12	11	11	10	10	9	9
36°41'	37°50'	14	14	13	13	12	12	11	11	10	10	9
37°50'	38°58'	15	14	14	13	13	12	12	11	11	10	10
38°58'	40°05'	15	15	14	14	13	13	12	12	11	11	10
40°05'	41°12'	16	15	15	14	14	13	13	12	12	11	11
41°12'	42°19'	16	16	15	15	14	14	13	13	12	12	11
42°19'	43°26'	17	16	16	15	15	14	14	13	13	12	12
43°26'	44°32'	17	17	16	16	15	15	14	14	13	13	12
44°32'	45°38'	18	17	17	16	16	15	15	14	14	13	13
45°38'	46°45'	18	18	17	17	16	16	15	15	14	14	13
46°45'	47°51'	19	18	18	17	17	16	16	15	15	14	14
47°51'	48°58'	19	19	18	18	17	17	16	16	15	15	14
48°58'	50°06'	20	19	19	18	18	17	17	16	16	15	15
50°06'	51°13'	20	20	19	19	18	18	17	17	16	16	15
51°13'	52°22'	21	20	20	19	19	18	18	17	17	16	16
52°22'	53°31'	21	21	20	20	19	19	18	18	17	17	16
53°31'	54°41'	22	21	21	20	20	19	19	18	18	17	17
54°41'	55°52'	22	22	21	21	20	20	19	19	18	18	17
55°52'	57°04'	23	22	22	21	21	20	20	19	19	18	18
57°04'	58°17'	23	23	22	22	21	21	20	20	19	19	18
58°17'	59°32'	24	23	23	22	22	21	21	20	20	19	19
59°32'	60°49'	24	24	23	23	22	22	21	21	20	20	19
60°49'	62°90'	25	24	24	23	23	22	22	21	21	20	20
62°90'	63°30'	25	25	24	24	23	23	22	22	21	21	20
63°30'	64°55'	26	25	25	24	24	23	23	22	22	21	21
64°55'	66°24'	26	26	25	25	24	24	23	23	22	22	21
66°24'	67°57'	27	26	26	25	25	24	24	23	23	22	22
67°57'	69°35'	27	27	26	26	25	25	24	24	23	23	22
69°35'	71°21'	28	27	27	26	26	25	25	24	24	23	23
71°21'	73°16'	28	28	27	27	26	26	25	25	24	24	23
73°16'	75°24'	29	28	28	27	27	26	26	25	25	24	24
75°24'	77°52'	29	29	28	28	27	27	26	26	25	25	24
77°52'	80°56'	30	29	29	28	28	27	27	26	26	25	25
80°56'	85°45'	30	30	29	29	28	28	27	27	26	26	25
85°45'	90°00'	31	30	30	29	29	28	28	27	27	26	26

8. COMPLIANCE

Compliance to the following standards is indicated by the corresponding mark on the product.

Mark	Standard
	This product complies with the applicable harmonized standards of EU Directives 2011/65/EU (RoHS), 2014/30/EU (EMC), 2014/35/EU (LVD) and 2014/31/EU (NAWI). The EU Declaration of Conformity is available online.
	This product complies with the applicable statutory standards of the Restriction of the Use of Certain Hazardous Substances in Electrical and Electronic Equipment Regulations 2012, UK Electromagnetic Compatibility Regulations 2016, Electrical Equipment (Safety) Regulations 2016 and Non-Automatic Weighing Instruments Regulations 2016. The UK Declaration of Conformity is available online.
	This product complies with the EU Directive 2012/19/EU (WEEE) and 2006/66/EC (Batteries). Please dispose of this product in accordance with local regulations at the collecting point specified for electrical and electronic equipment. For disposal instructions in Europe, refer to the OHAUS website.
	EN 61326-1
	UL 61010-1 CAN/CSA-C22.2 No. 61010-1

ISED Canada Compliance Statement:

CAN ICES-003(A) / NMB-003(A)

ISO 9001 Registration

The management system governing the production of this product is ISO 9001 certified.

9. APPENDICES

9.1 Appendix A

MT Standard Continuous Output

A checksum character can be enabled or disabled with continuous output. The data consists of 17 or 18 bytes as shown in the standard continuous output.

Table 9-1.

Non-significant weight data and tare data digits are transmitted as spaces. The continuous output mode provides compatibility with OHAUS products that require real-time weight data. the standard continuous output. Table 9-1 shows the format for the standard continuous output.

Table 9-1: Standard Continuous Output Format

		Status ²			Indicated Weight ³					Tare Weight ⁴								
Character	1	2	3	4	5	6	7	8	9	10	11	12	13	14	15	16	17	18
Data	STX ¹	SB-A	SB-B	SB-C	MSD	-	-	-	-	LSD	MSD	-	-	-	-	LSD	CR ⁵	CHK ⁶

Continuous Output Format Notes:

1. ASCII Start of Text character (02 hex), always transmitted.
2. Status bytes A, B and C. Refer to Table 5-2, Table 5-3, and Table 5-4 for details of the structure.
3. Displayed weight. Either gross or net weight. Six digits, no decimal point or sign. Insignificant leading zeroes are replaced with spaces.
4. Tare weight. Six digits of tare weight data. No decimal point in field.
5. ASCII Carriage Return <CR> character (0D hex).
6. Checksum, transmitted only if enabled in setup. Checksum is used to detect errors in the transmission of data. Checksum is defined as the 2's complement of the seven low order bits of the binary sum of all characters preceding the checksum character, including the <STX> and <CR> characters.

Table 9-2, Table 9-3, and Table 9-4 detail the status bytes for standard continuous output.

Table 9-2: Status Byte A Bit Definitions

Bits 2, 1, and 0			
2	1	0	Decimal Point Location
0	0	0	XXXXXX00
0	0	1	XXXXXX0
0	1	0	XXXXXX
0	1	1	XXXXX.X
1	0	0	XXXX.XX
1	0	1	XXX.XXX
1	1	0	XX.XXXX
1	1	1	X.XXXXX
Bits 4 and 3			
4	3	Build Code	
0	1	X1	
1	0	X2	
1	1	X5	
Bit 5			Always = 1
Bit 6			Always = 0

Table 9-3: Status Byte B Bit Definitions

Status Bits	Function
Bit 0	Gross = 0, Net = 1
Bit 1	Sign, Positive = 0, Negative = 1
Bit 2	Out of Range = 1 (Over Capacity or Under Zero)
Bit 3	Motion = 1, Stable = 0
Bit 4	lb = 0, kg = 1 (see also Status Byte C, bits 0, 1, 2)
Bit 5	Always = 1
Bit 6	Zero Not Captured after power-up = 1

Table 9-4: Status Byte C Bit Definitions

Bits 2, 1, and 0			Weight Description
2	1	0	
0	0	0	lb or kg, selected by Status Byte B, bit 4
0	0	1	grams (g)
0	1	0	metric tons (t)
0	1	1	ounces (oz)
1	0	0	not used
1	0	1	not used
1	1	1	tons (ton)
1	1	1	no units
Bit 3			Print Request = 1
Bit 4			Expand Data x 10 = 1, Normal = 0
Bit 5			Always = 1
Bit 6			Always = 0

9.2 Appendix B

MT-SICS Commands

	Command	Function
LEVEL 0	I0	Inquiry of all available SICS commands
	I1	Inquiry of SICS level and SICS versions
	I2	Inquiry of scale data
	I3	Inquiry of scale software version
	I4	Inquiry of serial number
	S	Send stable weight value
	SI	Send weight value immediately
	SIR	Send weight value repeatedly
	Z	Zero the scale
	ZI	Zero immediately
LEVEL 1	D	Write text into display
	DW	Weight display
	SR	Send and repeat stable weight value
	T	Tare
	TA	Tare value
	TAC	Clear tare
	TI	Tare immediately

	Command	Function
LEVEL 2	C2	Calibrate with the external calibration weight
	I10	Inquire or set scale ID
	I11	Inquire of scale type
	P101	Print out stable weight value
	P102	Print out current weight value immediately
	SIRU	Send weight value in the current unit immediately and repeat
	SIU	Send weight value in the current unit immediately
	SNR	Send stable weight value and repeat after every weight change
	SNRU	Send stable weight value in the current unit and repeat after every weight change
	SRU	Send weight value in the current unit and repeat
	SU	Send stable weight value in the current unit
LEVEL 3	M01	Weighing mode
	M02	Stability setting
	M03	Autozero function
	M19	Send calibration weight
	M21	Inquire/set weight unit
	RST	Restart
	SFIR	Send weight value immediately and repeat quickly
	SIH	Send weight value immediately in high resolution
	SWU	Switch weight unit
	SX	Send stable data record
	SXI	Send data record immediately
	SXIR	Send data record immediately and repeat
	U	Switch weight unit

9.3 Appendix C

Commands listed in the following table will be acknowledged by the scale.

The scale will return "ES" for invalid commands.

Please add `\r\n` after each command to send. (`\r` refers to `\return`; `\n` refers to `\newline`)

OHAUS Commands

Command	Function
P	Print displayed weight (stable or unstable).
IP	Print displayed weight immediately (stable or unstable).
CP	Print weight continuously.
SP	Print weight when stable.
Z	Same as pressing Zero Key.
T	Same as pressing Tare Key.
TA	Set/inquiry of tare weight value. <ul style="list-style-type: none"> Set: TA <i>tare value unit</i> Example: TA 5 kg Inquiry: TA
U	Set/inquiry current display unit. <ul style="list-style-type: none"> Set: U <i>unit ID</i> Example: U 1 Please check the following table 9-1 for the ID of each unit. Inquiry: U
M	Set/inquiry current application mode. <ul style="list-style-type: none"> Set: M <i>application ID</i> Example: M 0 Please check the following table 9-2 for the ID of each application. Inquiry: M
PSN	Print indicator's serial number.
CU	Set/inquiry Under Limit (only in Check mode). <ul style="list-style-type: none"> Set: CU <i>under value unit</i> Example: CU 5 kg Inquiry: CU
CO	Set/inquiry Over Limit (only in Check mode). <ul style="list-style-type: none"> Set: CO <i>over value unit</i> Example: CO 6 kg Inquiry: CO
#	Set/inquiry Counting APW. <ul style="list-style-type: none"> Set: # <i>APW value unit</i> Example: # 6 kg Inquiry: #
PV	Print name, software revision and LFT ON (if LFT security switch is turned ON).
H x "text"	Enter print output string, x = string number (1-5), "text" = string text up to 40 alphanumeric characters.

Note:

- The italic content in each command needs to be filled with actual value.
- Space in each command is needed. Please pay attention to it when input commands.

Table 9-1 Unit ID

Unit ID	Unit Name	Abbreviation
0	Gram	g
1	Kilogram	kg
2	Ton	t
7	Pound	lb
8	Ounce	oz
20	Pound:Ounces	lb:oz

Table 9-2 Application ID

Application ID	Unit Name
0	Weighing
1	Counting
3	Check
6	Totalization

9.4 Appendix D

Printout string for g, kg, lb, oz units:

Check Weighing application:

Field	Weight (Right aligned)	Space	Unit (Right aligned)	Space	Stability (?)	Space	T/N/G/PT (Right aligned)	Space	Application Status (Right aligned)	Term.
Length	11	1	5	1	1	1	2	1	6	2

Non-Check Weighing application:

Field	Weight (Right aligned)	Space	Unit (Right aligned)	Space	Stability (?)	Space	T/N/G/PT (Right aligned)	Term.
Length	11	1	5	1	1	1	2	2

Each field is followed by a single delimiting space (ASCII: 32).

Definitions:

Weight - Up to 11 characters, right justified, - at immediate left of most significant character (if negative).

Unit - Up to 5 characters, right justified. If the Unit in the Print Content menu was set to OFF, the unit will be removed in the weight string and replaced by spaces.

Stability - "?" character is printed if not stable. If weight is a space is printed.

T/N/G/PT - "T" is printed for a tare weight, "N" printed if weight is net weight, 'G' or nothing printed if weight is a gross weight, 'PT' is printed if the tare weight is Pre-set Tare.

Application Status (for Check) – Fixed to 6 characters. Display status like " Under", "Accept" and "Over" for check weighing.

Terminating Character(s) - Termination Characters Carriage Return and Line Feed are appended to the printout.

Printout string for the lb:oz unit:

Check Weighing application:

Field	Weight1	Space	Unit1 (lb)	Space	Weight2 (oz)	Space	Unit2	Space	Stability	Space	T/N/G/PT (Right aligned)	Space	Application Status (Right aligned)	Term.
Length	a	1	2	1	b	1	2	1	1	1	2	1	6	2

Non-Check Weighing application:

Field	Weight1	Space	Unit1 (lb)	Space	Weight2 (oz)	Space	Unit2	Space	Stability	Space	T/N/G/PT (Right aligned)	Term.Char(s)
Length	a	1	2	1	b	1	2	1	1	1	2	2

- Each Space field is a delimiting space used to separate the other fields.
- The Weight1 field is [a] right justified characters. If the value is negative, the ' - ' character is located at the immediate left of the most significant digit.
- The Unit1 field is 2 left justified characters.
- The Weight2 field is [b] right justified characters.
- [a]+[b] has a fixed length of 10 characters.
- The Unit2 field is 2 left justified characters.
- The Stability field is 1 character. A space is printed if the weight value is stable. A '?' is printed if the weight value is not stable.
- T/N/G/PT - "T" is printed for a tare weight, "N" printed if weight is net weight, 'G' or nothing printed if weight is a gross weight, 'PT' is printed if the tare weight is Pre-set Tare.
- Application Status (for Check) – Fixed to 6 characters. Display status like " Under", "Accept" and "Over" for check weighing.

Note: The Termination Characters Carriage Return and Line Feed are appended to the printout.

LIMITED WARRANTY

OHAUS products are warranted against defects in materials and workmanship from the date of delivery through the duration of the warranty period. During the warranty period OHAUS will repair, or, at its option, replace any component(s) that proves to be defective at no charge, provided that the product is returned, freight prepaid, to OHAUS. This warranty does not apply if the product has been damaged by accident or misuse, exposed to radioactive or corrosive materials, has foreign material penetrating to the inside of the product, or as a result of service or modification by other than OHAUS. In lieu of a properly returned warranty registration card, the warranty period shall begin on the date of shipment to the authorized dealer. No other express or implied warranty is given by OHAUS Corporation. OHAUS Corporation shall not be liable for any consequential damages.

As warranty legislation differs from state to state and country to country, please contact OHAUS or your local OHAUS dealer for further details