

Contents

1	About These Instructions	6
1.1	Validity.....	6
1.2	Target Groups.....	6
1.3	Symbols Used.....	6
1.3.1	Warnings in Operation Descriptions.....	6
1.3.2	Other Symbols Used.....	7
2	Safety Instructions	8
2.1	Intended Use.....	8
2.1.1	Modifications to the Device.....	8
2.1.2	Repairs to the Device.....	8
2.2	Qualifications of Personnel.....	9
2.3	Functionality of the Device Parts.....	9
2.4	Safety Information on the Device.....	9
2.5	Electrical Equipment.....	9
2.5.1	Damage to the Device's Electrical Equipment.....	9
2.5.2	Power Supply Unit and Power Supply Cable.....	9
2.6	Conduct in an Emergency.....	10
2.7	Accessories.....	10
3	Device Description	11
3.1	Device Overview.....	11
3.2	Weighing Pan and Associated Components.....	12
3.3	Connections and Components on the Weighing Module.....	13
3.4	Connections on the Control Unit.....	14
3.5	Conformity-assessed Devices.....	14
3.6	Below-balance Weighing.....	14
4	Operating Design	15
4.1	Operating Elements in the Main Menu.....	15
4.2	Operating Elements in Task Management.....	16
4.3	Status Center.....	17
4.4	User Management.....	18
4.4.1	User Profiles.....	18
4.4.2	User Login.....	18
4.5	Weighing and Print Profiles.....	18
4.6	Applications and Tasks.....	18
4.7	Navigating the Menus.....	18
5	Installation	20
5.1	Scope of Delivery.....	20
5.2	Selecting an Installation Site.....	20
5.3	Unpacking.....	20
5.4	Removing the Control Unit (Optional).....	21
5.5	Preparing Below-balance Weighing (Optional).....	22
5.6	Positioning the Weighing Pan and Associated Components.....	23
5.7	Acclimatizing.....	23

6	Getting Started	24
6.1	Connecting the Ethernet Cable	24
6.2	Installing the Power Supply Unit	24
6.3	Connecting the Power Supply	25
6.4	Connecting Accessories	25
6.5	Attaching Protective Caps and Covers	26
7	System Settings	27
7.1	Switching the Device On/Off and Activating Standby Mode	27
7.2	User Login or Logout	27
7.3	Performing System Settings	28
7.4	Using the Help Function	28
7.5	Activating Applications (QAPPs) and Adding to a Task	28
7.5.1	Activating Applications	28
7.5.2	Adding an Application to a Task	29
7.6	Switching Off the isoCAL Function	29
7.7	Adding Weighing and Print Profiles to a Task	30
7.8	Downloading Additional Information	30
8	Operation	31
8.1	Leveling the Device	31
8.2	Calibration, Adjustment or Linearization	31
8.2.1	Adjusting With the isoCAL Function	32
8.2.2	Internally Calibrating and Adjusting the Device	32
8.3	Preparing Weighings	33
8.4	Weighing	33
8.5	Running Application (Example)	33
8.5.1	Executing the "Unit change" Function	33
9	Cleaning and Maintenance	35
9.1	Preparing the Device for Cleaning	35
9.2	Cleaning the Device	35
9.3	Recommissioning	35
9.4	Performing a Software Update	36
9.5	Performing a QAPP Center Update	36
10	Malfunctions	38
10.1	Warning Messages	38
10.2	Troubleshooting	39
10.3	Operating Issues	39
11	Decommissioning	40
11.1	Decommissioning the Device	40
12	Transport	40
12.1	Transporting the Device	40
13	Storage and Shipping	41
13.1	Storing	41
13.2	Returning the Device and Parts	41
14	Disposal	42
14.1	Disposing of the Device and Parts	42

15	Technical Data	43
15.1	Dimensions and Weight	43
15.1.1	High-capacity Precision Balance	43
15.2	Ambient Conditions During Storage and Transport	43
15.3	Installation Conditions	43
15.3.1	Installation Site	43
15.3.2	Ambient Conditions at the Installation Site	44
15.4	Acclimatization Before Power Supply	44
15.5	Electrical Data	45
15.5.1	Power Supply	45
15.5.2	Safety of Electrical Equipment	45
15.5.3	Electromagnetic Compatibility	46
15.6	Interfaces	46
15.6.1	Specifications for the COM-RS232 Interface	46
15.6.2	Specifications for the USB-A Interface	46
15.6.3	Specifications for the USB-B Interface	46
15.6.4	Specifications for the USB-C Interface	46
15.7	Recommended Calibration Weight	47
15.8	Conditions for isoCAL Function	47
15.9	Data Storage Device	48
15.10	Integrated Clock	48
15.11	Backup Battery	48
15.12	Materials	48
15.13	Cleaning Agents and Cleaning Procedures	49
15.13.1	Approved Cleaning Agents	49
15.13.2	Approved Cleaning Procedures	49
15.14	Metrological Data	50
15.14.1	Models CUB11201S CUB20201S CUB36200S	50
15.14.2	Models CUB36201S CUB36201P CUB50201S	51
15.14.3	Models CUB70200S CUB70201S	52
16	Accessories	53
16.1	Accessories	53
16.1.1	Printers and Communication	53
16.1.2	Filter Balance and Antistatic Accessories	54
16.1.3	Special Applications	54
16.1.4	Weighing Tables	54
16.1.5	Weighing Accessories	54
17	Sartorius Service	55
18	Trademark Information	55
19	Conformity	55
19.1	EU Declaration of Conformity	55

1 About These Instructions

1.1 Validity

These instructions are part of the device; they must be read in full and kept in a safe place. These instructions apply to the device in the following versions:

Device	Model
High-capacity precision balance	CUB11201S-1XX-0 CUB11201S-1XX-0C CUB20201S-1XX-0 CUB20201S-1XX-0C CUB36200S-1XX-0 CUB36200S-1XX-0C CUB36201S-1XX-0 CUB36201S-1XX-0C CUB36201P-1XX-0 CUB36201P-1XX-0C CUB50201S-1XX-0 CUB50201S-1XX-0C CUB70200S-1XX-0 CUB70200S-1XX-0C CUB70201S-1XX-0 CUB70201S-1XX-0C

1.2 Target Groups

These instructions are addressed to the following target groups. The target groups must possess the specified knowledge.

Target Group	Knowledge and Qualifications
Operator	The operator is familiar with the device and the associated work processes. The operator understands the hazards which may arise when working with the device and knows how to prevent them.*

* If a person in the target group operates the software interface of the device, they are also the "user".

1.3 Symbols Used

1.3.1 Warnings in Operation Descriptions

WARNING

Denotes a hazard that may result in death or serious injury if it is **not** avoided.

CAUTION

Denotes a hazard that may result in moderate or minor injury if it is **not** avoided.

NOTICE

Denotes a hazard that may result in property damage if it is **not** avoided.

1.3.2 Other Symbols Used

- ▶ Required action: Describes activities that must be carried out. The activities in the sequence must be carried out in succession.
- ▷ Result: Describes the result of the activities carried out.
- [] Refers to operating and display elements. Indicates status, warning, and error messages.
- M Indicates information for legal metrology for conformity-assessed (verified) devices. Conformity-assessed devices are also referred to as “verified” in these instructions.

Figures in these instructions

Depending on the device configuration, the figures depicting the device and operating display may differ slightly from the supplied device. The variants shown in these instructions are examples.

2 Safety Instructions

2.1 Intended Use

The device is a high-resolution balance, which can be used in laboratories. The device is intended to accurately determine the mass of materials in liquid, paste, powder, or solid form.

Appropriate vessels must be used for loading certain materials.

The device can be operated as follows:

- In individual operation
- Connected to a PC
- Integrated into a network

The device is intended solely for use in accordance with these instructions. Any other use is considered **improper** and can impair the protection supported by the device, e.g., protection against mechanical dangers.

Foreseeable misuse

The following applications are **not** permitted: Operation under any atmosphere other than the normal atmosphere.

Operating conditions for the device

Do **not** use the device in potentially explosive environments. Only use the device indoors.

Do **not** use physical measures to alter the as-delivered state of the device, and only connect approved accessories (see Chapter "16 Accessories", page 53).

The device may only be used with the equipment and under the operating conditions described in the Technical Data section of these instructions.

2.1.1 Modifications to the Device

If the device is modified: Persons may be put at risk. Device-specific documents and product approvals may lose their validity.

For queries regarding modifications to the device, contact Sartorius.

2.1.2 Repairs to the Device

Device repairs may only be carried out by persons with specialized knowledge of the device. If the device is **not** repaired by a specialist: Persons may be put at risk. Device-specific documents and product approvals may lose their validity.

Sartorius recommends that any repair work, even that carried out after the end of the warranty period, is carried out by Sartorius Service or after consulting with Sartorius Service.

2.2 Qualifications of Personnel

Persons who do not possess adequate knowledge about how to use the device may injure themselves and other persons.

If a particular qualification is required for an activity: The target group is specified. If **no** qualification is specified: The activity can be performed by the "Operator" target group.

2.3 Functionality of the Device Parts

Non-functioning device parts, e.g., as a result of damage or wear, can cause malfunctions. There is a risk of injury to persons.

- ▶ If device parts are **not** functioning: Do **not** use the device.

2.4 Safety Information on the Device

Symbols, e.g., warnings and safety stickers, are safety information for handling the device. Missing or illegible safety information may result in this information **not** being observed. There is a risk of injury to persons.

- ▶ Do **not** conceal, remove, or modify the symbols.
- ▶ Replace the symbols if they become illegible.

2.5 Electrical Equipment

2.5.1 Damage to the Device's Electrical Equipment

Damage to the device's electrical equipment, e.g., damaged insulation, can be life-threatening. Contact with live parts represents a danger to life.

- ▶ If the electrical equipment of the device is defective, disconnect the power supply and contact Sartorius Service.
- ▶ Keep live parts away from moisture. Moisture can cause short circuits.

2.5.2 Power Supply Unit and Power Supply Cable

The use of an **unauthorized** power supply unit or power supply cable may cause life-threatening injuries as a result of electric shocks, for example.

- ▶ Only use the original power supply unit and power supply cable.
- ▶ If the power supply unit or power supply cable needs to be replaced: Contact Sartorius Service. Do **not** repair or modify the power supply unit or power supply cable.

2.6 Conduct in an Emergency

If an emergency occurs, e.g., due to malfunctions of the device or dangerous situations: Persons may be injured. The device must be immediately taken out of operation:

- ▶ Disconnect the device from the power supply.
- ▶ Prevent the device from recommissioning.

2.7 Accessories

The use of unsuitable accessories can affect the functionality and operating reliability of the device and has the following consequences:

- Risk of injury to persons
 - Damage, malfunctions, or failure of the device
- ▶ Only use accessories that have been approved by Sartorius for this device.

3 Device Description

3.1 Device Overview

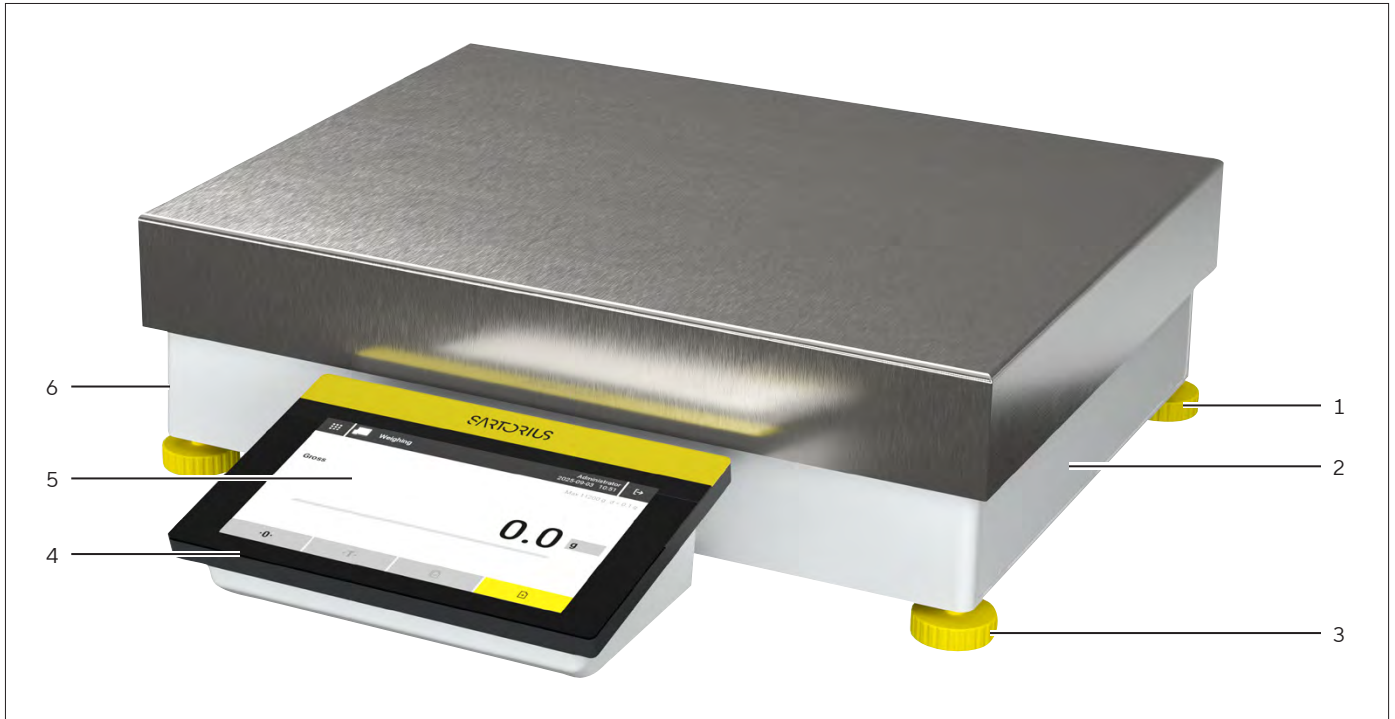

Fig. 1: High-capacity Precision balance with a Rectangular Weighing Pan (example)

Pos.	Name	Description
1	Leveling foot	Is screwed in during leveling.
2	Weighing module	
3	Leveling foot	For manually leveling the device
4	Control unit	
5	Operating display	Intended to operate the software.
6	Manufacturer's ID label	<ul style="list-style-type: none"> – Contains additional information about the device, e.g., serial number and the metrological and technical data. – Not visible.

3.2 Weighing Pan and Associated Components

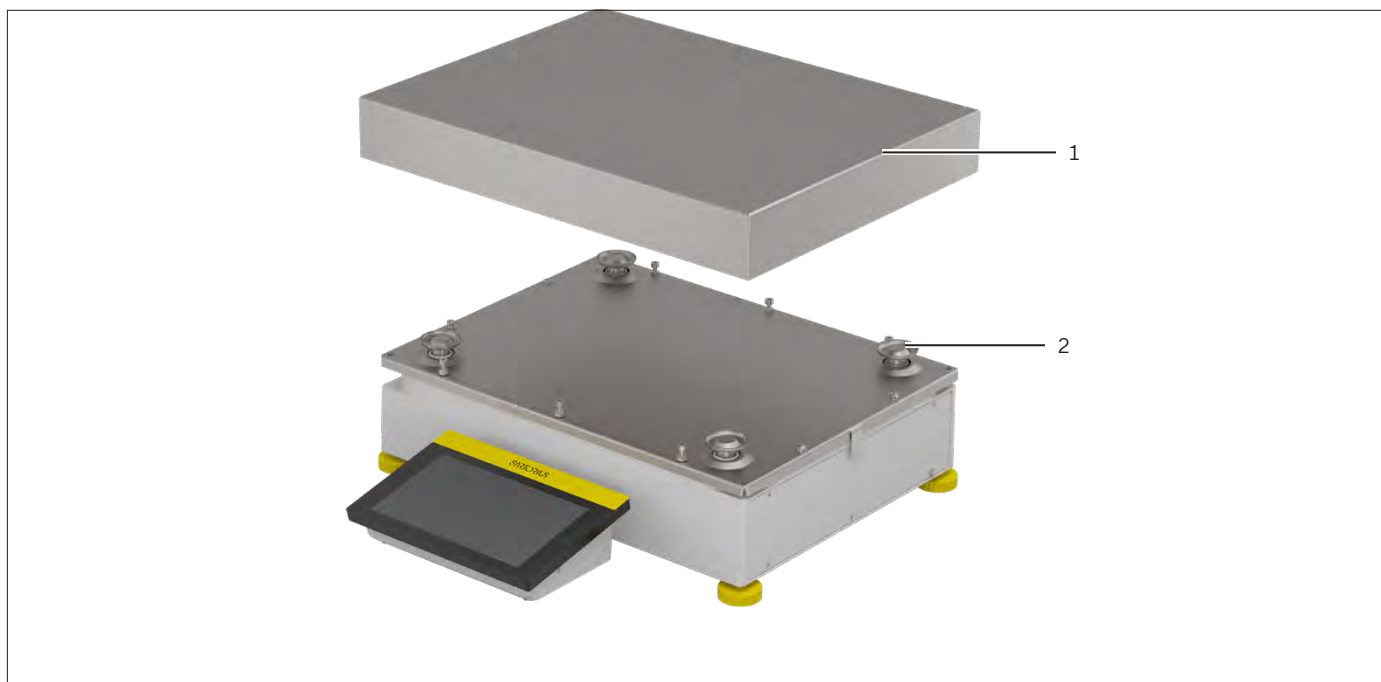

Fig. 2: High-capacity precision balance (example)

Pos.	Name	Description
1	Weighing pan	
2	Pan retainer	

3.3 Connections and Components on the Weighing Module

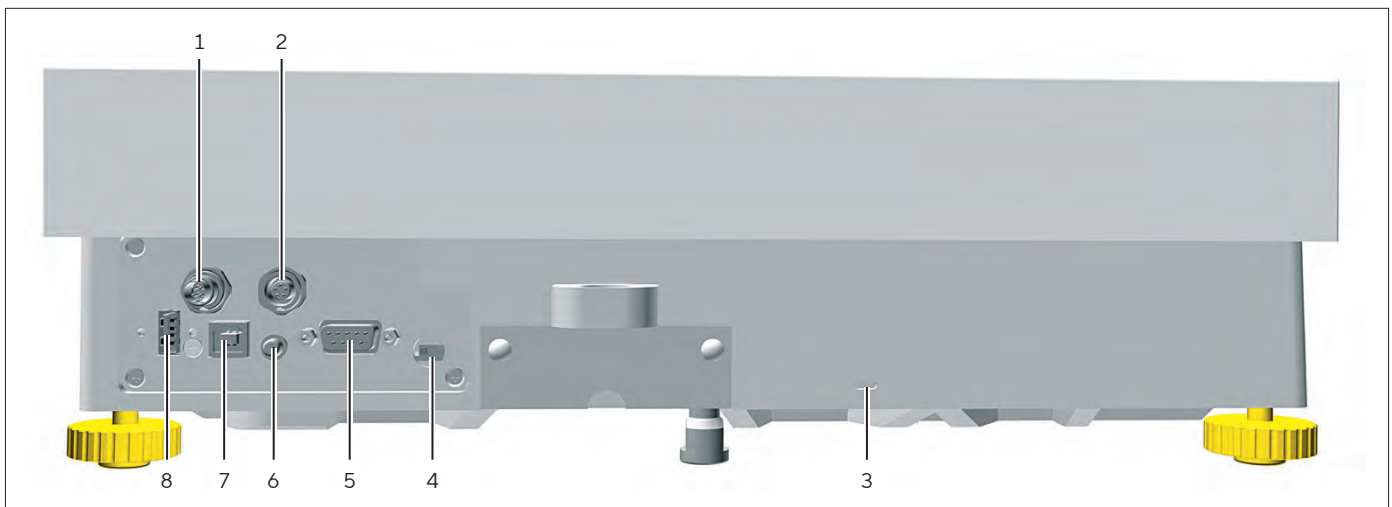

Fig. 3: Connections to the weighing module (example)

Pos.	Name	Description
1	Power supply	For connection to the power supply.
2	Peripheral connection	<ul style="list-style-type: none"> – For connecting accessories. – Sealed with a plastic protective cap. – The protective cap is removable.
3	Slot	For connecting a “Kensington” anti-theft device.
4	Access switch	<ul style="list-style-type: none"> – Protects the device from changes to the device settings. – Is sealed for conformity-assessed devices. – Sealed with a plastic protective cap. – The protective cap is removable.
5	COM-RS232 connection	<ul style="list-style-type: none"> – 9-pin, for connection to a PC or PLC. – Sealed with a plastic protective cap. – The protective cap is removable.
6	On key	Switches the device back on again after switching off via the software.
7	USB-B connection	<ul style="list-style-type: none"> – For connection to a PC. – Sealed with a plastic protective cap. – The protective cap is secured to the device.
8	USB-A connection	<ul style="list-style-type: none"> – For USB accessories, e.g., printers, USB mass storage devices, bar-code scanners. – Sealed with a plastic protective cap. – The protective cap is secured to the device.

3.4 Connections on the Control Unit

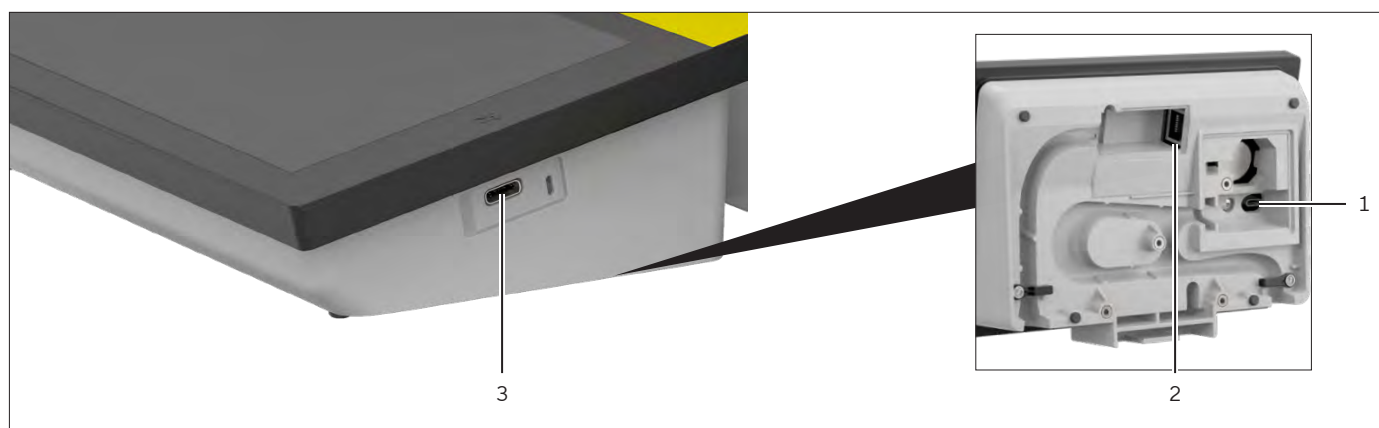

Fig. 4: Connections on the control unit, on the side and base (example)

Pos.	Name	Description
1	Weighing module connection	For connection to the control unit.
2	Ethernet connection	For connection to a network.
3	USB-C connection	For connecting accessories.

3.5 Conformity-assessed Devices

Some settings of conformity-assessed models are protected against operator changes, e.g., “external adjustment”. This measure is intended to ensure the suitability of the devices for use in legal metrology.

3.6 Below-balance Weighing

The device is suitable for below-balance weighing. Samples can be suspended for weighing using below-balance weighing, e.g., samples, which do **not** fit on the weighing pan. Below-balance weighing is possible under the following conditions:

- The device must be set up on a weighing table with recess.
- For below-balance weighing, a below-balance weighing hook must be inserted in the device base. The below-balance weighing hook is available as an accessory (see Chapter “16 Accessories”, page 53).

In legal metrology:

- The below-balance weighing equipment may **not** be used.
- The cover of the below-balance weighing may **not** be removed.

4 Operating Design

4.1 Operating Elements in the Main Menu

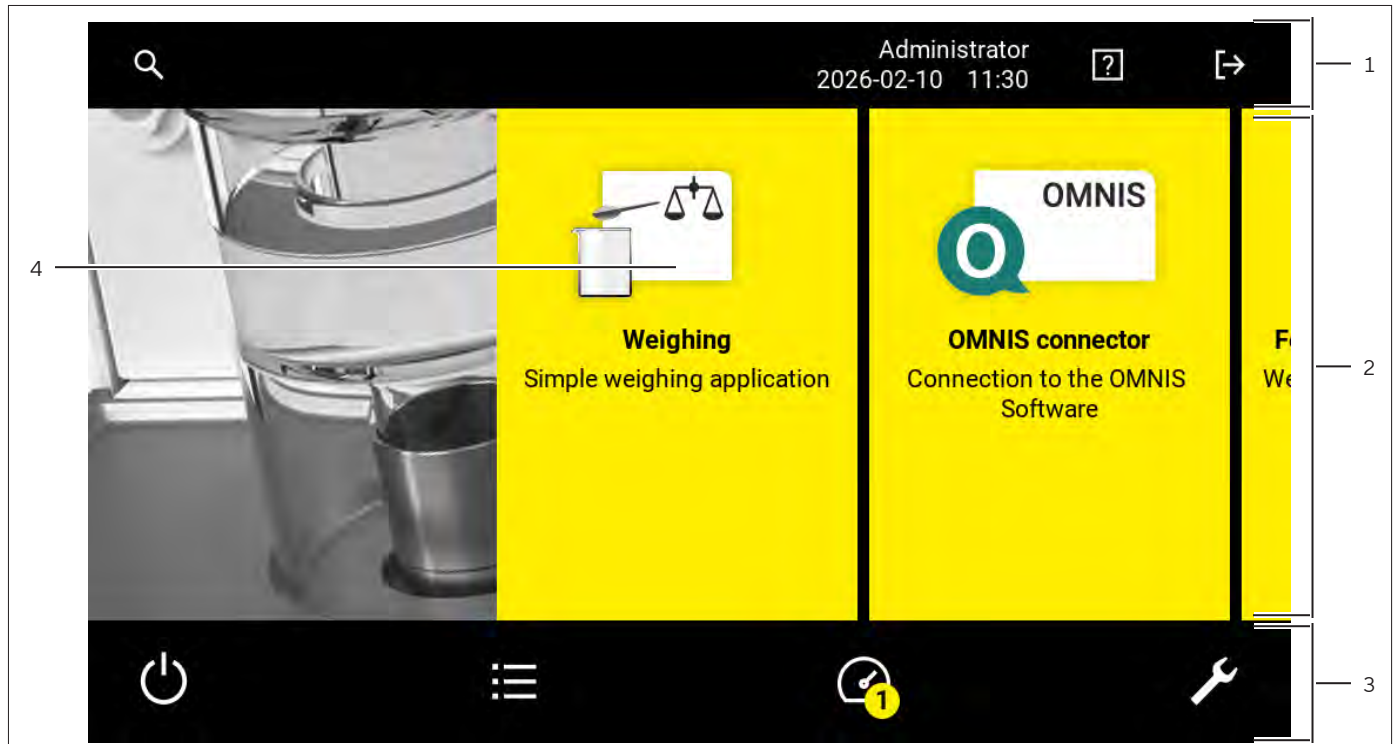

Fig. 5: Operating elements in the main menu (example)

Pos.	Name	Description
1.	Navigation and function bar	<ul style="list-style-type: none"> – Enables navigation and searching in menus and lists. – In the “Settings” menu: Displays the name of the menu.
2.	Available tasks	Displays all tasks available for the active user.
3.	Function bar	Displays available submenus and operating functions for the current display and current user.
4.	Task	Starts the described task.

4.2 Operating Elements in Task Management

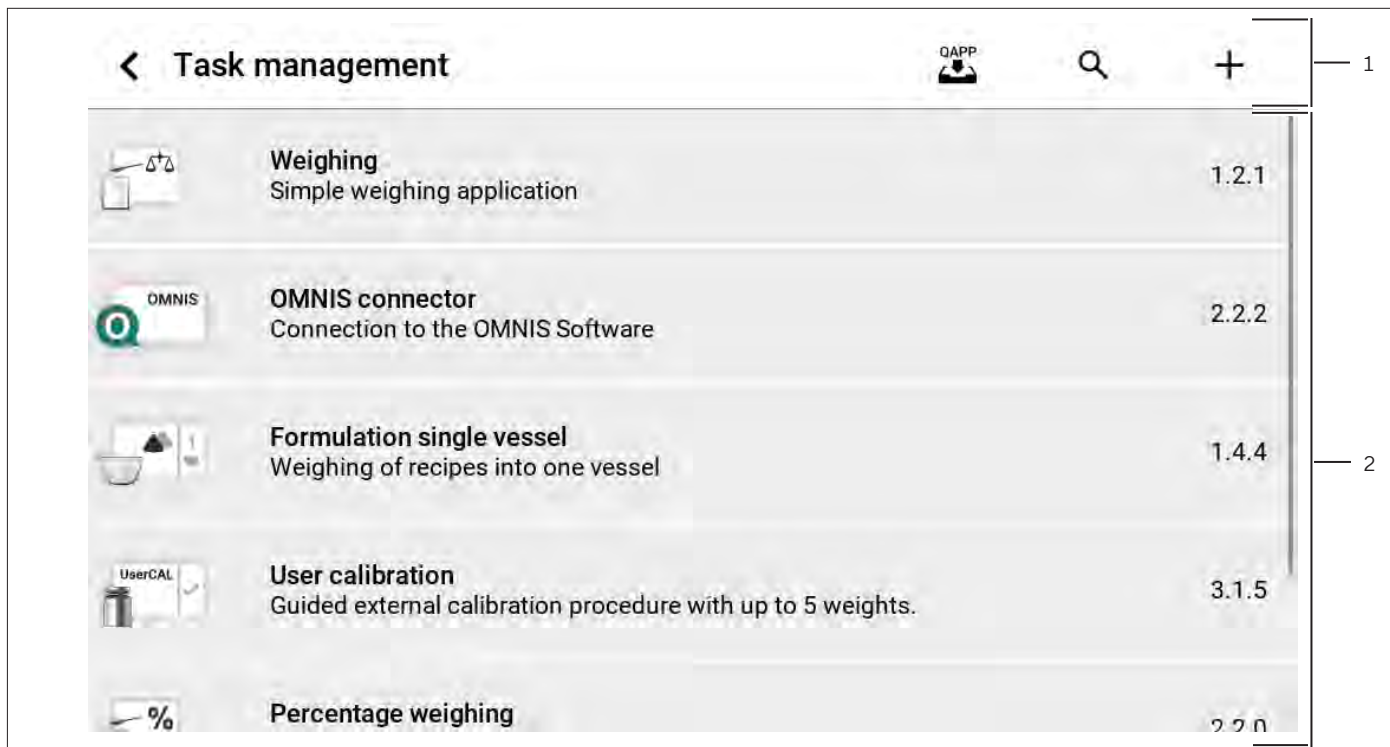

Fig. 6: Operating elements in task management (example)

Pos.	Name	Description
1.	Navigation and function bar	<ul style="list-style-type: none"> – Enables navigation and searching in menus and lists. – Enables the addition of tasks. – Opens the QAPP Center. – Displays the name of the menu.
2.	Available tasks	<ul style="list-style-type: none"> – Displays all available tasks. – Opens a summary of the properties for the displayed task.

4.3 Status Center

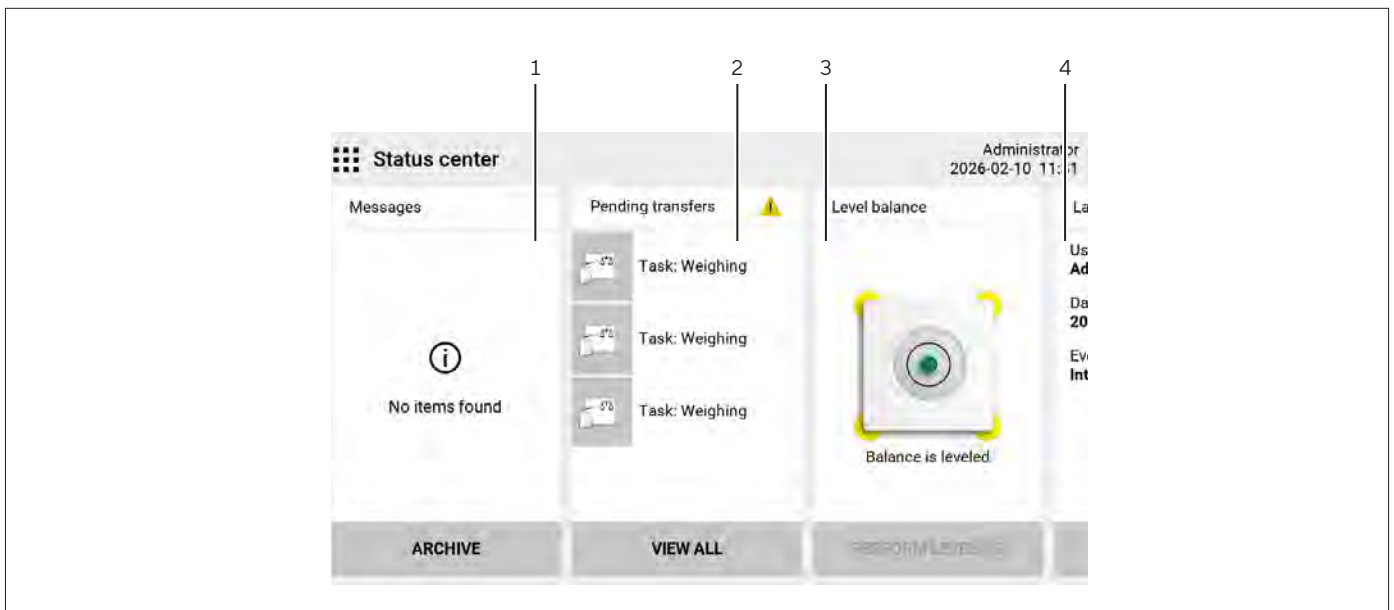

Fig. 7: Status center (example)

Pos.	Name	Description
1	Messages	Displays information, warning, and error messages.
2.	Pending transfer	If there are pending transfers: Displays the pending transfers for completed tasks.
3.	Leveling status	Displays the status of the level, starts leveling.
4.	Further categories	Displays further categories that are made visible when swiping to the left, e.g., <ul style="list-style-type: none"> – Status for the device – Calibration and adjustment report – Audit trail

4.4 User Management

4.4.1 User Profiles

In the factory, four user profiles are created for the device. One role is assigned to each user profile. Each role has rights to operate the device. The rights assigned to each role depend on which device functions the user has to use. User profiles can be adapted.

Additional user profiles, roles, and rights may be activated in the device settings for devices with licensed user management.

4.4.2 User Login

The user must log in to the login display with a user profile. Various setting options and tasks are displayed in the operating display depending on the user profile and role.

4.5 Weighing and Print Profiles

Weighing and print profiles can be created. These profiles can be assigned to a task.

Preset profiles can be used in a task. The preset profiles can be adjusted individually to the application and saved in new profiles for weighing and printing.

4.6 Applications and Tasks

Applications (QAPP applications) are grouped together in QAPP packages. Depending on the model, the device can be supplied with some freely accessible applications. These applications can be used to carry out the most important functions.

Subsequent licensing (package QP99) covers all other applications and can be activated in the QAPP Center for a fee.

An application must be configured as a task before it can be used. Specific settings need to be applied for this, with the help of the assistant function. Tasks are visible to all users who have the required role to perform the task.

4.7 Navigating the Menus

Procedure

- ▶ To open an application or a menu from the main menu:
- ▶ Press the application button or required menu button in the function bar.
- ▷ The application or menu is opened and the name of the open menu is opened in the navigation bar.
- ▶ To return to the main menu from other displays: Press the [Back] or [Menu] button.



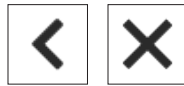

- ▶ To return to the next higher menu level: Press the [Back] or [Cancel] button.



- ▶ To scroll through the available tasks or categories in a horizontal menu, e.g., main menu or status center: Swipe to the left or right on the operating display.

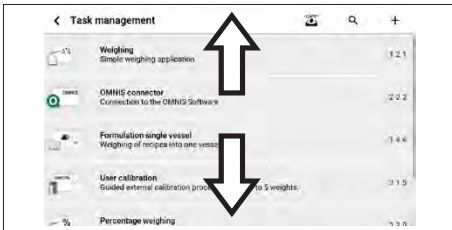

- ▶ To scroll through the lists in a vertical menu: Swipe the list downwards or upwards.



- ▶ If a value needs to be selected from a list:
 - ▶ Press the preferred value.
 - ▶ Confirm the selection with [OK].
- ▷ The selected value is saved and the list closes.

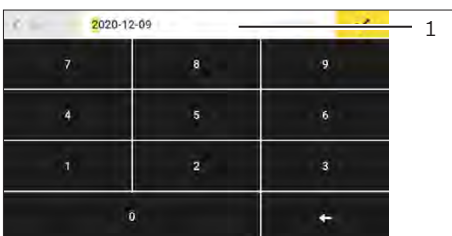

- ▶ If elements from a display need to be filtered or a display needs to be browsed:
 - ▶ Press the [Search] or [Filter] button.
- ▷ The keypad is displayed.
 - ▶ Type the search value or value to be filtered into the input field (1) using the keypad and confirm with [OK].
- ▶ To close the input field without searching or filtering: Leave the input field empty and press the [OK] button.

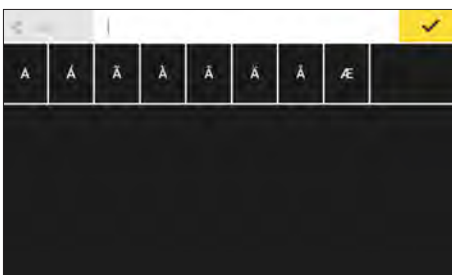

- ▶ If language-specific characters need to be entered using the keypad:
 - ▶ Press and hold a letter on the keypad.
 - ▷ If language-specific characters are available for the letter being pressed: The display containing the language-specific characters opens.
 - ▶ Press the required language-specific character.

5 Installation

5.1 Scope of Delivery

Item	Quantity
Device	1
Weighing pan	1
Power supply unit	1
Country-specific power supply cable	1 – 4*
In-use dust cover for the control unit	1
Operating Instructions	1 – 2*

* Quantity is country-specific.

5.2 Selecting an Installation Site

Procedure

- ▶ Ensure that the installation conditions have been met (see Chapter “15.3 Installation Conditions”, page 43).
- ▶ **NOTICE** Risk of damage to the power supply unit from argon! Observe the instructions for using argon (see Chapter “15.3.2 Ambient Conditions at the Installation Site”, page 44).

5.3 Unpacking

The control unit is installed on the device on delivery.

Procedure

- ▶ Unpack the device at the intended installation site.
- ▶ Lift the device with the polystyrene out of the packaging.
- ▶ Lift the polystyrene off the device.
- ▶ Place the device on its base.
- ▶ Sartorius recommends keeping the original packaging to return the device appropriately, e.g., for repairs.

5.4 Removing the Control Unit (Optional)

The control unit can be removed. This enables the flexible setup of the control unit at the workplace. If the control unit needs to be placed further away from the device, an extension cable can be used. The extension cord is available as an accessory (see Chapter "16.1 Accessories", page 53).

Tool: 1 Torx Allen key, T20

Material: 1 soft surface

Requirements

The weighing pan and all associated components are **not** placed on the device.

Procedure

- ▶ Turn over the device and place it on the soft surface.

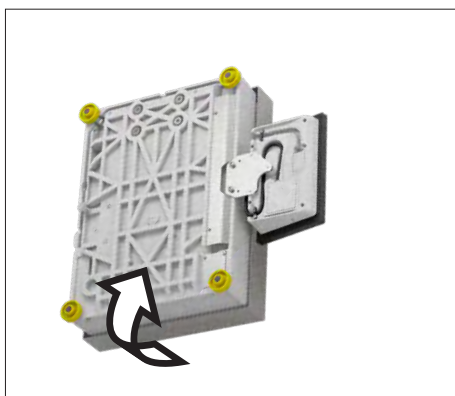

- ▶ To loosen the control unit's retainer: Use the Torx Allen key to remove both screws (1) from the thread (2).
- ▶ Remove the control unit and re-insert both screws into the threaded holes.

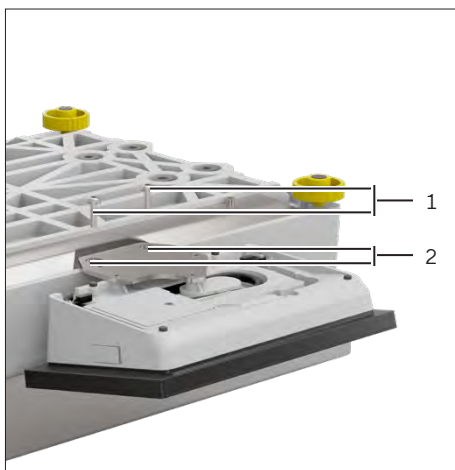

- ▶ Pull the connection cable between the control unit and the weighing module out of the control unit's retainer and unroll it.
- ▶ Turn the device over and place it on an even surface.

5.5 Preparing Below-balance Weighing (Optional)

The device can be configured for below-balance weighing. Samples can be suspended for weighing using below-balance weighing, e.g., samples, which do **not** fit on the weighing pan.

For below-balance weighing, the hook must be installed in the device base and the device set up on a weighing table with recess.

M

In legal metrology:

- The below-balance weighing equipment may **not** be used.
- The cover of the below-balance weighing equipment may **not** be opened.

Material: 1 hook for below-balance weighing, available as an accessory (69EA0040)
 1 soft surface
 1 draft protection shield
 1 weighing table with recess

Requirements

The weighing pan and all associated components are **not** placed on the device.

Procedure

- ▶ Turn over the device and place it on the soft surface.

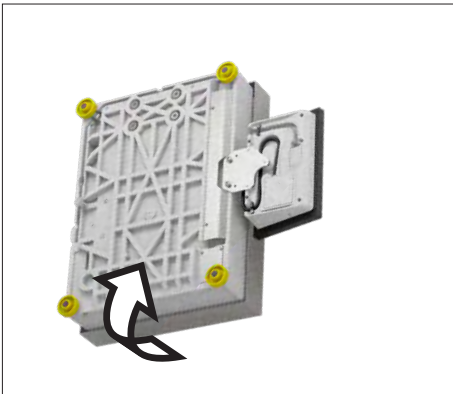

- ▶ Unscrew below-balance cap (1) at the device base with a suitable screwdriver.

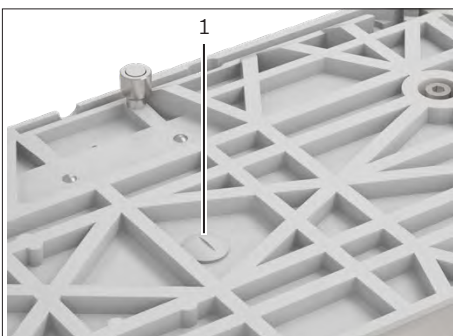

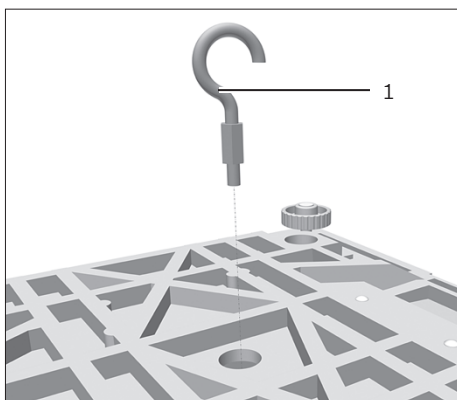

- ▶ **NOTICE** Damage to the device from cross-threading! Screw the hook for below-balance weighing (1) straight into the thread.

- ▶ Set up the device on the weighing table with recess. The hook for below-balance weighing may **not** touch the weighing table.
- ▶ Install the draft protection shield.

5.6 Positioning the Weighing Pan and Associated Components

Procedure

- ▶ Place the weighing pan on the weighing module.

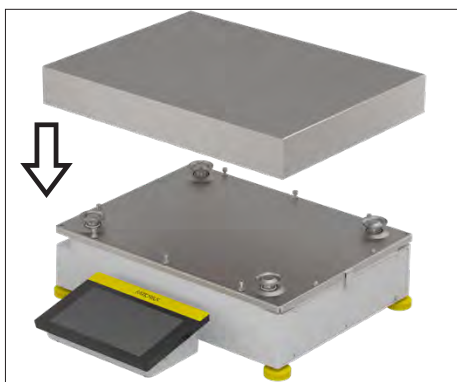

5.7 Acclimatizing

When a cold device is brought into a warm environment: The temperature difference can lead to condensation from humidity in the device (moisture formation). Moisture in the device can lead to malfunctions.

- ▶ Allow the device to acclimatize at the installation site (acclimatization duration see Chapter "15.4 Acclimatization Before Power Supply", page 44). The device must be disconnected from the power supply during that time.

6 Getting Started

Procedure

- ▶ **NOTICE** Improper connection may damage the device! If the device is connected to electronic components, e.g., printer, PC: The device must be disconnected from the power supply. Ensure that the device is disconnected from the power supply.
- ▶ Connect the device with the electronic components (see electronic components instructions).

6.1 Connecting the Ethernet Cable

Material: 1 Ethernet connection cable
1 soft surface

Requirements

The weighing pan and the associated components have **not** been set up.

Procedure

- ▶ If the control unit is attached to the weighing module: Turn over the device and place on the soft surface.
- ▶ If the control unit is removed from the weighing module: Turn over the control unit and place on a soft surface.
- ▶ Remove the cover (1) of the Ethernet connection on the underside of the control unit.
- ▶ Plug the Ethernet connection cable into the Ethernet connection.
- ▶ Place the device back on the device base on a level surface.

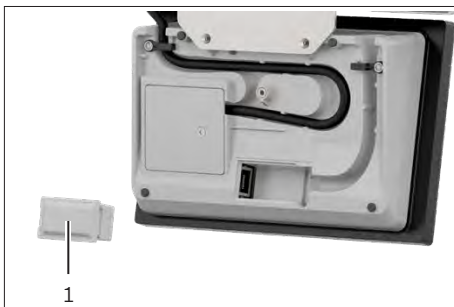

6.2 Installing the Power Supply Unit

Procedure

- ▶ Plug the DC supply cable of the AC adapter into the device's "Power supply" (1) connection and tighten the threaded fitting.

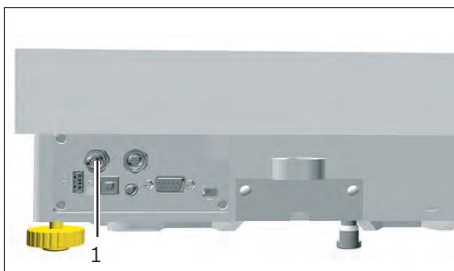

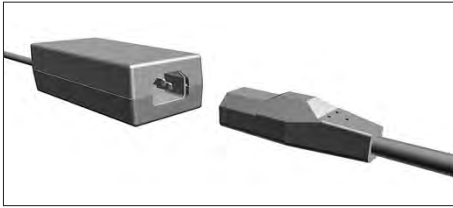

- ▶ Plug the power supply cable into the power supply unit connection.

6.3 Connecting the Power Supply

Requirements

The acclimatization time has been observed and the device has adjusted to room temperature (see Chapter 15.4, page 44).

Procedure

- ▶ Check whether the country-specific power plug matches the power supplies at the installation site.
 - ▶ If required: Contact Sartorius Service.
- ▶ **NOTICE** Damage to the device due to excessive input voltage! Check whether the voltage specifications on the power supply unit match those of the power supply at the installation site.
 - ▶ If the input voltage is too high or too low: Do **not** connect the device to the power supply.
 - ▶ Contact Sartorius Service.
- ▶ Connect the device to the power supply at the installation site. To do this, connect the power plug from the power supply cable into the power socket.
- ▶ The device is switched on and performs the initial functions for device startup.

6.4 Connecting Accessories

Accessories can be connected to the device.

Requirements

The accessories must be suitable for the device (see instructions for the accessories).

Procedure

- ▶ Ensure that the device is disconnected from the power supply.
 - ▶ If required: Disconnect the device from the power supply.
- ▶ Connect the accessories to the appropriate connections on the device (connections for accessory parts see instructions for accessories).
- ▶ Connect the device to the power supply.

6.5 Attaching Protective Caps and Covers

If connections of the device are **not** being used during operation: We recommend sealing the connections with the protective caps provided.

Procedure

- ▶ Check whether all unused connections have been sealed with a protective cap.
- ▶ If required: Seal the unused connections on the device (1) using the corresponding covers or protective caps.

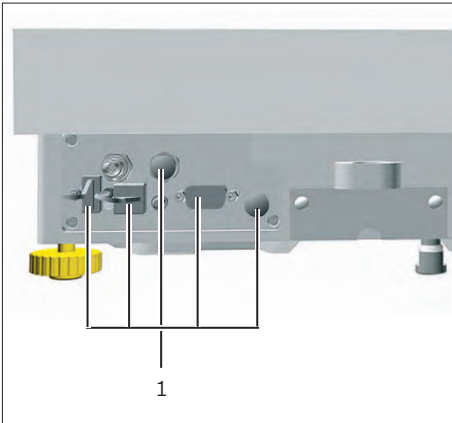

7 System Settings

7.1 Switching the Device On/Off and Activating Standby Mode

If the device is being connected to the power supply for the first time, or after restoring the factory settings: The device is switched on and the Setup Wizard opens. All steps in the Setup Wizard must be completed.

Requirements

The device is connected to the power supply.

Procedure

- ▶ NOTICE Pointed or sharp-edged objects may damage the operating display! Only touch the operating display with your fingertips.
- ▶ If the Setup Wizard is shown: Follow the instructions in the Setup Wizard in the operating display.
- ▶ If the login display is opened: Log into the device using a user profile.
- ▶ To activate standby mode: Press the [On | Off] button.
- ▷ The [Select standby mode] display is opened.
- ▶ Press the required standby mode.
- ▷ The device displays the time.
- ▶ To switch the device off: There are 2 options.
 - ▶ In the [Select standby mode] display, press the [SWITCH OFF DEVICE] button.
 - ▶ Disconnect the device from the power supply.
- ▶ To switch the device back on again from standby mode or after software-controlled switch-off: Press the on key on the back of the device.
- ▶ To switch the device back on again after disconnection from the power supply: Connect the device to the power supply.



7.2 User Login or Logout

The user selection is only displayed when at least one user is created.

Procedure

- ▶ Press the user selection (1).
- ▶ Select a user, e.g., Administrator.
- ▶ Press the [Login] button.
- ▷ If a password is assigned: The input screen for the password opens.
- ▶ Enter the password and confirm.
- ▶ To log out the active user profile from the device: Press the [Logout] button.
- ▶ If required: Log in a new user.

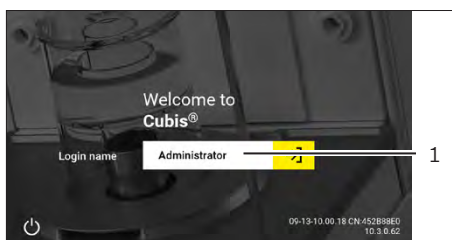

7.3 Performing System Settings

Default settings can be adjusted for the device and the applications in order to align with the ambient conditions and individual operating requirements.

The following settings are necessary to operate the device together with connected components:

- Set up the communication of the connected devices
- Set up additional components

The following settings are recommended to set up the device:

- Set the behavior of the isoCAL function.
- If the associated QAPP is activated and the LDAP server is configured:
Assign a password.

Procedure

- ▶ Open the main menu.
- ▶ Press the [Settings] button.
- ▶ To adjust settings: Open the preferred submenu.
- ▶ Select the preferred configuration value.
- ▶ Exit the menu.
- ▷ With some settings, the [Booting device] display is displayed in the operating display and the device restarts.

7.4 Using the Help Function

If help texts are available in a menu: The [Help] button is displayed.

Procedure



- ▶ Press the [Help] button.
- ▶ The help texts are displayed.
- ▶ To navigate through the help text: Swipe the text downwards or upwards.

7.5 Activating Applications (QAPPs) and Adding to a Task

7.5.1 Activating Applications

Some applications are activated for the device at the factory. Additional applications may be activated in the QAPP Center. These applications can be tested for 30 days free of charge, and after that require a license.

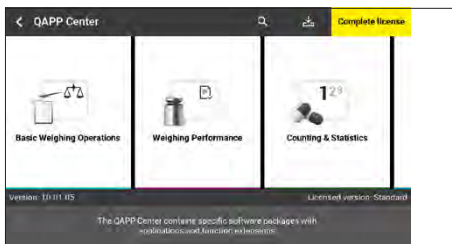

Procedure

- ▶ Open the task.
- ▶ Press the [QAPP Center] button.
- ▷ An overview of the available QAPP packages is displayed.
- ▶ Select the required QAPP package.
- ▷ A list of the applications contained in the QAPP package is displayed.
- ▶ If the selected QAPP package is to be approved with all the applications it contains:
 - ▶ Press the [License] button.
 - ▷ The input field for the license key is displayed.
 - ▶ If an additional cost is associated with the QAPP package: Enter the license key in the input field and press the [OK] button.
 - ▶ If no additional cost is associated with the QAPP package: Press the [OK] button.
- ▶ If an individual application from the displayed QAPP package is to be activated:
 - ▶ Press the preferred application.
 - ▷ A display opens containing details about the selected application.
 - ▶ Press the [License] button.
 - ▷ The input field for the license key is displayed.
 - ▶ If an additional cost is associated with the application: Enter the license key in the input field and press the [OK] button.
 - ▶ If no additional cost is associated with the application: Press the [OK] button.

7.5.2 Adding an Application to a Task

Applications must be added to a task so that they can run.

Procedure

- ▶ Open the task.
- ▶ Press the [New] button.
- ▷ A list of all activated applications is displayed.
- ▶ To select an application: Press the preferred application.
- ▷ The wizard for creating a new task starts.
- ▶ Follow the wizard's instructions in the operating display.

7.6 Switching Off the isoCAL Function

M

If the isoCAL function is switched off for a conformity-assessed device: The device can only be used in restricted temperature ranges for legal-for-trade applications (see Chapter "15.3.2 Ambient Conditions at the Installation Site", page 44). The isoCAL function **cannot** be switched off for all model versions.

Procedure

- ▶ In the "isoCal execution module" submenu, for the "isoCAL function" parameter, select the "Off" configuration value.

7.7 Adding Weighing and Print Profiles to a Task

To be able to use a weighing or print profile: Add a weighing or print profile to a task. Weighing and print profiles can be configured in the Settings menu.

Procedure

- ▶ Open the task.
- ▶ Create or edit a task. To do this, start the wizard to create or edit a task and follow the wizard's instructions in the operating display.

7.8 Downloading Additional Information

As part of the Cubis® IICUB firmware package on the Sartorius website, additional information is available for the device, e.g., a description of interface protocols, or a set of installation instructions for a website certificate. The information is available as a PDF file, partially in English. The information is stored on the MySartorius website. A Sartorius ID is required to be able to log into MySartorius and call up information. The Sartorius ID can be generated online.

Procedure

- ▶ Download the "Cubis® CUB Firmware" from the MySartorius website.
- ▶ Find the additional information you require, e.g., the description of interface protocols.

8 Operation

8.1 Leveling the Device

Leveling compensates any inclines at the device's installation site. If leveling is necessary: The [Leveling] button is displayed in the weighing display and a message is displayed in the status center.

Procedure

- ▶ If the weighing display is opened: Press the [Leveling] button.
- ▶ When the status center is displayed: Press the [Level] button.
- ▷ The Leveling Wizard opens.
- ▶ Follow the wizard's instructions.

8.2 Calibration, Adjustment or Linearization

Function	Description
Calibration	The device checks how much the displayed value deviated from the specified setpoint.
Adjustment	The device corrects the deviation to the setpoint.
Linearization	The device corrects the deviation from the ideal characteristic curve and the setpoint.

The device needs to be calibrated and adjusted regularly. Various methods can be selected for this:

- Adjusting with the isoCAL function
- Internal calibration and adjustment
- External adjustment
- Internal linearization

Only internal adjustment is described below.

M

External adjustment is **not** possible for conformity-assessed devices in legal metrology.

Procedure

- ▶ Where one of the following conditions occurs, calibrate and adjust the device using the preferred method:
 - Daily, every time the device is switched on
 - After every leveling
 - After changing the ambient conditions (temperature, humidity, or air pressure)
 - After setting the device up at a new installation site

8.2.1 Adjusting With the isoCAL Function

The device can be automatically internally calibrated and adjusted using the isoCAL function.

Requirements

- The isoCAL function is configured in the “Safe weighing” menu, e.g., “On, automatic execution”.
- The conditions for triggering and executing the isoCAL function are met (see Chapter “15.8 Conditions for isoCAL Function”, page 47).

Procedure

- ▶ If the isoCAL function is set to automatic start and the isoCAL function is triggered:
 - ▷ The [isoCAL] button flashes in the operating display.
 - ▶ Wait until the isoCAL function is executed.
 - ▷ In the operating display, a time display counts down from 15 seconds to 0.
 - ▷ If **no** load change or **no** operation takes place on the device before the expiration of the time display: The isoCAL function starts.
- ▶ If the isoCAL function is set to manual start and the isoCAL function is triggered:
 - ▷ The [isoCAL] button flashes in the operating display.
 - ▶ Press the [isoCAL] button.
 - ▷ The isoCAL function starts.
- ▷ If the isoCAL function is complete: The device confirms the completion of the calibration and adjustment process with an acoustic signal, and the calibration report is displayed.
- ▶ To output the calibration report via a connector: Press the [Print Memory] button.
- ▶ To close the calibration report and return to the previous display: Press the [OK] button.

8.2.2 Internally Calibrating and Adjusting the Device

Requirements

The weighing pan is unloaded.

Procedure

- ▶ Open the main menu.
- ▶ Press the “Internal adjustment” task.
- ▷ The internal calibration and adjustment function is executed.
- ▷ If automatic leveling is configured: The device levels itself automatically.
- ▷ If the calibration and adjustment function is complete: The device confirms the completion of the calibration and adjustment process with an acoustic signal, and the calibration report is displayed.
- ▶ To output the calibration report via a connector: Press the [Print Memory] button.
- ▶ To close the calibration report and return to the previous display: Press the [OK] button.

8.3 Preparing Weighings

The device must be prepared before every weighing.

Procedure

- ▶ Level the device.
- ▶ Zero the device. To do this, press the [Zero] button.
- ▶ If the device **cannot** be zeroed: Remove the sample to be weighed and re-zero the device.
- ▶ Adjust the device.

8.4 Weighing

When weighing chemicals, suitable vessels must be used for the material to be weighed. This makes it possible to prevent damage to the device or its accessories.

Requirements

The device is leveled and adjusted.

Procedure

- ▶ Start a task with weighing function.
- ▶ Zero the device. To do this, press the [Zero] button.
- ▶ If below-balance weighing is being carried out: Suspend the sample on the below-balance weighing hook, e.g., with a wire.
- ▶ If using a vessel for the sample:
 - ▶ Place the vessel for the material to be weighed onto the weighing pan.
 - ▶ Press the [Tare] button. This compensates for the weight of the vessel.
 - ▶ Tare the device. To do this, press the [Tare] button.
 - ▶ Place the sample in the vessel or fill the vessel.
- ▶ If **no** vessel is used for the sample: Place the sample on the weighing pan.
- ▶ Once the weight value is displayed in black and the weighing unit is displayed: Read off the measured value.

8.5 Running Application (Example)

8.5.1 Executing the “Unit change” Function

The “Unit change” function enables switching between the different units and resolutions defined in the weighing profile of the active task. The units and resolutions can be set at the beginning of the weighing process.

Procedure

- ▶ Start the preferred task.
- ▶ Press the [Unit change] button.
- ▷ All units defined in the weighing profile for the active task are displayed in a list.
- ▷ All resolutions for the weight value defined in the weighing profile for the active task are displayed in a list.
- ▶ Press the preferred unit.
- ▶ To set the resolution for the selected unit: Press the preferred resolution.
- ▶ To confirm the selection and return to the weighing display: Press the [OK] button.
- ▷ The current weight value is displayed in the selected unit and resolution.

9 Cleaning and Maintenance

9.1 Preparing the Device for Cleaning

Procedure

If the device is **not** to be cleaned with the Cleaning QAPP: Disconnect the device from the power supply.

- ▶ If an accessory is connected to the device: Disconnect the accessory from the device (see instructions for the accessory).
- ▶ Remove weighing pan and all associated components from the weighing module.

9.2 Cleaning the Device

Sartorius recommends cleaning the device at regular intervals, e.g., weekly. There must be **no** foreign substances, e.g., particles, fibers or liquids, in the area of the weighing pan.

To clean the device, you can use Sartorius cleaning utensils or a moistened cloth. The device can be cleaned with the help of the Cleaning QAPP. The Cleaning QAPP contains guided processes for normal and advanced device cleaning. The help texts in the Cleaning QAPP contain notes on valid cleaning agents and cleaning intervals (if cleaning intervals have been set).

Procedure

- ▶ **⚠ WARNING** Risk of injury due to electrical current! Protect the power supply unit and the power supply cable from liquids.
- ▶ Only use suitable cleaning agents and cleaning procedures and observe the product information for the cleaning agent used (cleaning agents see Chapter "15.13 Cleaning Agents and Cleaning Procedures", page 49).
- ▶ If the Cleaning QAPP is to be used for cleaning: Open the Cleaning QAPP for cleaning the device and follow the instructions in the operating display.

9.3 Recommissioning

Procedure

- ▶ Re-insert all components into the device (see Chapter 5.6, page 23).
- ▶ Connect the required accessories (see Chapter 6.4, page 25).
- ▶ If the device was disconnected from the power supply: Re-connect the device to the power supply (see Chapter 6.3, page 25).

9.4 Performing a Software Update

A software update can be installed (software package) from a USB mass storage device using one of the device's USB connections. An update can also be carried out from a server via other connectors of the device. The following describes the installation of a USB mass storage device, taken from the Sartorius website.

A software update can extend or change the functionality of the device. Sartorius recommends carrying out software updates:

- Prior to starting the software updates, save the device data to a USB mass storage device.
- If a QAPP Center update is to be carried out in addition: Perform the software update for the device first.

Two files are required for the software update: Firmware file with file ending ".upd", and checksum file with file ending ".upd.md5".

Execution of the software update and troubleshooting during this process are described in the help text "Device maintenance".

Requirements

- The device is connected to the power supply.
- The logged-in user has administrator rights.

Procedure

- ▶ Download the software package from the Sartorius website onto the USB mass storage device. To do this, download the "Cubis® III CUB Firmware" file.
- ▶ If this relates to a zip file: Unzip the software package on the USB mass storage device. The files must be saved in the main directory (at root level). The files must **not** be copied into a folder.
- ▶ Insert the USB mass storage device with the software package into the device's USB-A connection.
- ▶ In the "Settings" / "Device maintenance" menu, press the "Update firmware" menu entry.
- ▶ Press the "USB stick" as the connector and select the preferred software version.
- ▷ The software update takes approx. 3 minutes.
- ▷ Once the software update is complete: The software version number is updated in the login display.

9.5 Performing a QAPP Center Update

The QAPP Center package can be installed from a USB mass storage device using one of the device's USB connections. An update can also be carried out from a server via other connectors of the device. The following describes the installation of a USB mass storage device, taken from the Sartorius website.

Sartorius recommends the following when carrying out the QAPP Center update:

- Prior to starting the QAPP Center update, save the device data to a USB mass storage device.
- If a software update is also to be carried out: Perform the software update for the device first.

Two files are required for the QAPP Center update: QAPP Center with file ending “.appcenter”, and checksum file with file ending “qappcenter.upd.md5”.

Execution of the QAPP Center update and troubleshooting during this process are described in the help text “Device maintenance”.

Requirements

- The device is switched on.
- The QAPP Center package is saved on a USB mass storage device or on a server via a connector.

Procedure

- ▶ Download the QAPP Center package from the Sartorius website onto the USB mass storage device. To do this, download the “Cubis® III CUB Firmware” file.
- ▶ If this relates to a zip file: Unzip the QAPP Center package on the USB mass storage device. The files must be saved in the main directory (at root level). The files must **not** be copied into a folder.
- ▶ Insert the USB mass storage device with the QAPP Center package into one of the device’s USB-A connections.
- ▶ In the “Settings” / “Device maintenance” menu, press the “Install QAPP Center” menu entry.
- ▶ Press “USB stick” as the connector.
- ▶ Press the preferred package.
- ▶ Once the QAPP Center update is complete: Confirm successful installation with the [OK] button.
- ▷ Existing tasks remain unchanged after the QAPP Center update. In the existing tasks, the original QAPP versions are used.
- ▶ In order to use the new QAPP version: Create a new task with the new QAPP version. Existing tasks are **not** automatically adapted via the QAPP Center update.

10 Malfunctions

10.1 Warning Messages

Warning Message	Malfunction	Cause	Solution	Chapter, Page
Disp.Err.	The value to be output cannot be shown in the operating display.	The data to be displayed is not compatible with the set display format.	Adjust the display settings in the menu, e.g., resolution, unit, decimal places.	
High	The device is overloaded.	The device's maximum weighing capacity has been exceeded.	Reduce the applied weight to below the device's maximum weighing capacity.	15.7, 47
Low	The modulation of the weighing module's weighing converter is too low.	No weighing pan has been placed on the balance. A previously forgotten weight was removed after starting the device.	Insert the weighing pan into the device and switch the device off and on again.	
Com.Err.	The device is not receiving any weight values.	No communication exists between the control unit and the weighing module.	Wait until the control unit restores the communication with the weighing module. If the problem reoccurs: Contact Sartorius Service.	17, 55

10.2 Troubleshooting

Malfunction	Cause	Solution	Chapter, Page
The operating display is black.	The device is disconnected.	Check the connection to the power supply.	6.3, 25
	The power supply unit is not connected.	Connect the power supply cable to the power supply.	6.3, 25
An accessory device connected to the USB port is not working.	The connection to the device has been interrupted.	Switch the device off and on again.	
The operating display is red.	The connection to the device has been interrupted.	Switch the device off and on again.	
The displayed weight value changes constantly.	The device installation site is unstable.	Adjust the parameters in the "Ambient conditions" submenu.	
		Change the installation site.	5.2, 20
	A foreign object is positioned between the weighing pan and the housing.	Remove the foreign object.	
The weight readout displayed by the device is obviously wrong.	The device has not been adjusted.	Adjust the device.	8.2, 31
	The device was not tared before weighing.	Tare the device.	

10.3 Operating Issues

Malfunction	Cause	Solution	Chapter, Page
Password forgotten.	A user has forgotten the password.	Contact the administrator to delete or reset the password.	
	The administrator has forgotten the password.	Contact Sartorius Service to delete or reset the password.	17, 55

11 Decommissioning

11.1 Decommissioning the Device

Procedure

- ▶ Disconnect the device from the power supply. To do this, disconnect the power supply cable from the wall outlet.
- ▶ Disconnect all cables and accessories from the device connections.
- ▶ Place all caps and attachment hoods onto the corresponding connections.
- ▶ Clean the device (see Chapter 9.2, page 35).
- ▶ If below-balance weighing has been set up:
 - ▶ Turn over the device and place it on a soft surface.
 - ▶ Unscrew the hook for below-balance weighing from the thread.
 - ▶ Insert below-balance cap (1) back into the opening (2) in the device base and screw in with a suitable screwdriver.
 - ▶ Place the device on the device base on a level surface.

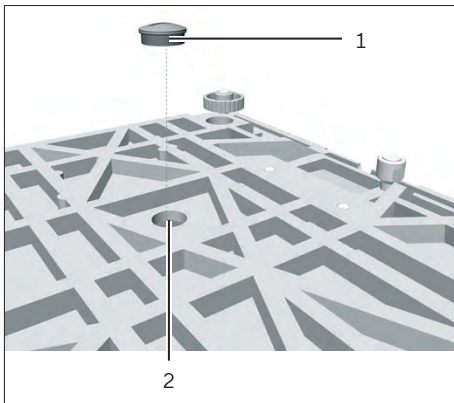

12 Transport

12.1 Transporting the Device

Procedure

- ▶ Disconnect the power supply cable from the power supply at the installation site.
- ▶ Only lift the device by its base.



- ▶ When lifting and transporting, ensure that **no** personnel or objects are in the way.
- ▶ Get help from others when lifting and transporting the device.
- ▶ Use suitable conveyance devices, e.g., trolleys, for long transport routes.

13 Storage and Shipping

13.1 Storing

Procedure

- ▶ Decommission the device.
- ▶ Store the device according to the ambient conditions (see Chapter “15.2 Ambient Conditions During Storage and Transport”, page 43).

13.2 Returning the Device and Parts

Defective devices or parts can be returned to Sartorius. Returned devices must be clean and packed in their original packaging.

Transport damage as well as measures for subsequent cleaning and disinfection of the device or parts by Sartorius shall be charged to sender.

Devices contaminated with hazardous materials, e.g., harmful biological or chemical substances, will **not** be accepted for repair or disposal.

Procedure

- ▶ Decommission the device.
- ▶ Contact Sartorius Service for instructions on how to return devices or parts.
- ▶ Pack the device and its parts in their original packaging for return.

14 Disposal

14.1 Disposing of the Device and Parts

The device and the device accessories must be disposed of properly by disposal facilities.

Two lithium cell batteries, type CR2032, are installed inside the device. Batteries must be disposed of properly by disposal facilities.

Many of the packaging materials are recyclable to promote sustainability and to contribute to reducing global waste volumes.

Procedure

- ▶ Dispose of the device in accordance with local government regulations. Inform the disposal facility that there are two lithium cell batteries, type CR2032, installed inside the device.
- ▶ Dispose of the packaging in accordance with local government regulations.

15 Technical Data

15.1 Dimensions and Weight

15.1.1 High-capacity Precision Balance

	Unit	Value
Dimensions (L × W × H)	mm	453 × 400 × 126
Weighing pan size	mm	400 × 300
Weight, approx.	kg	15.8

15.2 Ambient Conditions During Storage and Transport

	Unit	Value
Temperature		
During storage and transport	°C	-20 – +60
Storage, dry		

15.3 Installation Conditions

15.3.1 Installation Site

	Unit	Value
Height above sea level, maximum	m	3000
No potentially explosive atmospheres		
Laboratory room, with pollution level according to DIN EN 61010-1		2
Suitable for protection class		
Protection class of the device, according to EN 60529-1		IP54
Protection class of the power supply unit, according to DIN EN 60529		IP54
Access to operation-relevant parts is guaranteed		
Space requirements		
Suitable for the dimensions of the device and the associated components		
Setup surface		
[Stable, even]		
Suitable for the weight of the device and the associated components		

	Unit	Value
Additional properties		
No heat from heating systems or direct sunlight		
No direct drafts from open windows, AC systems, or doors		
No vibrations		
No "heavy traffic" areas (personnel)		
No electromagnetic fields or electromagnetic radiation, e.g., from radio equipment		
No dry air		

15.3.2 Ambient Conditions at the Installation Site

	Unit	Value
Temperature		
In operation	°C	+5 - +40
In operation, with isoCAL function, scope of application as per Directive 2014/31/EU	°C	+10 - +30
In operation, without isoCAL function, scope of application as per Directive 2014/31/EU	°C	+17 - +27
In operation, with conformity-assessed devices, as per specifications on the device ID label		
Relative humidity, in operation		
At temperatures up to 31°C, maximum	%	80
Decreasing linearly thereafter, maximum	%	50
Air pressure, minimum	mbar	600

15.4 Acclimatization Before Power Supply

	Unit	Value
Time period between unpacking and connecting to a power supply	h	2

15.5 Electrical Data

15.5.1 Power Supply

	Unit	Value
Power supply only permitted via the power supply cable and power supply unit supplied by Sartorius		
Sartorius power supply unit, type 1000099844		
Primary (power supply unit)		
AC voltage	V	100 - 240 ± 10%
Frequency	Hz	50 - 60
Current consumption, maximum	A	1.0
Power consumption, maximum	W	64.5
Secondary (device)		
DC voltage	V	14.25 - 15.75
Current consumption, maximum	A	2
Power consumption, maximum	W	30
Device fuses		
Quantity		1
Type: Electronic		
Power supply unit fuses		
Quantity		1
Type: Electronic		
Protection class, according to IEC 62368-1		
Device		1
Power supply unit		1
Overvoltage category according to IEC 61010-1		
Device		II
Power supply unit		II

15.5.2 Safety of Electrical Equipment

According to EN 61010-1 / IEC 61010-1 Safety requirements for electrical equipment for measurement, control, and laboratory use - Part 1: General requirements

15.5.3 Electromagnetic Compatibility

Suitable for use in industrial areas

Transient emissions

Class B; suitable for use in residential areas and areas that are directly connected to a low voltage network that (also) supplies residential buildings.

15.6 Interfaces

15.6.1 Specifications for the COM-RS232 Interface

Type of interface	Serial interface
Interface operation	Full duplex
Level	RS232
Connection	D-sub connector, 9-pin

Pin assignment

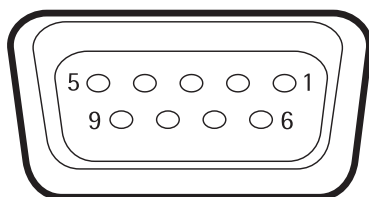

- Pin 1: **Not** assigned
- Pin 2: Data output (T × D)
- Pin 3: Data input (R × D)
- Pin 4: **Not** assigned
- Pin 5: Internal ground
- Pin 6: **Not** assigned
- Pin 7: Clear to Send (CTS)
- Pin 8: Request to Send (RTS)
- Pin 9: **Not** assigned

15.6.2 Specifications for the USB-A Interface

Communication:	USB host (Master)
Connectable devices	Sartorius printers, USB memory sticks, USB barcode scanners, USB keyboards, NFC readers

15.6.3 Specifications for the USB-B Interface

Communication	USB device (Slave)
Type of interface	Virtual serial interface (virtual COM-port, VCP) and “PC-Direct” communication

15.6.4 Specifications for the USB-C Interface

Communication	Downstream-facing port (DFP), USB host (Master)
Communication	RS232 connection with accessory YCC-USB-C-D09M

15.7 Recommended Calibration Weight

		CUB11201S...	CUB20201S...	CUB36200S...
	Unit	Value	Value	Value
External test weight	kg	10	20	30
Recommended accuracy class		F1	F1	F1

		CUB36201S...	CUB36201P...	CUB50201S...
	Unit	Value	Value	Value
External test weight	kg	30	30	50
Recommended accuracy class		F1	F1	F1

		CUB70200S...	CUB70201S...
	Unit	Value	Value
External test weight	kg	70	70
Recommended accuracy class		F1	F1

15.8 Conditions for isoCAL Function

		CUB50201S... CUB70200S... CUB70201S...	CUB11201S.. CUB20201S.. CUB36200S.. CUB36201S.. CUB36201P...
	Unit	Value	Value
Possible conditions for triggering the isoCAL function			
In the event of a temperature change	K	2	4
After a time interval	h	12	12
After successful leveling			
Only conformity-assessed devices: After interrupting the power supply			
Required conditions for executing the isoCAL function			
Operating display is in weighing mode (not in menu)			
Alphanumeric inputs are not active			
Min. time period without entry on the device	min	2	2
Min. time period with unchanged loading of the weighing pan	min	2	2
Max. loading of weighing pan, high-capacity	%	2	2

15.9 Data Storage Device

	Value
Maximum number of entities	500000

15.10 Integrated Clock

	Unit	Value
Maximum deviation per month (RTC)	s	30

15.11 Backup Battery

	Unit	Value
Lithium battery, type CR2032		
Service life at room temperature, minimum	Years	10

15.12 Materials

Housing:

Die-cast aluminum

Stainless steel 1.4401 | 1.4404

Control unit

Plastic PA12

Operating display: Plastic PA12 | float glass

Protective cap on connections: Plastic PA12

15.13 Cleaning Agents and Cleaning Procedures

15.13.1 Approved Cleaning Agents

Device components	Cleaning agents and concentration					
	Ethanol, 70%	Isopropanol, 70 %	Citric acid, 10 %	Diluted hy- drogen per- oxide, 3.5%	Sodium hy- droxide, 32%	Ecolab Klercide™ Sporicidal Chlorine Thiosulfate
Weighing pan	x	x	x	x	xx	x
Control unit	x	x	x	x	x	x
Device surfaces	x	xx	x	x	x	x

x Suitable

xx Suitable, may affect visual appearance of the device, does **not** impact mechanical stability

- **Not** suitable

15.13.2 Approved Cleaning Procedures

Wiping the device surfaces with a lightly moistened cleaning cloth

Spraying the device surfaces with cleaning agents, contact time Min 5–10

15.14 Metrological Data

15.14.1 Models CUB11201S | CUB20201S | CUB36200S

		CUB11201S...	CUB20201S...	CUB36200S...
	Unit	Value	Value	Value
Scale interval (d)	g	0.1	0.1	1
Maximum capacity (Max)	g	11200	20200	36200
Repeatability at 5 % load				
Standard deviation of the load values, tolerance	g	0.1	0.1	0.5
Standard deviation of the load values, typical value	g	0.02	0.02	0.2
Repeatability at approx. maximum capacity				
Standard deviation of the load values, tolerance	g	0.1	0.1	0.5
Standard deviation of the load values, typical value	g	0.02	0.02	0.2
Linearity deviation				
Tolerance	g	0.2	0.2	1
Typical value	g	0.06	0.06	0.2
Deviation when load is off-center, positions according to OIML R76				
Test weight	g	5000	5000	10000
Tolerance	g	0.3	0.3	1
Typical value	g	0.2	0.2	0.5
Sensitivity drift between +10 °C and +30 °C	ppm/K	2	2	3
Tare-maximum capacity: Less than 100 % of maximum capacity				
Accuracy class, according to Directive 2014/31/EU		II	II	II
Verification scale interval (e), according to Directive 2014/31/EU	g	1	1	1
Minimum load (Min), according to Directive 2014/31/EU	g	5	5	50
Minimum initial weight according to USP (United States Pharmacopeia), Chap. 41				
Optimum minimum initial weight	g	82	82	820
Typical minimum initial weight	g	82	82	820
Typical stabilization time	s	1.5	1.5	1
Typical measurement time	s	2	2	1.2

15.14.2 Models CUB36201S | CUB36201P | CUB50201S

		CUB36201S...	CUB36201P...	CUB50201S...
	Unit	Value	Value	Value
Scale interval (d)	g	0.1	0.1 1	0.1
Maximum capacity (Max)	g	36200	10200 36200	50200
Repeatability at 5 % load				
Standard deviation of the load values, tolerance	g	0.1	0.1	0.1
Standard deviation of the load values, typical value	g	0.02	0.02	0.04
Repeatability at approx. maximum capacity				
Standard deviation of the load values, tolerance	g	0.1	0.1	0.1
Standard deviation of the load values, typical value	g	0.02	0.02	0.04
Linearity deviation				
Tolerance	g	0.2	0.2	0.5
Typical value	g	0.1	0.1	0.15
Deviation when load is off-center, positions according to OIML R76				
Test weight	g	10000	10000	20000
Tolerance	g	0.3	0.3	0.5
Typical value	g	0.2	0.2	0.3
Sensitivity drift between +10 °C and +30 °C	ppm/K	2	2	2
Tare-maximum capacity: Less than 100 % of maximum capacity				
Accuracy class, according to Directive 2014/31/EU		II	II	II
Verification scale interval (e), according to Directive 2014/31/EU	g	1	1	1
Minimum load (Min), according to Directive 2014/31/EU	g	5	5	5
Minimum initial weight according to USP (United States Pharmacopeia), Chap. 41				
Optimum minimum initial weight	g	82	82	82
Typical minimum initial weight	g	82	82	82
Typical stabilization time	s	1.5	1.5	1.5
Typical measurement time	s	2	2	1.5

15.14.3 Models CUB70200S | CUB70201S

		CUB70200S...	CUB70201S...
	Unit	Value	Value
Scale interval (d)	g	1	0.1
Maximum capacity (Max)	g	70200	70200
Repeatability at 5 % load			
Standard deviation of the load values, tolerance	g	0.5	0.1
Standard deviation of the load values, typical value	g	0.2	0.04
Repeatability at approx. maximum capacity			
Standard deviation of the load values, tolerance	g	0.5	0.1
Standard deviation of the load values, typical value	g	0.2	0.04
Linearity deviation			
Tolerance	g	1	0.5
Typical value	g	0.2	0.15
Deviation when load is off-center, positions according to OIML R76			
Test weight	g	20000	20000
Tolerance	g	1	0.5
Typical value	g	0.6	0.3
Sensitivity drift between +10 °C and +30 °C	ppm/K	3	2
Tare-maximum capacity: Less than 100 % of maximum capacity			
Accuracy class, according to Directive 2014/31/EU		II	II
Verification scale interval (e), according to Directive 2014/31/EU	g	10	1
Minimum load (Min), according to Directive 2014/31/EU	g	50	5
Minimum initial weight according to USP (United States Pharmacopeia), Chap. 41			
Optimum minimum initial weight	g	820	82
Typical minimum initial weight	g	820	82
Typical stabilization time	s	1	1.5
Typical measurement time	s	1.2	1.5

16 Accessories

16.1 Accessories

This table contains a selection of the accessories that can be ordered. For information on other products, contact Sartorius.

16.1.1 Printers and Communication

Item	Quantity	Order Number
Thermal transfer direct thermal printer for GLP GMP printouts on continuous paper and tags	1	YDP30
Thermal transfer direct thermal network printer with Ethernet connection for GLP GMP printouts on continuous paper and tags	1	YDP30-NET
Printer paper and thermal transfer ribbon, 90 m	1	69Y03285
Self-adhesive paper and thermal transfer ribbon, 90 m	1	69Y03286
Thermal paper, 24 m	5	69Y03287
Self-adhesive thermal paper, 24 m	5	69Y03288
Tag roll, 58 x 30 mm	1000	69Y03092
Tag roll, 58 x 76 mm	500	69Y03093
Tag roll, 58 x 100 mm	350	69Y03094
Wireless nano USB adapter for company network or independent Wi-Fi network, e.g., operation with a Sartorius network printer YDP30-NET (only for Europe)	1	YWLAN01MS
Wireless nano router, e.g., for Sartorius network printer YDP30-NET for operation in an independent Wi-Fi network (only for Europe)	1	YWLAN02MS
Display cable, 3 m, for separate installation of display and weighing modules, installation by Sartorius Service or at the factory	1	YCC01-CUB-2
Installation of display cable, 3 m, for separate installation of display and weighing modules	1	VF4016
USB cable, 3 m, for connecting USB B port to USB A port	1	69MS0099
RS232C connection cable, 9-pin, 3 m, for connection to a PC with 9-pin COM interface	1	VF4761
USB QR barcode scanner	1	YBR05
Foot switch for printing, taring, or using function keys, selection via menu, incl. T connector	1	YFS01
USB-RFID reader	1	YRFID01
Motion sensor for triggering a maximum of 4 functions via gesture control, selection via menu	1	YHS02USB

16.1.2 Filter Balance and Antistatic Accessories

Item	Quantity	Order Number
Ionizer with universal adapter	1	YIB03-C

16.1.3 Special Applications

Item	Quantity	Order Number
Display holder for CUB models with resolution 10/100 mg	1	YDH03CUB
Cleaning kit	1	YCK01MC

16.1.4 Weighing Tables

Item	Quantity	Order Number
Weighing table		
Made from synthetic stone, with vibration dampening	1	YWT03
Made from wood and synthetic stone	1	YWT09
Wall console	1	YWT04

16.1.5 Weighing Accessories

Item	Quantity	Order Number
Weighing scoop made from chrome-nickel steel, L 90 mm × W 32 mm × H 8 mm	1	641214
Stand for raising the control unit	1	YDH04CUB
Hook for below-balance weighing for precision weighing modules with scale intervals of 100 mg 1 g and weighing capacity > 20 kg, not suitable for conformity-assessed devices	1	69EA0040

17 Sartorius Service

Sartorius Service is available for queries regarding the device. Visit the Sartorius website for information about the service addresses, services provided, or to contact a local representative.

For inquiries about the system or when contacting Sartorius Service in the event of a malfunction, keep the device information close at hand, e.g., serial number, hardware, firmware, configuration, to pass it on to Sartorius Service. To do this, refer to the information on the manufacturer's ID label and in the "General device Information" menu.

18 Trademark Information

Ecolab Klercide™ is a registered trademark of Ecolab Europe GmbH.

19 Conformity

19.1 EU Declaration of Conformity

The attached Declaration of Conformity hereby confirms compliance of the device with the directives cited.

M

The Declaration of Conformity supplied with the balance is for conformity-assessed (verified) balances for use in the EEA. Keep it in a safe place.