

## Operating Instructions | Mode d'emploi | Instrucciones de manejo

Original Operating Instructions | Mode d'emploi original | Traducción de las instrucciones de manejo originales

# Cubis®

Models CUB: Precision balances

Modèles CUB: Balances de précision

Modelos CUB: Balanzas de precisión



# SARTORIUS

imLab



[www.imlab.eu](http://www.imlab.eu) - [info@imlab.eu](mailto:info@imlab.eu)



+33(0)3 20 55 19 11



+32(0)16 73 55 72

# Contents

<b>1</b>	<b>About These Instructions</b> .....	<b>6</b>
1.1	Validity .....	6
1.2	Related Documents .....	6
1.3	Target Groups .....	6
1.4	Symbols Used .....	7
1.4.1	Warnings in Operation Descriptions .....	7
1.4.2	Other Symbols Used .....	7
<b>2</b>	<b>Safety Instructions</b> .....	<b>8</b>
2.1	Intended Use .....	8
2.1.1	Modifications to the Device .....	8
2.1.2	Repairs to the Device .....	8
2.2	Qualifications of Personnel .....	9
2.3	Functionality of the Device Parts .....	9
2.4	Safety Information on the Device .....	9
2.5	Electrical Equipment .....	9
2.5.1	Power Supply Unit and Power Supply Cable .....	9
2.5.2	Connection Point for Power Supply Unit and Power Supply Cable .....	9
2.6	Conduct in an Emergency .....	10
2.7	Accessories .....	10
2.8	Risk of Injury During Transporting .....	10
2.9	Trip Hazard from Connection Cables .....	10
<b>3</b>	<b>Device Description</b> .....	<b>11</b>
3.1	Device Overview .....	11
3.2	Weighing Pan and Associated Components .....	12
3.3	Connections and Components .....	13
3.3.1	Connections to the Weighing Module .....	13
3.3.2	Connections to the Control Unit .....	14
3.4	Conformity-assessed Devices .....	15
3.5	Accessories .....	15
3.6	Below-balance Weighing .....	15
<b>4</b>	<b>Operating Design</b> .....	<b>16</b>
4.1	Operating Elements in the Main Menu .....	16
4.2	Operating Elements in Task Management .....	17
4.3	Status Center .....	18
4.4	User Management .....	19
4.4.1	User Profiles .....	19
4.4.2	User Login .....	19
4.5	Weighing and Print Profiles .....	19
4.6	Applications and Tasks .....	19
4.7	Navigating the Menus .....	19
<b>5</b>	<b>Installation</b> .....	<b>21</b>
5.1	Scope of Delivery .....	21
5.2	Selecting an Installation Site .....	21
5.3	Unpacking .....	21
5.4	Turning Over and Installing Device .....	22

5.5	Attaching or Removing the Operating Display.....	22
5.6	Preparing Below-balance Weighing .....	23
5.7	Positioning the Weighing Pan and Associated Components .....	24
5.8	Installing the Control Unit .....	25
5.9	Acclimatizing.....	25
<b>6</b>	<b>Getting Started .....</b>	<b>26</b>
6.1	Connecting the Ethernet Cable .....	26
6.2	Installing the Power Supply Unit .....	26
6.3	Connecting the Power Supply .....	27
6.4	Connecting Accessories .....	27
6.5	Attaching Protective Caps and Covers .....	27
<b>7</b>	<b>System Settings.....</b>	<b>28</b>
7.1	Switching the Device On/Off and Activating Standby Mode .....	28
7.2	User Login or Logout .....	28
7.3	Performing System Settings .....	29
7.4	Using the Help Function .....	29
7.5	Activating Applications (QAPPs) and Adding to a Task .....	29
7.5.1	Activating Applications.....	29
7.5.2	Adding an Application to a Task .....	30
7.6	Switching Off the isoCAL Function .....	30
7.7	Adding Weighing and Print Profiles to a Task .....	31
7.8	Downloading Additional Information .....	31
7.9	Observing Warm-up Time .....	31
<b>8</b>	<b>Operation .....</b>	<b>32</b>
8.1	Leveling the Device .....	32
8.2	Calibration and Adjustment.....	32
8.2.1	Adjusting With the isoCAL Function .....	33
8.2.2	Internally Calibrating and Adjusting the Device .....	33
8.3	Preparing Weighings.....	34
8.4	Weighing.....	34
8.5	Running Application (Example).....	34
8.5.1	Executing the "Unit change" Function .....	34
<b>9</b>	<b>Cleaning and Maintenance.....</b>	<b>36</b>
9.1	Preparing the Device for Cleaning .....	36
9.2	Cleaning the Device .....	36
9.3	Recommissioning .....	36
9.4	Performing a Software Update.....	37
9.5	Performing a QAPP Center Update.....	37
<b>10</b>	<b>Malfunctions .....</b>	<b>39</b>
10.1	Warning Messages.....	39
10.2	Troubleshooting .....	40
10.3	Operating Issues.....	40
<b>11</b>	<b>Decommissioning .....</b>	<b>41</b>
11.1	Decommissioning the Device.....	41
<b>12</b>	<b>Transport.....</b>	<b>41</b>
12.1	Transporting the Device.....	41

<b>13 Storage and Shipping</b> .....	<b>42</b>
13.1 Storing .....	42
13.2 Returning the Device and Parts .....	42
<b>14 Disposal</b> .....	<b>43</b>
14.1 Disposing of the Device and Parts .....	43
<b>15 Technical Data</b> .....	<b>44</b>
15.1 Dimensions and Weights .....	44
15.2 Ambient Conditions During Storage and Transport .....	44
15.3 Installation Conditions .....	45
15.3.1 Installation Site .....	45
15.3.2 Ambient Conditions at the Installation Site .....	45
15.3.3 Ambient Temperature for the isoCAL Function .....	46
15.4 Acclimatization Before Power Supply .....	46
15.5 Electrical Data .....	47
15.5.1 Power Supply .....	47
15.5.2 Safety of Electrical Equipment .....	47
15.5.3 Electromagnetic Compatibility .....	48
15.6 Warm-up Time to Reach Operating Temperature .....	48
15.7 Interfaces .....	49
15.7.1 COM-RS232 Interface .....	49
15.7.2 Specifications for the USB-A Interface .....	49
15.7.3 Specifications for the USB-B Interface .....	49
15.8 Data Storage Device .....	50
15.9 Integrated Clock .....	50
15.10 Backup Battery .....	50
15.11 isoCAL Function .....	50
15.11.1 Models CUB14202S   CUB10202S .....	50
15.11.2 Models CUB8202S   CUB6202S   CUB6202P   CUB4202S   CUB2202S   CUB1202S .....	50
15.11.3 Models CUB12201S   CUB8201S   CUB5201S .....	51
15.12 Recommended Adjustment Weight .....	51
15.13 Materials .....	51
15.14 Cleaning Agents and Cleaning Procedures .....	52
15.14.1 Approved Cleaning Agents .....	52
15.14.2 Approved Cleaning Procedures .....	52
15.15 Metrological Data .....	53
15.15.1 Models CUB14202S   CUB10202S   CUB8202S .....	53
15.15.2 Models CUB6202S   CUB6202P   CUB4202S   CUB2202S .....	54
15.15.3 Models CUB1202S   CUB12201S   CUB8201S   CUB5201S .....	55
<b>16 Accessories</b> .....	<b>56</b>
16.1 Accessories .....	56
<b>17 Sartorius Service</b> .....	<b>58</b>
<b>18 Trademark Information</b> .....	<b>58</b>
<b>19 Conformity</b> .....	<b>58</b>
19.1 EU Declaration of Conformity .....	58

# 1 About These Instructions

## 1.1 Validity

These instructions are part of the device; they must be read in full and kept in a safe place. These instructions apply to the device in the following versions:

Device	Model
Cubis® precision balance	CUB10202S   CUB1202S   CUB12201S   CUB14202S   CUB2202S   CUB4202S   CUB5201S   CUB6202P   CUB6202S   CUB8201S   CUB8202S

## 1.2 Related Documents

- ▶ In addition to these instructions, observe the following documents:
  - Instructions for accessories used, e.g., printers or weighing pans
  - Optional: Additional information about cleaning the device (Best Cleaning Practices for Cubis® II Ultra-High Resolution Balances)

## 1.3 Target Groups

These instructions are addressed to the following target groups. The target groups must possess the specified knowledge.

Target Group	Knowledge and Qualifications
Operator	The operator is familiar with the device and the associated work processes. The operator understands the hazards which may arise when working with the device and knows how to prevent them.*

\* If a person in the target group operates the software interface of the device, they are also the “user”.

## 1.4 Symbols Used

### 1.4.1 Warnings in Operation Descriptions

---

#### **DANGER**

Denotes an immediate hazard that will result in death or serious injury if it is **not** avoided.

---

#### **WARNING**

Denotes a hazard that may result in death or serious injury if it is **not** avoided.

---

#### **CAUTION**

Denotes a hazard that may result in moderate or minor injury if it is **not** avoided.

---

#### **NOTICE**

Denotes a hazard that may result in property damage if it is **not** avoided.

---

### 1.4.2 Other Symbols Used

- ▶ Required action: Describes activities that must be carried out. The activities in the sequence must be carried out in succession.
- ▷ Result: Describes the result of the activities carried out.
- [ ] Refers to operating and display elements. Indicates status, warning, and error messages.
- M Indicates information for legal metrology for conformity-assessed (verified) devices. Conformity-assessed devices are also referred to as “verified” in these instructions.

#### **Figures in these instructions**

Depending on the device configuration, the figures depicting the device and operating display may differ slightly from the supplied device. The variants shown in these instructions are examples.

## 2 Safety Instructions

### 2.1 Intended Use

The device is a high-resolution balance, which can be used in laboratories. The device is intended to accurately determine the mass of materials in liquid, paste, powder, or solid form.

Appropriate vessels must be used for loading certain materials.

The device can be operated as follows:

- In individual operation
- Connected to a PC
- Integrated into a network

The device is intended solely for use in accordance with these instructions. Any other use is considered **improper** and can impair the protection supported by the device, e.g., protection against mechanical dangers.

#### Foreseeable misuse

The following applications are **not** permitted: Operation under any atmosphere other than the normal atmosphere.

#### Operating conditions for the device

Do **not** use the device in potentially explosive environments. Only use the device indoors.

Do **not** use the device in a vacuum or negative pressure environment (maximum air pressure see Chapter "15.3.2 Ambient Conditions at the Installation Site", page 45).

Do **not** use physical measures to alter the as-delivered state of the device, and only connect approved accessories (see Chapter "16 Accessories", page 56).

The device may only be used with the equipment and under the operating conditions described in the Technical Data section of these instructions.

#### 2.1.1 Modifications to the Device

If the device is modified, e.g., by attaching extra components: Persons may be put at risk. Device-specific documents and product approvals may lose their validity.

For questions regarding modifications, contact Sartorius.

#### 2.1.2 Repairs to the Device

Device repairs may only be carried out by persons with specialized knowledge of the device. If the device is **not** repaired by a specialist: Persons may be put at risk. Device-specific documents and product approvals may lose their validity.

Sartorius recommends that any repair work, even that carried out after the end of the warranty period, is carried out by Sartorius Service or after consulting with Sartorius Service.

## 2.2 Qualifications of Personnel

Persons who do not possess adequate knowledge about how to use the device may injure themselves and other persons.

If a particular qualification is required for an activity: The target group is specified. If **no** qualification is specified: The activity can be performed by the "Operator" target group.

## 2.3 Functionality of the Device Parts

**Non**-functioning device parts, e.g., as a result of damage or wear, can cause malfunctions. There is a risk of injury to persons.

- ▶ If device parts are **not** functioning: Do **not** use the device.
- ▶ Observe the maintenance intervals.

## 2.4 Safety Information on the Device

Symbols, e.g., warnings and safety stickers, are safety information for handling the device. Missing or illegible safety information may result in this information **not** being observed. There is a risk of injury to persons.

- ▶ Do **not** conceal, remove, or modify the symbols.
- ▶ Replace the symbols if they become illegible.

## 2.5 Electrical Equipment

### 2.5.1 Power Supply Unit and Power Supply Cable

The use of an **unauthorized** power supply unit or power supply cable may cause life-threatening injuries as a result of electric shocks, for example.

- ▶ Only use the original power supply unit and power supply cable.
- ▶ If the power supply unit or power supply cable needs to be replaced: Contact Sartorius Service. Do **not** repair or modify the power supply unit or power supply cable.

### 2.5.2 Connection Point for Power Supply Unit and Power Supply Cable

If the connection point for the power supply unit and power supply cable is not suitable: There is a risk of severe injury, e.g., due to electric shocks.

- ▶ Protect the power supply unit and the power supply cable from liquids.
- ▶ Do not use a damaged power supply unit or power supply cable.

## 2.6 Conduct in an Emergency

If an emergency occurs, e.g., due to malfunctions of the device or dangerous situations: Persons may be injured. The device must be immediately taken out of operation:

- ▶ Disconnect the device from the power supply.
- ▶ Prevent the device from recommissioning.

## 2.7 Accessories

The use of unsuitable accessories can affect the functionality and operating reliability of the device and has the following consequences:

- Risk of injury to persons
  - Damage, malfunctions, or failure of the device
- ▶ Only use accessories that have been approved by Sartorius for this device.

## 2.8 Risk of Injury During Transporting

If the device is **not** transported correctly: The device could fall and cause an injury, e.g., a foot injury. If the device is **not** placed down correctly, e.g., on a laboratory table: Fingers may be crushed.

- ▶ Disconnect the device from all connections at the installation site.
- ▶ Use both hands when transporting the device and setting it down. To do this, reach sideways under the device with both hands in the rear part of the device.
- ▶ Do **not** carry the device on the draft shield or the control unit.

## 2.9 Trip Hazard from Connection Cables

If the device's connection cables, e.g., the power supply cable, are laid haphazardly: People may trip over the connection cables and injure themselves.

- ▶ Lay all connection cables in such a way that trip hazards are avoided.

## 3 Device Description

### 3.1 Device Overview

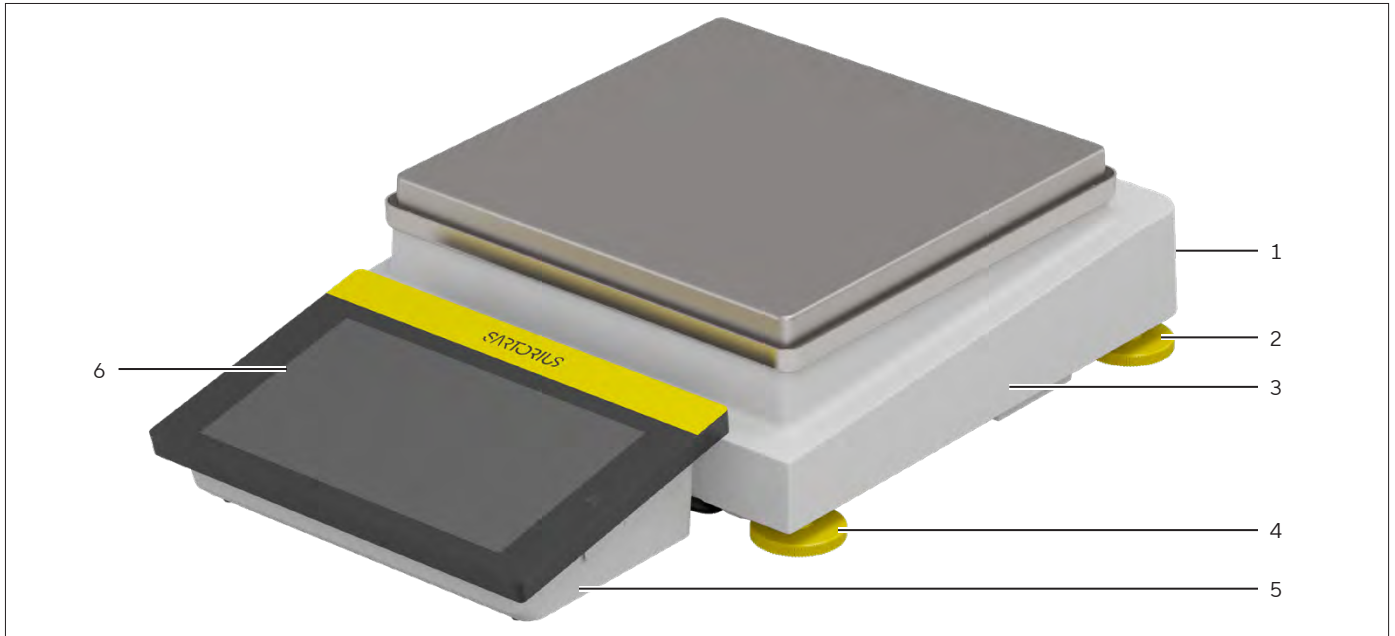

Fig. 1: Cubis® precision balance (example)

Pos.	Name	Description
1	Manufacturer's ID label	<ul style="list-style-type: none"> <li>– Contains additional information about the device, e.g., serial number and the metrological and technical data.</li> <li>– <b>Not</b> depicted.</li> </ul>
2	Support foot	Only models CUB10202S   CUB12201S   CUB14202S, <b>not</b> adjustable, is screwed in to level the device.
3	Weighing module	
4	Leveling foot	Motorized or manually adjustable.
5	Control unit	Removable.
6	Operating display	Intended to operate the software

## 3.2 Weighing Pan and Associated Components

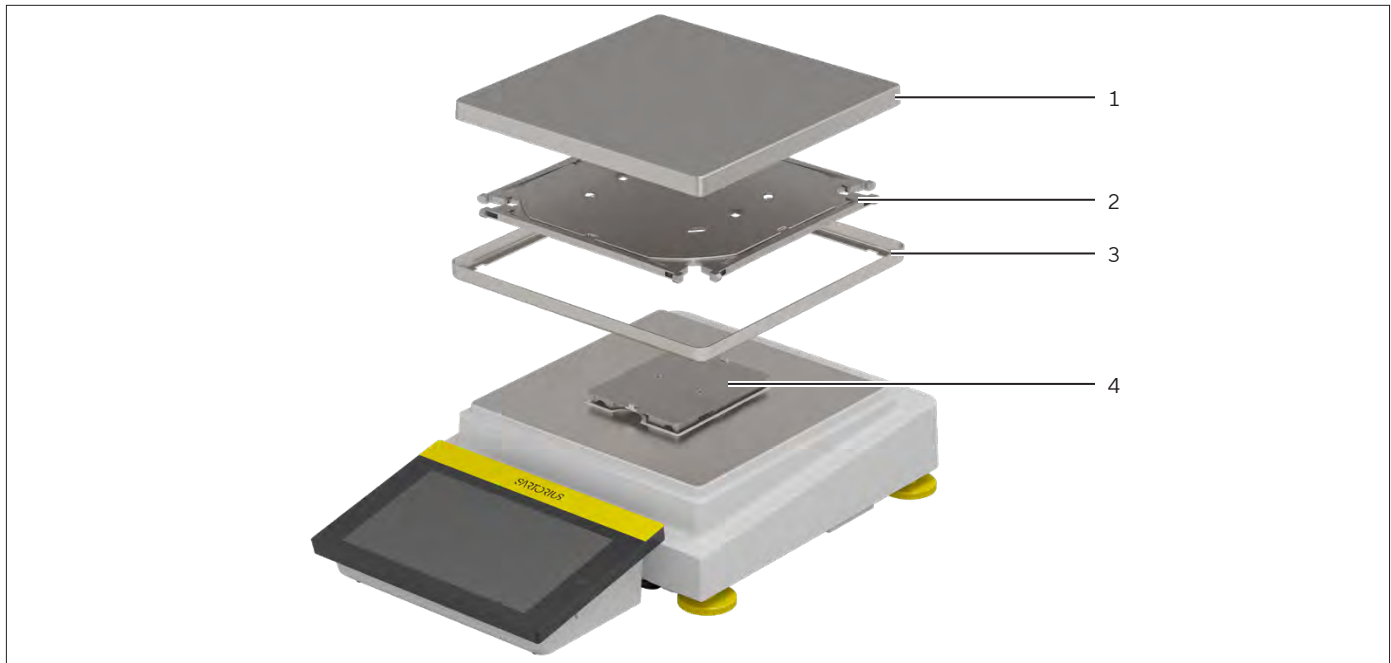

Fig. 2: Components of the weighing module (example)

Pos.	Name
1	Weighing pan
2	Pan support
3	Shield disk
4	Pan retainer

## 3.3 Connections and Components

### 3.3.1 Connections to the Weighing Module

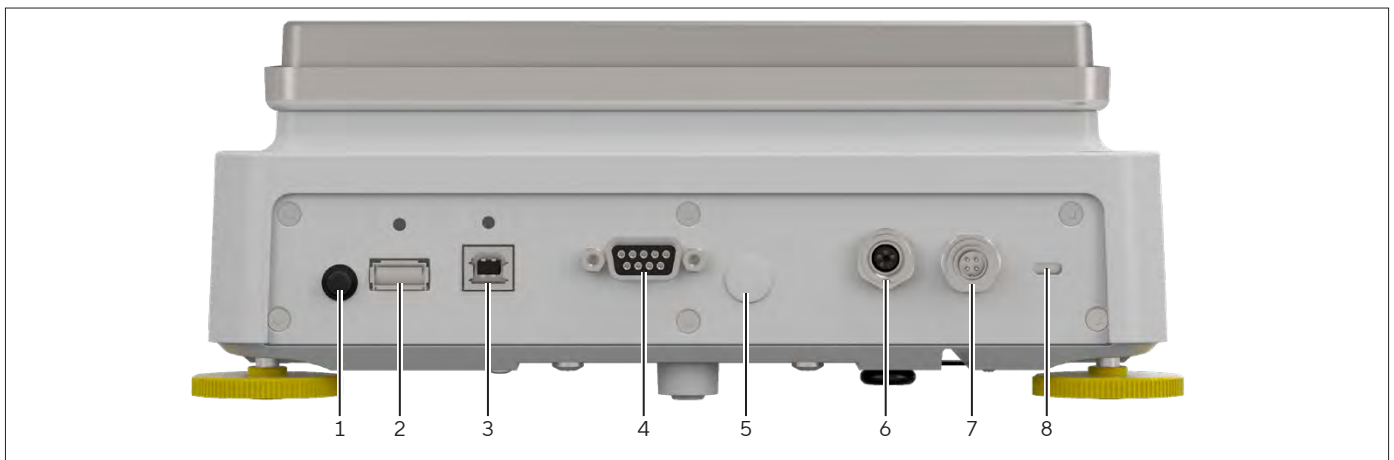

Fig. 3: Connections and components on the back of the device (example)

Pos.	Name	Description
1	On key	
2	USB-A connection	<ul style="list-style-type: none"> <li>– For USB accessories, e.g., printers, USB mass storage devices, barcode scanners.</li> <li>– Sealed with a plastic protective cap.</li> <li>– The protective cap is secured to the device.</li> </ul>
3	USB-B connection	<ul style="list-style-type: none"> <li>– For connection to a PC.</li> <li>– Sealed with a plastic protective cap.</li> <li>– The protective cap is secured to the device.</li> </ul>
4	COM-RS232 connection	<ul style="list-style-type: none"> <li>– 9-pin, for connection to a PC or PLC.</li> <li>– Sealed with a plastic protective cap.</li> <li>– The protective cap is removable.</li> </ul>
5	Access switch	<ul style="list-style-type: none"> <li>– Protects the device from changes to the device settings.</li> <li>– Is sealed for conformity-assessed devices.</li> <li>– Sealed with a plastic protective cap.</li> <li>– The protective cap is removable.</li> </ul>
6	Peripheral connection	<ul style="list-style-type: none"> <li>– For connecting accessories.</li> <li>– Sealed with a plastic protective cap.</li> <li>– The protective cap is removable.</li> </ul>
7	Power supply	For connection to the power supply.
8	Slot	For connecting a “Kensington” anti-theft device.

### 3.3.2 Connections to the Control Unit

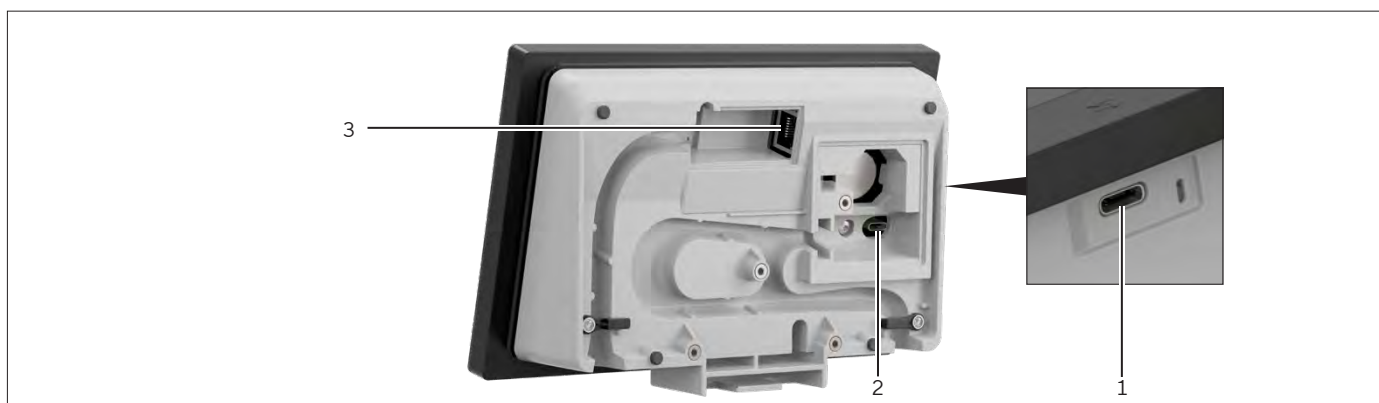

Fig. 4: Connections to control unit, cover removed

Pos.	Name	Description
1	USB-C connection	<ul style="list-style-type: none"> <li>– For connecting accessories.</li> <li>– Sealed with a plastic protective cap.</li> <li>– The protective cap is secured to the device.</li> </ul>
2	Weighing module connection	<ul style="list-style-type: none"> <li>– For the device connection cable.</li> <li>– Sealed with a plastic cover.</li> <li>– The cover is screwed on.</li> </ul>
3	Ethernet connection	<ul style="list-style-type: none"> <li>– For connection to a network.</li> <li>– Sealed with a plastic cover.</li> <li>– The cover is removable.</li> </ul>

## 3.4 Conformity-assessed Devices

Some settings of conformity-assessed models are protected against operator changes, e.g., “external adjustment”. This measure is intended to ensure the suitability of the devices for use in legal metrology.

## 3.5 Accessories

Accessories are available for the device. These enable the device to be customized to the specific conditions during weighing procedures, e.g. weighing scoops or weighing tables.

## 3.6 Below-balance Weighing

The device is suitable for below-balance weighing. Samples can be suspended for weighing using below-balance weighing, e.g., samples, which do not fit on the weighing pan. Below-balance weighing is possible under the following conditions:

- The device must be set up on a weighing table with recess.
- For below-balance weighing, a below-balance weighing hook must be inserted in the device base (see Chapter “16.1 Accessories”, page 56).

**M**

In legal metrology:

- The below-balance weighing equipment may not be used.
- The cover of the below-balance weighing may not be removed.

## 4 Operating Design

### 4.1 Operating Elements in the Main Menu

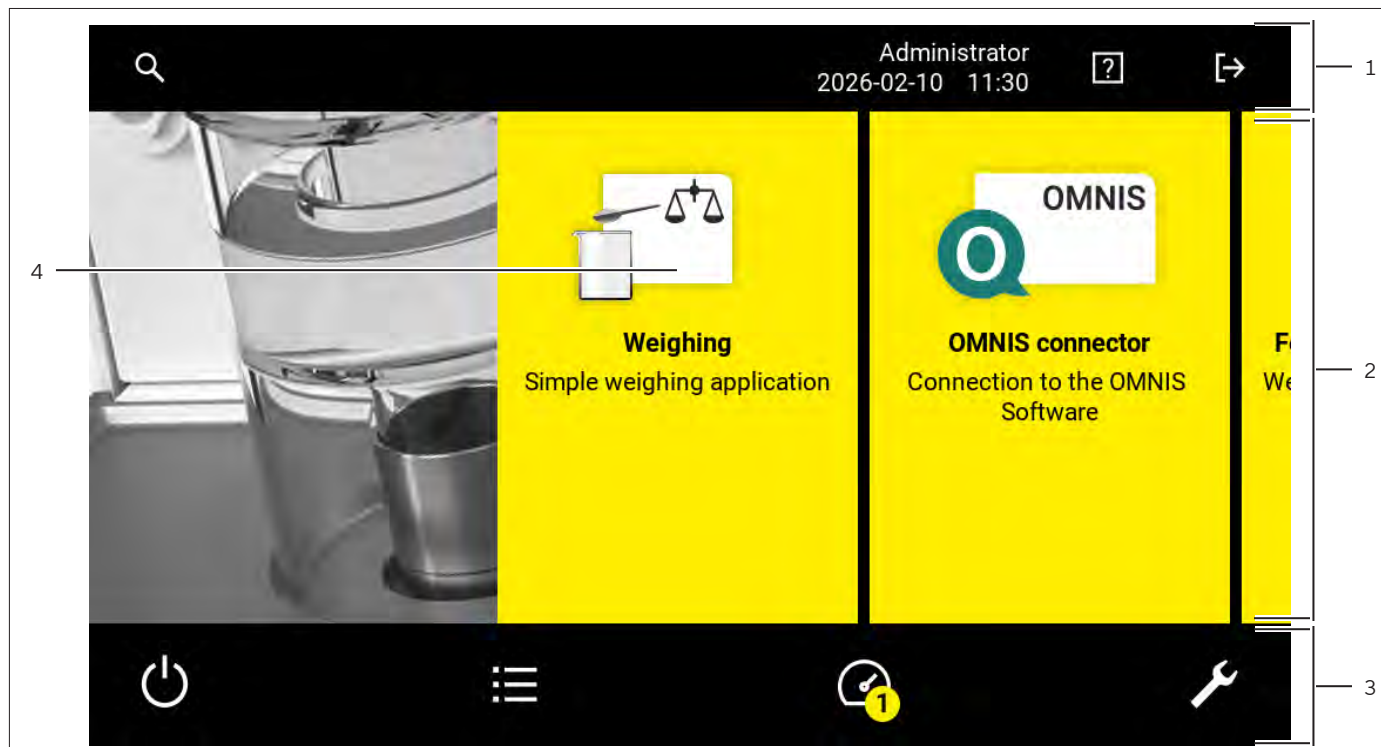

Fig. 5: Operating elements in the main menu (example)

Pos.	Name	Description
1.	Navigation and function bar	<ul style="list-style-type: none"> <li>– Enables navigation and searching in menus and lists.</li> <li>– In the “Settings” menu: Displays the name of the menu.</li> </ul>
2.	Available tasks	Displays all tasks available for the active user.
3.	Function bar	Displays available submenus and operating functions for the current display and current user.
4.	Task	Starts the described task.

## 4.2 Operating Elements in Task Management

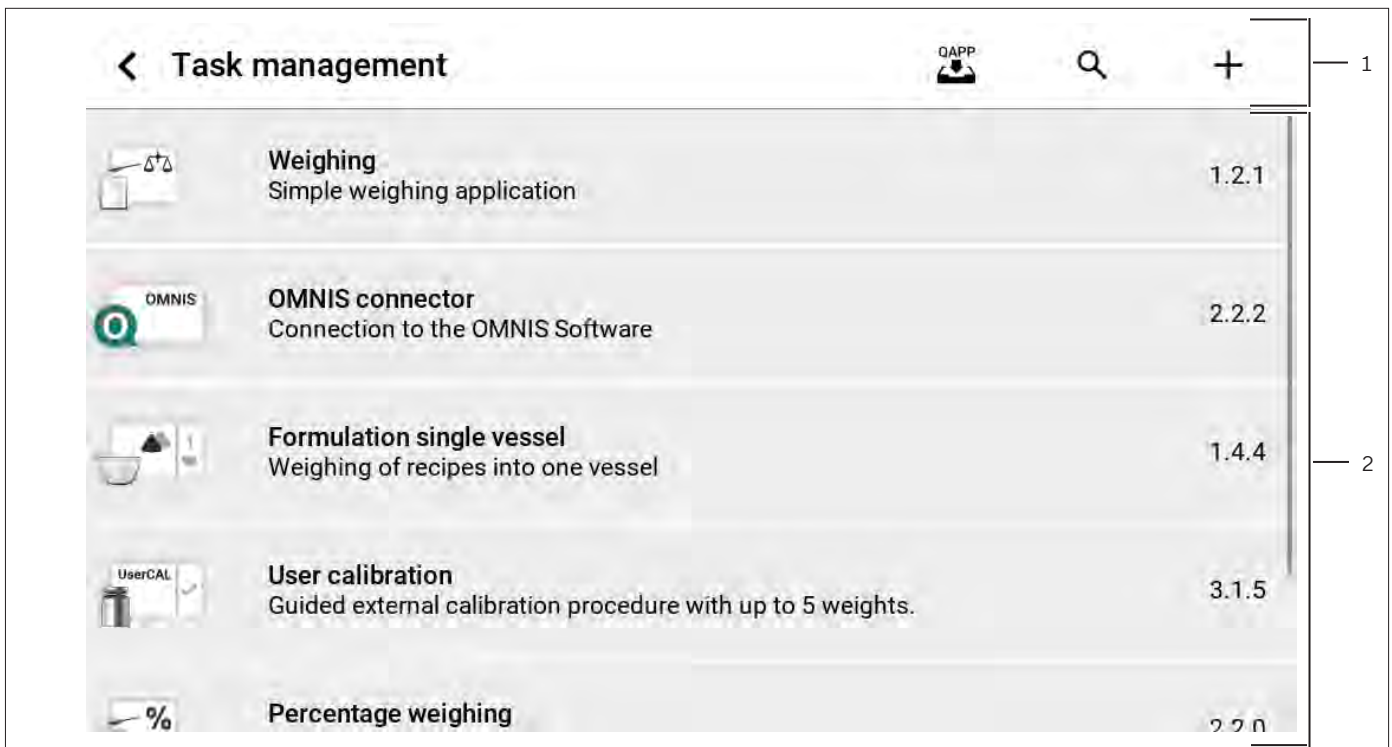

Fig. 6: Operating elements in task management (example)

Pos.	Name	Description
1.	Navigation and function bar	<ul style="list-style-type: none"> <li>– Enables navigation and searching in menus and lists.</li> <li>– Enables the addition of tasks.</li> <li>– Opens the QAPP Center.</li> <li>– Displays the name of the menu.</li> </ul>
2.	Available tasks	<ul style="list-style-type: none"> <li>– Displays all available tasks.</li> <li>– Opens a summary of the properties for the displayed task.</li> </ul>

## 4.3 Status Center

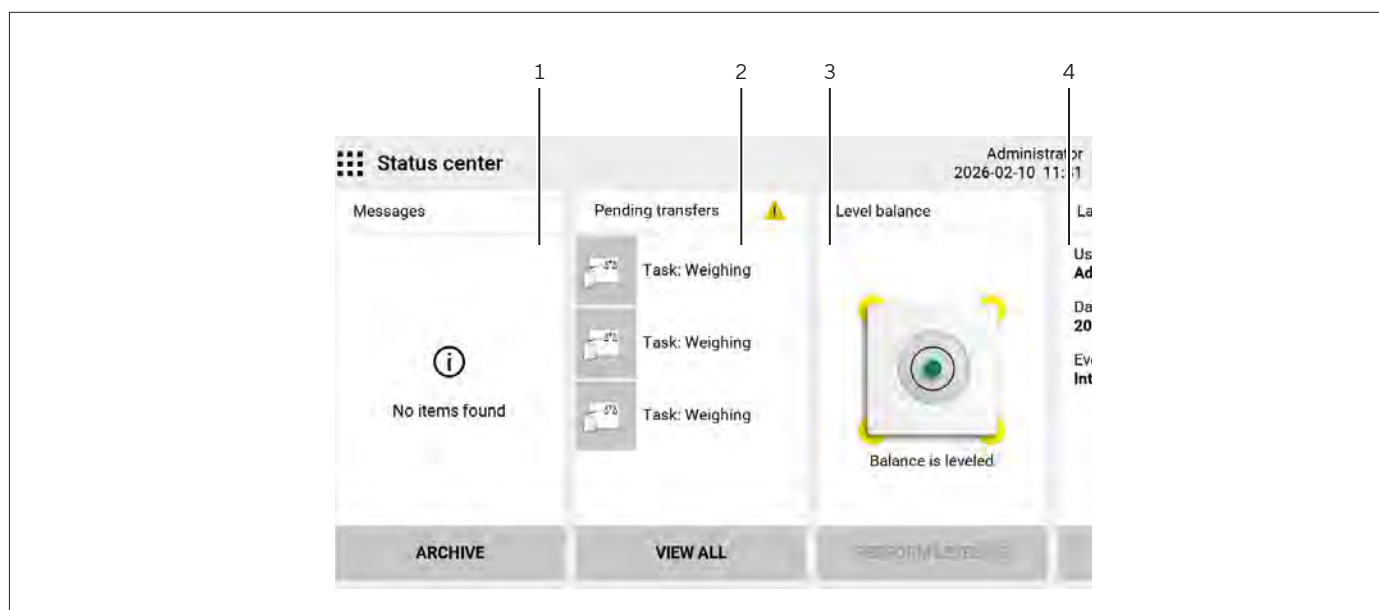

Fig. 7: Status center (example)

Pos.	Name	Description
1	Messages	Displays information, warning, and error messages.
2.	Pending transfer	If there are pending transfers: Displays the pending transfers for completed tasks.
3.	Leveling status	Displays the status of the level, starts leveling.
4.	Further categories	Displays further categories that are made visible when swiping to the left, e.g., <ul style="list-style-type: none"> <li>– Status for the device</li> <li>– Calibration and adjustment report</li> <li>– Audit trail</li> </ul>

## 4.4 User Management

### 4.4.1 User Profiles

In the factory, four user profiles are created for the device. One role is assigned to each user profile. Each role has rights to operate the device. The rights assigned to each role depend on which device functions the user has to use. User profiles can be adapted.

Additional user profiles, roles, and rights may be activated in the device settings for devices with licensed user management.

### 4.4.2 User Login

The user must log in to the login display with a user profile. Various setting options and tasks are displayed in the operating display depending on the user profile and role.

## 4.5 Weighing and Print Profiles

Weighing and print profiles can be created. These profiles can be assigned to a task.

Preset profiles can be used in a task. The preset profiles can be adjusted individually to the application and saved in new profiles for weighing and printing.

## 4.6 Applications and Tasks

Applications (QAPP applications) are grouped together in QAPP packages. Depending on the model, the device can be supplied with some freely accessible applications. These applications can be used to carry out the most important functions.

Subsequent licensing (package QP99) covers all other applications and can be activated in the QAPP Center for a fee.

An application must be configured as a task before it can be used. Specific settings need to be applied for this, with the help of the assistant function. Tasks are visible to all users who have the required role to perform the task.

## 4.7 Navigating the Menus

### Procedure

- ▶ To open an application or a menu from the main menu:
- ▶ Press the application button or required menu button in the function bar.
- ▷ The application or menu is opened and the name of the open menu is opened in the navigation bar.
- ▶ To return to the main menu from other displays: Press the [Back] or [Menu] button.



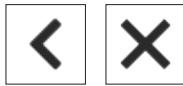

- ▶ To return to the next higher menu level: Press the [Back] or [Cancel] button.



- ▶ To scroll through the available tasks or categories in a horizontal menu, e.g., main menu or status center: Swipe to the left or right on the operating display.

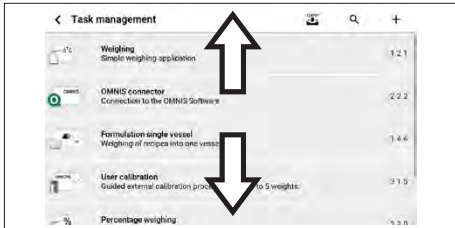

- ▶ To scroll through the lists in a vertical menu: Swipe the list downwards or upwards.



- ▶ If a value needs to be selected from a list:
  - ▶ Press the preferred value.
  - ▶ Confirm the selection with [OK].
- ▶ The selected value is saved and the list closes.

- ▶ If elements from a display need to be filtered or a display needs to be browsed:
  - ▶ Press the [Search] or [Filter] button.

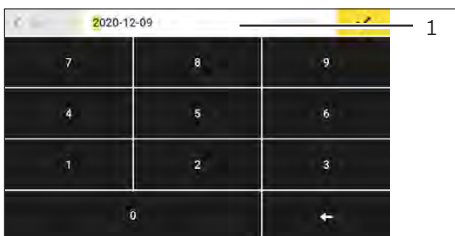

- ▶ The keypad is displayed.
  - ▶ Type the search value or value to be filtered into the input field (1) using the keypad and confirm with [OK].
- ▶ To close the input field without searching or filtering: Leave the input field empty and press the [OK] button.

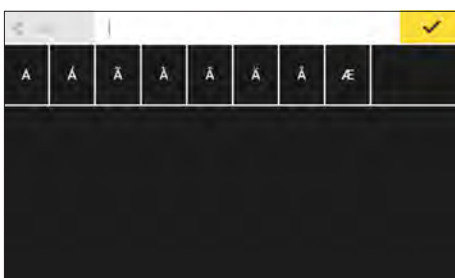

- ▶ If language-specific characters need to be entered using the keypad:
  - ▶ Press and hold a letter on the keypad.
  - ▶ If language-specific characters are available for the letter being pressed: The display containing the language-specific characters opens.
  - ▶ Press the required language-specific character.

## 5 Installation

### 5.1 Scope of Delivery

Item	Quantity
Device	1
Weighing pan	1
Shield disk (only models CUB14202S   CUB10202S   CUB8202S   CUB6202S   CUB6202P   CUB4202S   CUB2202S   CUB1202S)	1
Pan support	1
Power supply unit	1
Country-specific power supply cable	1 – 4*
USB connection cable	1
In-use dust cover for the control unit	1
In-use dust cover for the weighing module	1
Operating Instructions	1 – 2*

\* Quantity is country-specific

### 5.2 Selecting an Installation Site

#### Procedure

- ▶ Ensure that the installation conditions have been met (see Chapter “15.3 Installation Conditions”, page 45).
- ▶ **NOTICE** Risk of damage to the power supply unit from argon! Observe the instructions for using argon (see Chapter “15.3 Installation Conditions”, page 45).

### 5.3 Unpacking

The device is packed in foam packaging. The individual layers of the packaging must be removed one after the other.

#### Procedure

- ▶ Lift the device with the foam padding out of the packaging.
- ▶ Place the device in the foam padding on its side.
- ▶ Lift the foam padding off the device.
- ▶ Place the device on its base.
- ▶ Keep all parts of the original packaging, e.g., to return the device.

## 5.4 Turning Over and Installing Device

For some installation work, the device has to be turned over, for example when inserting connection cables.

Material: 1 soft support base, for placing down the device

### Requirements

There are **no** components installed in the pan retainer.

---

### **⚠ CAUTION**

#### Risk of injury when lifting or transporting!

- ▶ Use both hands when transporting the device and setting it down. To do this, reach sideways under the device with both hands in the rear part of the device.
- 

### Procedure

- ▶ If the device needs to be turned over:
  - ▶ Reach sideways under the device with both hands in the rear part of the device.
  - ▶ Turn over the device and place on a soft surface.

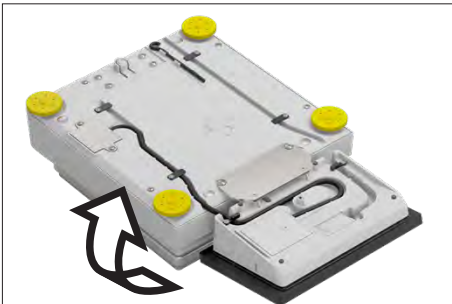

- ▶ If the device is to be returned to the upright position:
  - ▶ Reach sideways under the device with both hands in the rear part of the device.
  - ▶ Place the device back onto its base.

## 5.5 Attaching or Removing the Operating Display

The control unit can be removed. This enables the flexible setup of the control unit at the workplace.

Tool: 1 Torx Allen key, T20

Material: 1 soft surface

### Requirements

There are **no** components installed in the pan retainer.

### Procedure

- ▶ Turn over the device and place on a soft surface.

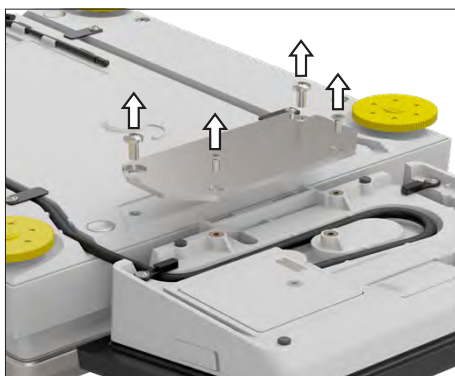

- ▶ To loosen the control unit's retainer: Use the Torx Allen key to remove the four screws.
- ▶ Remove the retaining plate.
- ▶ Remove the control unit.
- ▶ Lift off the retaining plate and the screws and store in a safe place.

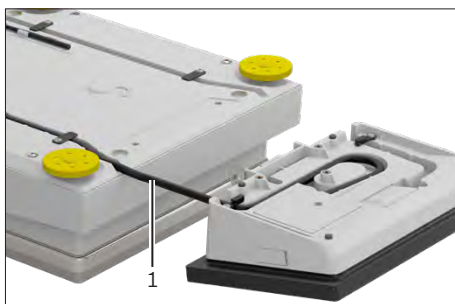

- ▶ Pull the connection cable (1) between the control unit and the weighing module out of the control unit's retainer and unroll it.

- ▶ Turn the device over again and place it on an even surface.

## 5.6 Preparing Below-balance Weighing

The device can be configured for below-balance weighing. Samples can be suspended for weighing using below-balance weighing, e.g., samples, which do **not** fit on the weighing pan.

For below-balance weighing, the hook must be installed in the device base and the device set up on a weighing table with recess.

- Material:
- 1 soft surface
  - 1 draft protection shield
  - 1 weighing table with recess

### Requirements

The weighing pan and the associated components have **not** been set up.

### Procedure

- ▶ Turn over the device and place it on a soft surface.

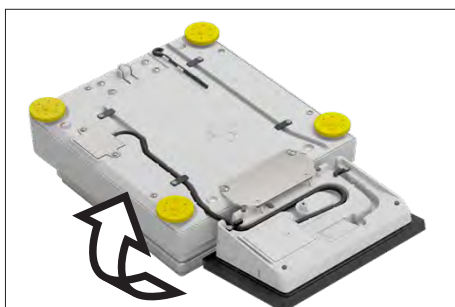

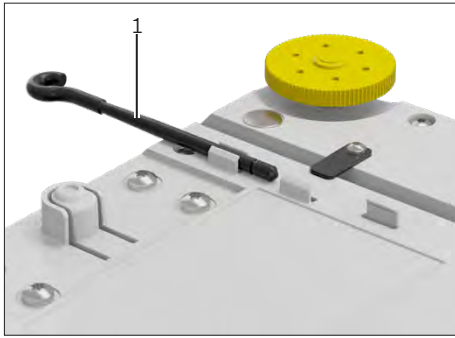

- ▶ Remove the below-balance weighing hook (1) from the retainer on the underside of the base of the device.

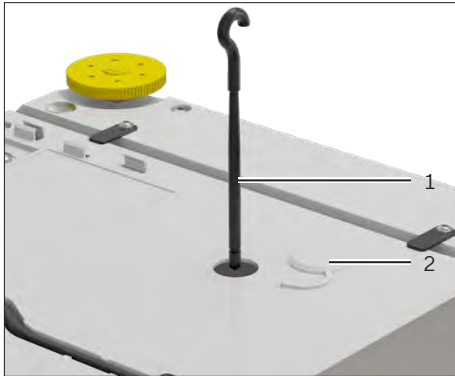

- ▶ Pull out the cover (2) of the below-balance weighing equipment.
- ▶ **NOTICE** Damage to the device from cross-threading! Only screw the below-balance weighing hook (1) straight into the thread opening.

- ▶ Set up the device on the weighing table with recess. The below-balance weighing hook may **not** touch the weighing table.
- ▶ Install a draft protection shield.
- ▶ Suspend the sample on the below-balance weighing hook, e.g. with a wire.

## 5.7 Positioning the Weighing Pan and Associated Components

### Procedure

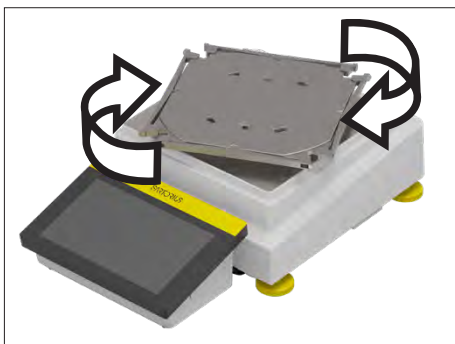

- ▶ Place the pan support down on the pan retainer, diagonally to the weighing module, and apply gentle pressure.
- ▶ Carefully turn the pan support clockwise until the two buttons engage.
- ▶ The pan support is now attached.

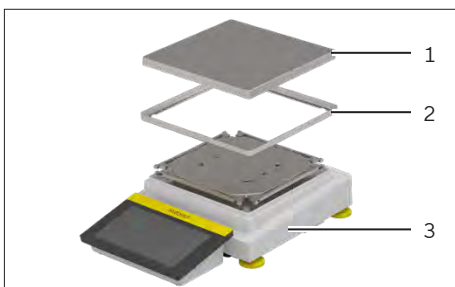

- ▶ Place the shield disk (2) on the weighing module (3).
- ▶ Place the weighing pan (1) on the pan support.

## 5.8 Installing the Control Unit

The control unit can be installed in front of or next to the device.

### Procedure

- ▶ Remove the control unit from the device (see Chapter “5.5 Attaching or Removing the Operating Display”, page 22).
- ▶ Place the control unit in the preferred position (for the dimensions for positioning the control unit, see Chapter “15.1 Dimensions and Weights”, page 44). The control unit must be positioned entirely on the base.

## 5.9 Acclimatizing

When a cold device is brought into a warm environment: The temperature difference can lead to condensation from humidity in the device (moisture formation). Moisture in the device can lead to malfunctions.

### Procedure

- ▶ Allow the device to acclimatize at the installation site (acclimatization duration see Chapter “15.4 Acclimatization Before Power Supply”, page 46). The device must be disconnected from the power supply during that time.

## 6 Getting Started

### 6.1 Connecting the Ethernet Cable

Material: 1 Ethernet connection cable  
1 soft surface

#### Requirements

The weighing pan and the associated components have **not** been set up.

#### Procedure

- ▶ If the control unit is attached to the weighing module: Turn over the device and place on the soft surface.
- ▶ If the control unit is removed from the weighing module: Turn over the control unit and place on a soft surface.
- ▶ Open the cable lock (3).
- ▶ Remove the cover (1) of the Ethernet connection on the underside of the operating display.
- ▶ Plug the Ethernet cable into the Ethernet connection.
- ▶ Place the Ethernet cable into the cable channel (2) and turn the cable lock (3) using the Ethernet cable.
- ▶ Insert the cover (1) of the Ethernet connection on the underside of the operating display.
- ▶ If the control unit is attached to the weighing module: Place the device back on the device base on a level surface.
- ▶ If the control unit is removed from the weighing module: Place the control unit back on a level surface.

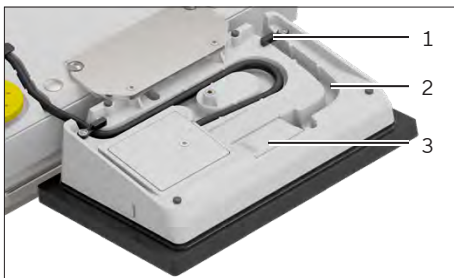

### 6.2 Installing the Power Supply Unit

#### Procedure

- ▶ Connect the connection cable from the power supply unit to the "Power supply" connection on the back of the device.
- ▶ Plug the power supply cable into the power supply unit connection.

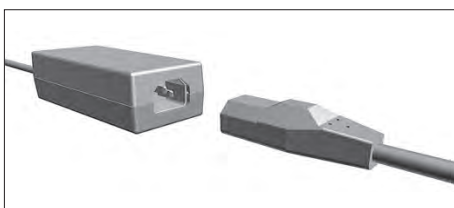

## 6.3 Connecting the Power Supply

### Requirements

The acclimatization time has been observed and the device has adjusted to room temperature (see Chapter 15.4, page 46).

### Procedure

- ▶ Check whether the country-specific power plug matches the power supplies at the installation site.
  - ▶ If required: Contact Sartorius Service.
- ▶ **NOTICE** Damage to the device due to excessive input voltage! Check whether the voltage specifications on the power supply unit match those of the power supply at the installation site.
  - ▶ If the input voltage is too high or too low: Do **not** connect the device to the power supply.
  - ▶ Contact Sartorius Service.
- ▶ Connect the device to the power supply at the installation site. To do this, connect the power plug from the power supply cable into the power socket.
- ▷ The device is switched on and performs the initial functions for device startup.

## 6.4 Connecting Accessories

Accessories can be connected to the device.

### Requirements

The accessories must be suitable for the device (see instructions for the accessories).

### Procedure

- ▶ Ensure that the device is disconnected from the power supply.
  - ▶ If required: Disconnect the device from the power supply.
- ▶ Connect the accessories to the appropriate connections on the device (connections for accessory parts see instructions for accessories).
- ▶ Connect the device to the power supply.

## 6.5 Attaching Protective Caps and Covers

If connections of the device are **not** being used during operation: We recommend sealing the connections with the protective caps provided.

### Procedure

- ▶ Check whether all unused connections have been sealed with a protective cap.
  - ▶ If required: Seal the unused connections on the device (1) using the corresponding covers or protective caps.

## 7 System Settings

### 7.1 Switching the Device On/Off and Activating Standby Mode

If the device is being connected to the power supply for the first time, or after restoring the factory settings: The device is switched on and the Setup Wizard opens. All steps in the Setup Wizard must be completed.

#### Requirements

The device is connected to the power supply.

#### Procedure

- ▶ **NOTICE** Pointed or sharp-edged objects may damage the operating display! Only touch the operating display with your fingertips.
- ▶ If the Setup Wizard is shown: Follow the instructions in the Setup Wizard in the operating display.
- ▶ If the login display is opened: Log into the device using a user profile.
- ▶ To activate standby mode: Press the [On | Off] button.
- ▷ The [Select standby mode] display is opened.
- ▶ Press the required standby mode.
- ▷ The device displays the time.
- ▶ To switch the device off: There are 2 options.
  - ▶ In the [Select standby mode] display, press the [SWITCH OFF DEVICE] button.
  - ▶ Disconnect the device from the power supply.
- ▶ To switch the device back on again from standby mode or after software-controlled switch-off: Press the on key on the back of the device.
- ▶ To switch the device back on again after disconnection from the power supply: Connect the device to the power supply.



### 7.2 User Login or Logout

The user selection is only displayed when at least one user is created.

#### Procedure

- ▶ Press the user selection (1).
- ▶ Select a user, e.g., Administrator.
- ▶ Press the [Login] button.
- ▷ If a password is assigned: The input screen for the password opens.
- ▶ Enter the password and confirm.
- ▶ To log out the active user profile from the device: Press the [Logout] button.
- ▶ If required: Log in a new user.

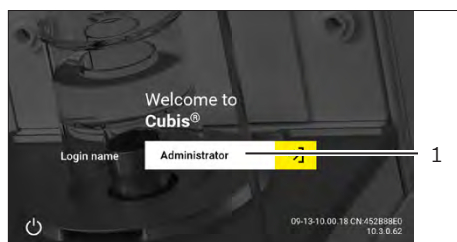

## 7.3 Performing System Settings

Default settings can be adjusted for the device and the applications in order to align with the ambient conditions and individual operating requirements.

The following settings are necessary to operate the device together with connected components:

- Set up the communication of the connected devices
- Set up additional components

The following settings are recommended to set up the device:

- Set the behavior of the isoCAL function.
- If the associated QAPP is activated and the LDAP server is configured: Assign a password.

### Procedure

- ▶ Open the main menu.
- ▶ Press the [Settings] button.
- ▶ To adjust settings: Open the preferred submenu.
- ▶ Select the preferred configuration value.
- ▶ Exit the menu.
- ▷ With some settings, the [Booting device] display is displayed in the operating display and the device restarts.

## 7.4 Using the Help Function

If help texts are available in a menu: The [Help] button is displayed.

### Procedure



- ▶ Press the [Help] button.
- ▶ The help texts are displayed.
- ▶ To navigate through the help text: Swipe the text downwards or upwards.

## 7.5 Activating Applications (QAPPs) and Adding to a Task

### 7.5.1 Activating Applications

Some applications are activated for the device at the factory. Additional applications may be activated in the QAPP Center. These applications can be tested for 30 days free of charge, and after that require a license.

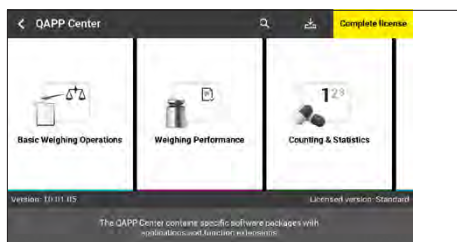

### Procedure

- ▶ Open the task.
- ▶ Press the [QAPP Center] button.
- ▷ An overview of the available QAPP packages is displayed.
- ▶ Select the required QAPP package.
- ▷ A list of the applications contained in the QAPP package is displayed.
- ▶ If the selected QAPP package is to be approved with all the applications it contains:
  - ▶ Press the [License] button.
  - ▷ The input field for the license key is displayed.
  - ▶ If an additional cost is associated with the QAPP package: Enter the license key in the input field and press the [OK] button.
  - ▶ If no additional cost is associated with the QAPP package: Press the [OK] button.
- ▶ If an individual application from the displayed QAPP package is to be activated:
  - ▶ Press the preferred application.
  - ▷ A display opens containing details about the selected application.
  - ▶ Press the [License] button.
  - ▷ The input field for the license key is displayed.
  - ▶ If an additional cost is associated with the application: Enter the license key in the input field and press the [OK] button.
  - ▶ If no additional cost is associated with the application: Press the [OK] button.

## 7.5.2 Adding an Application to a Task

Applications must be added to a task so that they can run.

### Procedure

- ▶ Open the task.
- ▶ Press the [New] button.
- ▷ A list of all activated applications is displayed.
- ▶ To select an application: Press the preferred application.
- ▷ The wizard for creating a new task starts.
- ▶ Follow the wizard's instructions in the operating display.

## 7.6 Switching Off the isoCAL Function

**M**

If the isoCAL function is switched off for a conformity-assessed device: The device can only be used in restricted temperature ranges for legal-for-trade applications (see Chapter "15.3.3 Ambient Temperature for the isoCAL Function", page 46). The isoCAL function **cannot** be switched off for all model versions.

### Procedure

- ▶ In the "isoCal execution module" submenu, for the "isoCAL function" parameter, select the "Off" configuration value.

## 7.7 Adding Weighing and Print Profiles to a Task

To be able to use a weighing or print profile: Add a weighing or print profile to a task. Weighing and print profiles can be configured in the Settings menu.

### Procedure

- ▶ Open the task.
- ▶ Create or edit a task. To do this, start the wizard to create or edit a task and follow the wizard's instructions in the operating display.

## 7.8 Downloading Additional Information

As part of the Cubis® IICUB firmware package on the Sartorius website, additional information is available for the device, e.g., a description of interface protocols, or a set of installation instructions for a website certificate. The information is available as a PDF file, partially in English. The information is stored on the MySartorius website. A Sartorius ID is required to be able to log into MySartorius and call up information. The Sartorius ID can be generated online.

### Procedure

- ▶ Download the "Cubis® CUB Firmware" from the MySartorius website.
- ▶ Find the additional information you require, e.g., the description of interface protocols.

## 7.9 Observing Warm-up Time

After connecting to the power supply, the warm-up time must be observed. This enables the device to reach its required operating temperature and ensures accurate values during weighing processes.



If this relates to a conformity-assessed device: The weight value is marked as **invalid** during the warm-up period.

### Procedure

- ▶ Ensure that the warm-up time is observed (see Chapter "15.6 Warm-up Time to Reach Operating Temperature", page 48).

# 8 Operation

## 8.1 Leveling the Device

Leveling compensates any inclines at the device's installation site. If leveling is necessary: The [Leveling] button is displayed in the weighing display and a message is displayed in the status center.

### Procedure

- ▶ If the weighing display is opened: Press the [Leveling] button.
- ▶ When the status center is displayed: Press the [Level] button.
- ▷ The Leveling Wizard opens.
- ▶ Follow the wizard's instructions.

## 8.2 Calibration and Adjustment

Function	Description
Calibration	The device checks how much the displayed value deviated from the specified setpoint.
Adjustment	The device corrects the deviation to the setpoint.

The device needs to be calibrated and adjusted regularly. Various methods can be selected for this:

- Adjusting with the isoCAL function
- Internal calibration and adjustment
- External adjustment

Only internal adjustment is described below.



External adjustment is **not** possible for conformity-assessed devices in legal metrology.

### Procedure

- ▶ Where one of the following conditions occurs, calibrate and adjust the device using the preferred method:
  - Daily, every time the device is switched on
  - After every leveling
  - After changing the ambient conditions (temperature, humidity, or air pressure)
  - After setting the device up at a new installation site

### 8.2.1 Adjusting With the isoCAL Function

The device can be automatically internally calibrated and adjusted using the isoCAL function.

#### Requirements

- The isoCAL function is configured in the “Safe weighing” menu, e.g., “On, automatic execution”.
- The conditions for triggering and executing the isoCAL function are met (see Chapter “15.11 isoCAL Function”, page 50).

#### Procedure

- ▶ If the isoCAL function is set to automatic start and the isoCAL function is triggered:
  - ▷ The [isoCAL] button flashes in the operating display.
  - ▶ Wait until the isoCAL function is executed.
  - ▷ In the operating display, a time display counts down from 15 seconds to 0.
  - ▷ If **no** load change or **no** operation takes place on the device before the expiration of the time display: The isoCAL function starts.
- ▶ If the isoCAL function is set to manual start and the isoCAL function is triggered:
  - ▷ The [isoCAL] button flashes in the operating display.
  - ▶ Press the [isoCAL] button.
  - ▷ The isoCAL function starts.
- ▷ If the isoCAL function is complete: The device confirms the completion of the calibration and adjustment process with an acoustic signal, and the calibration report is displayed.
- ▶ To output the calibration report via a connector: Press the [Print Memory] button.
- ▶ To close the calibration report and return to the previous display: Press the [OK] button.

### 8.2.2 Internally Calibrating and Adjusting the Device

#### Requirements

The weighing pan is unloaded.

#### Procedure

- ▶ Open the main menu.
- ▶ Press the “Internal adjustment” task.
- ▷ The internal calibration and adjustment function is executed.
- ▷ If automatic leveling is configured: The device levels itself automatically.
- ▷ If the calibration and adjustment function is complete: The device confirms the completion of the calibration and adjustment process with an acoustic signal, and the calibration report is displayed.
- ▶ To output the calibration report via a connector: Press the [Print Memory] button.
- ▶ To close the calibration report and return to the previous display: Press the [OK] button.

## 8.3 Preparing Weighings

The device must be prepared before every weighing.

### Procedure

- ▶ Level the device.
- ▶ Zero the device. To do this, press the [Zero] button.
- ▶ If the device **cannot** be zeroed: Remove the sample to be weighed and re-zero the device.
- ▶ Adjust the device.

## 8.4 Weighing

When weighing chemicals, suitable vessels must be used for the material to be weighed. This makes it possible to prevent damage to the device or its accessories.

### Requirements

The device is leveled and adjusted.

### Procedure

- ▶ Start a task with weighing function.
- ▶ Zero the device. To do this, press the [Zero] button.
- ▶ If below-balance weighing is being carried out: Suspend the sample on the below-balance weighing hook, e.g., with a wire.
- ▶ If using a vessel for the sample:
  - ▶ Place the vessel for the material to be weighed onto the weighing pan.
  - ▶ Press the [Tare] button. This compensates for the weight of the vessel.
  - ▶ Tare the device. To do this, press the [Tare] button.
  - ▶ Place the sample in the vessel or fill the vessel.
- ▶ If **no** vessel is used for the sample: Place the sample on the weighing pan.
- ▶ Once the weight value is displayed in black and the weighing unit is displayed: Read off the measured value.

## 8.5 Running Application (Example)

### 8.5.1 Executing the "Unit change" Function

The "Unit change" function enables switching between the different units and resolutions defined in the weighing profile of the active task. The units and resolutions can be set at the beginning of the weighing process.

### Procedure

- ▶ Start the preferred task.
- ▶ Press the [Unit change] button.
- ▷ All units defined in the weighing profile for the active task are displayed in a list.
- ▷ All resolutions for the weight value defined in the weighing profile for the active task are displayed in a list.
- ▶ Press the preferred unit.
- ▶ To set the resolution for the selected unit: Press the preferred resolution.
- ▶ To confirm the selection and return to the weighing display: Press the [OK] button.
- ▷ The current weight value is displayed in the selected unit and resolution.

## 9 Cleaning and Maintenance

### 9.1 Preparing the Device for Cleaning

#### Procedure

- ▶ If the device is **not** to be cleaned with the Cleaning QAPP: Disconnect the device from the power supply.
- ▶ If an accessory is connected to the device: Disconnect the accessory from the device (see instructions for the accessory).
- ▶ Remove weighing pan and all associated components from the weighing module.

### 9.2 Cleaning the Device

Sartorius recommends cleaning the device at regular intervals, e.g., weekly. There must be **no** foreign substances, e.g., particles, fibers or liquids, in the area of the weighing pan.

To clean the device, you can use Sartorius cleaning utensils or a moistened cloth. The device can be cleaned with the help of the Cleaning QAPP. The Cleaning QAPP contains guided processes for normal and advanced device cleaning. The help texts in the Cleaning QAPP contain notes on valid cleaning agents and cleaning intervals (if cleaning intervals have been set).

#### Procedure

- ▶ **⚠ WARNING** Risk of injury due to electrical current! Protect the power supply unit and the power supply cable from liquids.
- ▶ Only use suitable cleaning agents and cleaning procedures and observe the product information for the cleaning agent used (cleaning agents see Chapter "15.14 Cleaning Agents and Cleaning Procedures", page 52).
- ▶ If the Cleaning QAPP is to be used for cleaning: Open the Cleaning QAPP for cleaning the device and follow the instructions in the operating display.

### 9.3 Recommissioning

#### Procedure

- ▶ Re-insert all components into the device (see Chapter 5.7, page 24).
- ▶ Connect the required accessories (see Chapter 6.4, page 27).
- ▶ If the device was disconnected from the power supply: Re-connect the device to the power supply (see Chapter 6.3, page 27).

## 9.4 Performing a Software Update

A software update can be installed (software package) from a USB mass storage device using one of the device's USB connections. An update can also be carried out from a server via other connectors of the device. The following describes the installation of a USB mass storage device, taken from the Sartorius website.

A software update can extend or change the functionality of the device. Sartorius recommends carrying out software updates:

- Prior to starting the software updates, save the device data to a USB mass storage device.
- If a QAPP Center update is to be carried out in addition: Perform the software update for the device first.

Two files are required for the software update: Firmware file with file ending ".upd", and checksum file with file ending ".upd.md5".

Execution of the software update and troubleshooting during this process are described in the help text "Device maintenance".

### Requirements

- The device is connected to the power supply.
- The logged-in user has administrator rights.

### Procedure

- ▶ Download the software package from the Sartorius website onto the USB mass storage device. To do this, download the "Cubis® III CUB Firmware" file.
- ▶ If this relates to a zip file: Unzip the software package on the USB mass storage device. The files must be saved in the main directory (at root level). The files must **not** be copied into a folder.
- ▶ Insert the USB mass storage device with the software package into the device's USB-A connection.
- ▶ In the "Settings" / "Device maintenance" menu, press the "Update firmware" menu entry.
- ▶ Press the "USB stick" as the connector and select the preferred software version.
- ▷ The software update takes approx. 3 minutes.
- ▷ Once the software update is complete: The software version number is updated in the login display.

## 9.5 Performing a QAPP Center Update

The QAPP Center package can be installed from a USB mass storage device using one of the device's USB connections. An update can also be carried out from a server via other connectors of the device. The following describes the installation of a USB mass storage device, taken from the Sartorius website.

Sartorius recommends the following when carrying out the QAPP Center update:

- Prior to starting the QAPP Center update, save the device data to a USB mass storage device.
- If a software update is also to be carried out: Perform the software update for the device first.

Two files are required for the QAPP Center update: QAPP Center with file ending “.appcenter”, and checksum file with file ending “qappcenter.upd.md5”.

Execution of the QAPP Center update and troubleshooting during this process are described in the help text “Device maintenance”.

### Requirements

- The device is switched on.
- The QAPP Center package is saved on a USB mass storage device or on a server via a connector.

### Procedure

- ▶ Download the QAPP Center package from the Sartorius website onto the USB mass storage device. To do this, download the “Cubis® III CUB Firmware” file.
- ▶ If this relates to a zip file: Unzip the QAPP Center package on the USB mass storage device. The files must be saved in the main directory (at root level). The files must **not** be copied into a folder.
- ▶ Insert the USB mass storage device with the QAPP Center package into one of the device’s USB-A connections.
- ▶ In the “Settings” / “Device maintenance” menu, press the “Install QAPP Center” menu entry.
- ▶ Press “USB stick” as the connector.
- ▶ Press the preferred package.
- ▶ Once the QAPP Center update is complete: Confirm successful installation with the [OK] button.
- ▷ Existing tasks remain unchanged after the QAPP Center update. In the existing tasks, the original QAPP versions are used.
- ▶ In order to use the new QAPP version: Create a new task with the new QAPP version. Existing tasks are **not** automatically adapted via the QAPP Center update.

# 10 Malfunctions

## 10.1 Warning Messages

Warning Message	Malfunction	Cause	Solution	Chapter, Page
Disp.Err.	The value to be output <b>cannot</b> be shown in the operating display.	The data to be displayed is <b>not</b> compatible with the set display format.	Adjust the display settings in the menu, e.g., resolution, unit, decimal places.	
High	The device is overloaded.	The device's maximum weighing capacity has been exceeded.	Reduce the applied weight to below the device's maximum weighing capacity.	15.15, 53
Low	The modulation of the weighing module's weighing converter is too low.	<b>No</b> weighing pan has been placed on the balance.  A previously forgotten weight was removed after starting the device.	Insert the weighing pan into the device and switch the device off and on again.	
Com.Err.	The device is <b>not</b> receiving any weight values.	<b>No</b> communication exists between the control unit and the weighing module.	Wait until the control unit restores the communication with the weighing module.  If the problem reoccurs: Contact Sartorius Service.	17, 58

## 10.2 Troubleshooting

Malfunction	Cause	Solution	Chapter, Page
The operating display is black.	The device is disconnected.	Check whether the power supply unit is connected to the device and the power supply at the installation site.	6.3, 27
	The power supply unit is <b>not</b> connected.	Connect the power supply cable to the power supply.	6.3, 27
The operating display is blank or an error is displayed.	The operating display is <b>not</b> connected.	Check if the connection cable for the operating display is connected to the device.	6.3, 27
The displayed weight value changes constantly.	The device installation site is unstable.	Adjust the parameters in the "Ambient conditions" submenu.	7.3, 29
		Change the installation site.	5.2, 21
	A foreign object is positioned between the weighing pan and the housing.	Remove the foreign object.	
The weight readout displayed by the device is obviously wrong.	The device has <b>not</b> been adjusted.	Adjust the device.	8.2, 32
	The device was <b>not</b> tared before weighing.	Tare the device.	
An accessory device connected to the USB port is <b>not</b> working.	The connection to the device has been interrupted.	Switch the device off and on again.	
The operating display is red.	The connection to the device has been interrupted.	Switch the device off and on again.	

## 10.3 Operating Issues

Malfunction	Cause	Solution	Chapter, Page
Password forgotten.	A user has forgotten the password.	Contact the administrator to delete or reset the password.	
	The administrator has forgotten the password.	Contact Sartorius Service to delete or reset the password.	17, 58

# 11 Decommissioning

## 11.1 Decommissioning the Device

### Procedure

- ▶ Disconnect the device from the power supply. To do this, disconnect the power supply cable from the wall outlet.
- ▶ Disconnect all cables and accessories from the device connections.
- ▶ Place all caps and attachment hoods onto the corresponding connections.
- ▶ If an accessory is connected to the device: Disconnect the accessory from the device (see instructions for the accessory).
- ▶ If below-balance weighing has been set up:
  - ▶ Unscrew the below-balance weighing hook from the thread (1).
  - ▶ Insert the below-balance weighing hook back into its retainer on the underside of the weighing module.
  - ▶ Re-insert the cover (2) of the below-balance weighing equipment.
- ▶ Clean the device (see Chapter "9.2 Cleaning the Device", page 36).

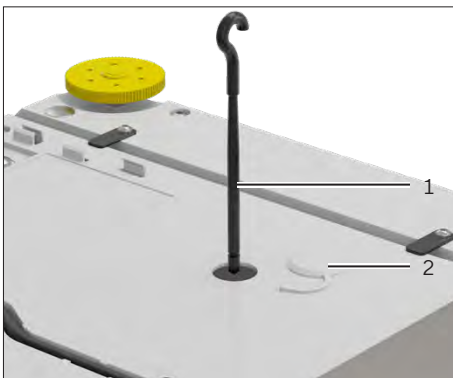

# 12 Transport

## 12.1 Transporting the Device

### Requirements

- The device has been decommissioned.
- The operating display is secured to the device.

### Procedure

- ▶ **⚠ CAUTION** Risk of injury when lifting or transporting!
  - ▶ Disconnect the device from all connections at the installation site.
  - ▶ Use both hands when transporting the device and setting it down. To do this, reach sideways under the device with both hands in the rear part of the device.
- ▶ For transporting over longer distances, use a trolley with soft mats. The operating display must be positioned entirely on the base.
- ▶ When lifting and transporting, ensure that **no** personnel or objects are in the way.



# 13 Storage and Shipping

## 13.1 Storing

### Procedure

- ▶ Decommission the device.
- ▶ Ensure that the control unit is attached to the device.
  - ▶ If required: Attach the control unit to the device.
- ▶ Store the device according to the ambient conditions (see Chapter “15.2 Ambient Conditions During Storage and Transport”, page 44).

## 13.2 Returning the Device and Parts

Defective devices or parts can be returned to Sartorius. Returned devices must be clean and packed in their original packaging.

Transport damage as well as measures for subsequent cleaning and disinfection of the device or parts by Sartorius shall be charged to sender.

Devices contaminated with hazardous materials, e.g., harmful biological or chemical substances, will **not** be accepted for repair or disposal.

### Procedure

- ▶ Decommission the device.
- ▶ Ensure that the control unit is attached to the device.
  - ▶ If required: Attach the control unit to the device.
- ▶ Contact Sartorius Service for instructions on how to return devices or parts.
- ▶ Pack the device and its parts in their original packaging for return.

# 14 Disposal

## 14.1 Disposing of the Device and Parts

The device and the device accessories must be disposed of properly by disposal facilities.

Two lithium cell batteries, type CR2032, are installed inside the device. Batteries must be disposed of properly by disposal facilities.

Many of the packaging materials are recyclable to promote sustainability and to contribute to reducing global waste volumes.

### Procedure

- ▶ Dispose of the device in accordance with local government regulations. Inform the disposal facility that there are two lithium cell batteries, type CR2032, installed inside the device.
- ▶ Dispose of the packaging in accordance with local government regulations.

# 15 Technical Data

## 15.1 Dimensions and Weights

	Unit	Value
Dimensions		
Device dimensions (L x W x H)	mm	402 x 240 x 95
Device dimensions (L x W x H) with control unit removed	mm	270 x 240 x 95
With control unit removed: Max. distance between device and control unit	cm	15
Weighing pan size (L x W)	mm	206 x 206
Weight	kg	6.0

## 15.2 Ambient Conditions During Storage and Transport

	Unit	Value
Temperature		
During storage and transport	°C	-20 - +60

## 15.3 Installation Conditions

### 15.3.1 Installation Site

	Unit	Value
Height above sea level, maximum	m	3000
<b>No</b> potentially explosive atmospheres		
Suitable for protection class		
Protection class of the device, according to EN 60529-1		IP 54
Protection class of the power supply unit, according to DIN EN 60529		IP 54
Access to operation-relevant parts is guaranteed		
Additional properties		
<b>No</b> heat from heating systems or direct sunlight		
<b>No</b> direct drafts from open windows, AC systems, or doors		
<b>No</b> vibrations		
<b>No</b> "heavy traffic" areas (personnel)		
<b>No</b> electromagnetic fields or electromagnetic radiation, e.g., from radio equipment		
<b>No</b> condensation		
<b>No</b> dry air		

### 15.3.2 Ambient Conditions at the Installation Site

	Unit	Value
Temperature		
In operation	°C	+5 – +40
In operation, with conformity-assessed devices, as per specifications on the device ID label		
Relative humidity, in operation		
At temperatures up to 31 °C, maximum	%	80
Then linear decrease from 80 % at 31 °C to 50 % at 40 °C		
In operation, with conformity-assessed devices, as per specifications on the device ID label		
Air pressure, minimum	mbar	600

### 15.3.3 Ambient Temperature for the isoCAL Function

CUB14202S   CUB10202S		
	Unit	Value
Scope of application as per Directive 2014/31/EU		
With isoCAL function	°C	+10 - +30
Without isoCAL function	°C	+17 - +27

CUB8202S   CUB6202S   CUB6202P   CUB4202S   CUB2202S   CUB1202S   CUB12201S   CUB8201S   CUB5201S		
	Unit	Value
Scope of application as per Directive 2014/31/EU		
With isoCAL function	°C	+10 - +30
Without isoCAL function	°C	+10 - +30

### 15.4 Acclimatization Before Power Supply

	Unit	Value
Time period between unpacking and connecting to a power supply	h	2

## 15.5 Electrical Data

### 15.5.1 Power Supply

	Unit	Value
Power supply only permitted via the power supply cable and power supply unit supplied by Sartorius		
Sartorius power supply unit, YEPS03-15V0		
Primary (power supply unit)		
AC voltage	V	100 - 240 ( $\pm 10\%$ )
Frequency	Hz	50 - 60 ( $\pm 5\%$ )
Current consumption, maximum	A	1.0
Secondary (device)		
DC voltage	V	14.25 - 15.75
Current consumption, maximum	A	2.0
Power consumption, typical	W	5.0
Device fuses		
Quantity		1
Type: Electronic		
Power supply unit fuses		
Quantity		1
Type: Electronic		
Protection class, according to IEC 62368-1		
Device		I
Power supply unit		I
Overvoltage category according to IEC 61010-1		
Device		II
Power supply unit		II

### 15.5.2 Safety of Electrical Equipment

Safety provisions according to IEC 61010-1 Safety requirements for electrical equipment for measurement, control, and laboratory use – Part 1: General requirements

### 15.5.3 Electromagnetic Compatibility

Electromagnetic compatibility according to DIN EN/IEC 61326-1: Electrical equipment for measurement, control and laboratory use – EMC requirements – Part 1: General requirements (DIN EN/IEC 61326-1)

Interference immunity: Suitable for use in industrial areas (Table 2 of the standard)

Transient emissions: Class B: Suitable for use in residential areas and areas that are directly connected to a low voltage network that (also) supplies residential buildings

### 15.6 Warm-up Time to Reach Operating Temperature

		CUB14202S   CUB10202S	CUB8202S   CUB6202S   CUB6202P   CUB4202S   CUB2202S   CUB1202S   CUB12201S   CUB8201S   CUB5201S
	Unit	Value	Value
Time period between switching the device on and carrying out weighing tasks	h	0.5	0

## 15.7 Interfaces

### 15.7.1 COM-RS232 Interface

Type of interface: Serial interface

Interface operation: Full duplex

Level: RS232

Connection type: D-sub connector, 9-pin

#### Pin assignment

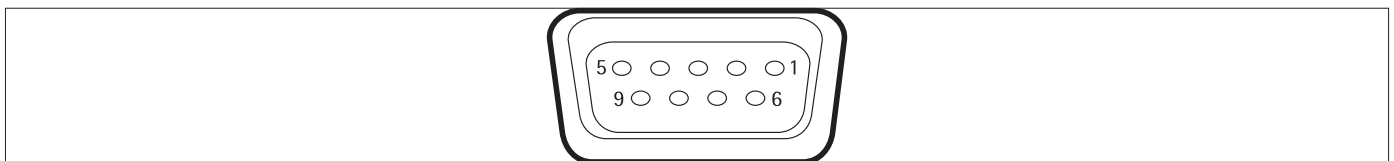

Fig.8: Pin 1 – 9

Pin	Description
1, 4, 6, 9	Not used
2	Data output (T x D)
3	Data input (R x D)
5	Internal ground
7	Clear to Send (CTS)
8	Request to Send (RTS)

### 15.7.2 Specifications for the USB-A Interface

Communication: USB host (Master)

Connectable devices: Sartorius printers, USB memory sticks, USB barcode scanners, USB keyboards

### 15.7.3 Specifications for the USB-B Interface

Communication: USB device (Slave)

Type of interface: Virtual serial interface (virtual COM-port, VCP) and “PC-Direct” communication

## 15.8 Data Storage Device

	Value
Maximum number of entities	500000

## 15.9 Integrated Clock

	Unit	Value
Maximum deviation per month (RTC)	s	30

## 15.10 Backup Battery

	Unit	Value
Lithium battery, type CR2032		
Service life at room temperature, minimum	Years	10

## 15.11 isoCAL Function

### 15.11.1 Models CUB14202S | CUB10202S

	Unit	Value
isoCAL is triggered by the following criteria:		
In the event of a temperature change	K	1.5
After a time interval	h	6
After successful leveling		

### 15.11.2 Models CUB8202S | CUB6202S | CUB6202P | CUB4202S | CUB2202S | CUB1202S

	Unit	Value
isoCAL is triggered by the following criteria:		
In the event of a temperature change	K	2
After a time interval	h	12
After successful leveling		

### 15.11.3 Models CUB12201S | CUB8201S | CUB5201S

	Unit	Value
isoCAL is triggered by the following criteria:		
In the event of a temperature change	K	4
After a time interval	h	12
After successful leveling		

### 15.12 Recommended Adjustment Weight

		CUB14202S	CUB10202S	CUB8202S	CUB6202S
	Unit	Value	Value	Value	Value
External test weight	g	14000	10000	7000	5000
Recommended accuracy class		E2	E2	E2	E2

		CUB6202P	CUB4202S	CUB2202S	CUB1202S
	Unit	Value	Value	Value	Value
External test weight	g	5000	3000	1500	700
Recommended accuracy class		E2	E2	E2	E2

		CUB12201S	CUB8201S	CUB5201S
	Unit	Value	Value	Value
External test weight	g	12000	8000	5000
Recommended accuracy class		F1	F1	F1

### 15.13 Materials

#### Housing

Die-cast aluminum

Plastic PBT

Float glass Optiwhite and stainless steel 1.4401 / 1.4404

Handles PA

Bars aluminum

#### Control unit

Aluminum, painted

Operating display: Plastic PA12 | float glass

Weighing pan: Titanium

## 15.14 Cleaning Agents and Cleaning Procedures

### 15.14.1 Approved Cleaning Agents

Device components	Cleaning agents and concentration					
	Ethanol, 70 %	Isopropanol, 70 %	Citric acid, 10 %	Diluted hy- drogen per- oxide, 3.5 %	Sodium hy- droxide, 32 %	Ecolab Klercide™ Sporicidal Chlorine Thiosulfate
Components in the weighing compartment						
Weighing pan	x	x	x	x	xx	x
Shield disk	x	x	x	x	xx	x
Base plate of weighing compartment (removable)	x	x	x	x	xx	x
Rear wall of weighing compartment	xx	x	x	x	x	x
Weighing compartment support (holds the base plate of the weighing compartment)	x	x	x	x	x	x
Control unit	x	x	x	x	x	x
Back of the device						
Plastic surfaces	x	xx	x	x	x	x
Cooling element	x	xx	x	x	x	x

x Suitable

xx Suitable, may affect visual appearance of the device, does **not** impact mechanical stability

- **Not** suitable

### 15.14.2 Approved Cleaning Procedures

Wiping the device surfaces with a lightly moistened cleaning cloth		
Spraying the device surfaces with cleaning agents, contact time	Min	5 - 10
<b>No autoclaving</b>		

## 15.15 Metrological Data

### 15.15.1 Models CUB14202S | CUB10202S | CUB8202S

		CUB14202S	CUB10202S	CUB8202S
	Unit	Value	Value	Value
Scale interval (d)	mg	10	10	10
Maximum capacity (Max)	g	14200	10200	8200
Repeatability at 5 % load				
Standard deviation of the load values, tolerance	mg	10	7	7
Standard deviation of the load values, typical value	mg	4	4	4
Repeatability at approx. maximum capacity				
Standard deviation of the load values, tolerance	mg	10	7	7
Standard deviation of the load values, typical value	mg	5	5	4
Linearity deviation				
Tolerance	mg	30	20	20
Typical value	mg	10	6	6
Deviation when load is off-center, positions according to OIML R76				
Test weight	g	5000	5000	5000
Tolerance	mg	20	20	30
Typical value	mg	10	10	10
Sensitivity drift between +10 °C and +30 °C	ppm/K	1.5	1.5	2
Tare-maximum capacity: Less than 100 % of maximum capacity				
Accuracy class, according to Directive 2014/31/EU		I	I	II
Verification scale interval (e), according to Directive 2014/31/EU	g	0.1	0.1	0.1
Minimum load (Min), according to Directive 2014/31/EU	g	1	1	0.5
Minimum initial weight according to USP (United States Pharmacopeia), Chap. 41				
Optimum minimum initial weight	g	8.2	8.2	8.2
Typical minimum initial weight	g	8.2	8.2	8.2
Typical stabilization time	s	0.8	0.8	1
Typical measurement time	s	1.5	1.5	1.5

## 15.15.2 Models CUB6202S | CUB6202P | CUB4202S | CUB2202S

		CUB6202S	CUB6202P	CUB4202S	CUB2202S
	Unit	Value	Value	Value	Value
Scale interval (d)	mg	10	10 20 50	10	10
Maximum capacity (Max)	g	6200	1500 3000 6200	4200	2200
Repeatability at 5 % load					
Standard deviation of the load values, tolerance	mg	7	7	7	7
Standard deviation of the load values, typical value	mg	4	4	4	4
Repeatability at approx. maximum capacity					
Standard deviation of the load values, tolerance	mg	7	40	7	7
Standard deviation of the load values, typical value	mg	4	15	4	4
Linearity deviation					
Tolerance	mg	20	50	20	20
Typical value	mg	6	20	6	6
Deviation when load is off-center, positions according to OIML R76					
Test weight	g	2000	2000	2000	1000
Tolerance	mg	20	30	30	20
Typical value	mg	10	30	10	10
Sensitivity drift between +10 °C and +30 °C	ppm/K	2	2	2	2
Tare-maximum capacity: Less than 100 % of maximum capacity					
Accuracy class, according to Directive 2014/31/EU		II	II	II	II
Verification scale interval (e), according to Directive 2014/31/EU	g	0.1	0.1	0.1	0.1
Minimum load (Min), according to Directive 2014/31/EU	g	0.5	0.5	0.5	0.5
Minimum initial weight according to USP (United States Pharmacopeia), Chap. 41					
Optimum minimum initial weight	g	8.2	8.2	8.2	8.2
Typical minimum initial weight	g	8.2	8.2	8.2	8.2
Typical stabilization time	s	1	1	1	0.8
Typical measurement time	s	1.5	1.5	1	1

### 15.15.3 Models CUB1202S | CUB12201S | CUB8201S | CUB5201S

		CUB1202S	CUB12201S	CUB8201S	CUB5201S
	Unit	Value	Value	Value	Value
Scale interval (d)	mg	10	100	100	100
Maximum capacity (Max)	g	1200	12200	8200	5200
Repeatability at 5 % load					
Standard deviation of the load values, tolerance	mg	7	50	50	50
Standard deviation of the load values, typical value	mg	4	20	20	20
Repeatability at approx. maximum capacity					
Standard deviation of the load values, tolerance	mg	7	50	50	50
Standard deviation of the load values, typical value	mg	4	20	20	20
Linearity deviation					
Tolerance	mg	20	100	100	100
Typical value	mg	6	30	30	20
Deviation when load is off-center, positions according to OIML R76					
Test weight	g	500	5000	5000	2000
Tolerance	mg	20	200	200	200
Typical value	mg	10	100	100	100
Sensitivity drift between +10 °C and +30 °C	ppm/K	2	4	4	4
Tare-maximum capacity: Less than 100 % of maximum capacity					
Accuracy class, according to Directive 2014/31/EU		II	II	II	II
Verification scale interval (e), according to Directive 2014/31/EU	g	0.1	1	1	1
Minimum load (Min), according to Directive 2014/31/EU	g	0.5	5	5	5
Minimum initial weight according to USP (United States Pharmacopeia), Chap. 41					
Optimum minimum initial weight	g	8.2	82	82	82
Typical minimum initial weight	g	8.2	82	82	82
Typical stabilization time	s	0.8	0.8	0.8	0.8
Typical measurement time	s	1	1	1	1

# 16 Accessories

## 16.1 Accessories

This table contains a selection of the accessories that can be ordered. For information on other products, contact Sartorius.

Item	Quantity	Order Number
Printers and communication		
Thermal transfer   direct thermal printer for GLP   GMP printouts on continuous paper and labels	1	YDP30
Thermal transfer   direct thermal network printer with Ethernet connection for GLP   GMP printouts on continuous paper and labels	1	YDP30-NET
Wireless nano USB adapter for company network or independent Wi-Fi network, e.g., operation with a Sartorius network printer YDP30-NET (only for Europe)	1	YWLAN01MS
USB-RFID reader	1	YRFID01
Wireless nano router, e.g., for Sartorius network printer YDP30-NET for operation in an independent Wi-Fi network (only for Europe)	1	YWLAN02MS
Connection cable, 3 m, for separate installation of control unit and weighing module	1	YCC01-CUB-2
Installation of connection cable, 3 m, for separate installation of control unit and weighing module	1	VF4016
RS232C connection cable, 9-pin, 3 m, for connection to a PC with 9-pin COM interface	1	VF4761
USB connection cable 3 m, USB-B to USB-A, for connecting the balance to a computer	1	69MS0099
USB QR barcode scanner	1	YBR05
Foot switch for draft shield, tare, print	1	YFS02
Displays and input   output elements		
Motion sensor for triggering a maximum of 4 functions via gesture control, selection via menu	1	YHS02MS
Special applications		
Grid pan for models with a scale interval of 10 mg or 100 mg for weighing in laboratory hoods, safety barriers, and workbenches, reduced wind attack surface of the weighing pan, replaces standard weighing pan	1	YWP07MS

Item	Quantity	Order Number
Weighing tables		
Weighing table made from synthetic stone, with vibration dampening	1	YWT03
Weighing table made from wood and synthetic stone	1	YWT09
Wall console	1	YWT04
Weighing accessories		
Weighing scoop made from chrome-nickel steel, L 90 mm × W 32 mm × H 8 mm	1	641214
Stand for weighing modules with scale intervals of 10 mg   100 mg for raising the control units	1	YDH03CUB

## 17 Sartorius Service

Sartorius Service is available for queries regarding the device. Visit the Sartorius website for information about the service addresses, services provided, or to contact a local representative.

For inquiries about the system or when contacting Sartorius Service in the event of a malfunction, keep the device information close at hand, e.g., serial number, hardware, firmware, configuration, to pass it on to Sartorius Service. To do this, refer to the information on the manufacturer's ID label and in the "General device Information" menu.

## 18 Trademark Information

Ecolab Klercide™ is a registered trademark of Ecolab Europe GmbH.

## 19 Conformity

### 19.1 EU Declaration of Conformity

The attached Declaration of Conformity hereby confirms compliance of the device with the directives cited.

**M**

The Declaration of Conformity supplied with the balance is for conformity-assessed (verified) balances for use in the EEA. Keep it in a safe place.