

# Chemistry vacuum system

## MZ 2C NT +AK+EK

[www.imlab.eu](http://www.imlab.eu)



### Product description

This chemistry vacuum system has a wide range of applications like evacuation, evaporation and pumping of gases and vapors in chemical, biological and pharmaceutical laboratories. Typical applications are rotary evaporators, vacuum concentrators and vacuum drying ovens. The separator at the inlet (AK), made of glass with protective coating, retains particles and liquid droplets. The waste vapor condenser at the outlet (EK) is highly efficient and compact. The condenser enables near-100-percent solvent recovery, efficient recycling, and active protection of the environment.

### Performance features

- outstanding chemical resistance and superior vapor tolerance
- high performance even at low vacuum levels
- optimized vacuum even with gas ballast for condensate purge
- whisper quiet and very low vibration
- excellent environmental friendliness due to efficient solvent recovery

## Ordering data

Product name	Nominal mains voltage   mains frequency	Plug type	Articleno.
MZ 2C NT +AK+EK	230 V   50-60 Hz	CEE	20732600
MZ 2C NT +AK+EK	230 V   50-60 Hz	CH	20732601
MZ 2C NT +AK+EK	230 V   50-60 Hz	UK, IN	20732602
MZ 2C NT +AK+EK	100-115 V   50-60 Hz 120 V   60 Hz	US	20732603
MZ 2C NT +AK+EK	230 V   50-60 Hz	CN	20732607

## Items supplied

Pumping unit completely mounted, ready for use, with manual.

## Accessories

- Silencer with hose 5cm DN 8-10mm (20636588)
- Adjustable elbow DN 10/8 mm (20637873)
- Vacuum tubing transparent DN 8 mm (20686061)
- Set of diaphragms and valves MZ 2C NT / MZ 2C NT VARIO / PC 3002 (20696869)
- Set of diaphragms and valves MZ 2C NT / MZ 2C NT VARIO / PC 3002 (20696869)

## Technical data

Max. pumping speed 50 Hz (m <sup>3</sup> /h)	2 m <sup>3</sup> /h
Max. pumping speed 60 Hz (cfm)	1.4 cfm
Ultimate vacuum	7 mbar / 5 torr
Ultimate vacuum with gas ballast	12 mbar / 9 torr
Number of heads	2
Number of stages	2
Permissible ambient temperature range (operation)	10 - 40 °C
Permissible ambient temperature range (storage)	-10 - 60 °C
Max. outlet pressure (abs.)	1.1 bar
Inlet connection	Hose nozzle DN 8-10 mm
Outlet connection	Hose nozzle DN 8-10 mm
Coolant connection	2 x hose nozzle DN 6-8 mm
Rated motor power	0.18 kW
Rated speed 50/60 Hz	1500/1800 min <sup>-1</sup>
Protection class IEC 60529	IP 40
Dimensions (L x W x H)	326 mm x 243 mm x 402 mm
Weight	14.2 kg
Noise (sound pressure level) in dBA at 50 Hz or 1500 rpm/62% (VARIO)/1500 rpm (VARIO-SP)/12500 Upm (VACUU·PURE®)	45 dBA
ATEX conformity	II 3/- G Ex h IIC T3 Gc X Internal Atm. only
NRTL certification	Yes

Pumping speed graph at 50 Hz

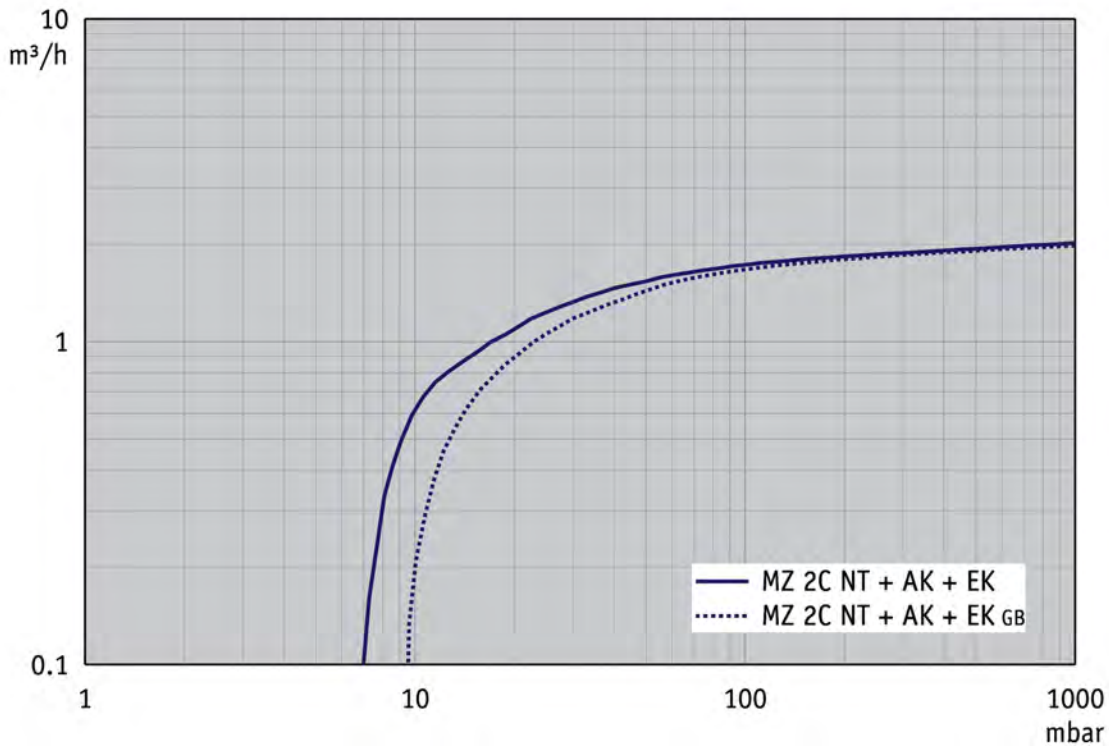

Pump down graph at 50 Hz (10 l volume)

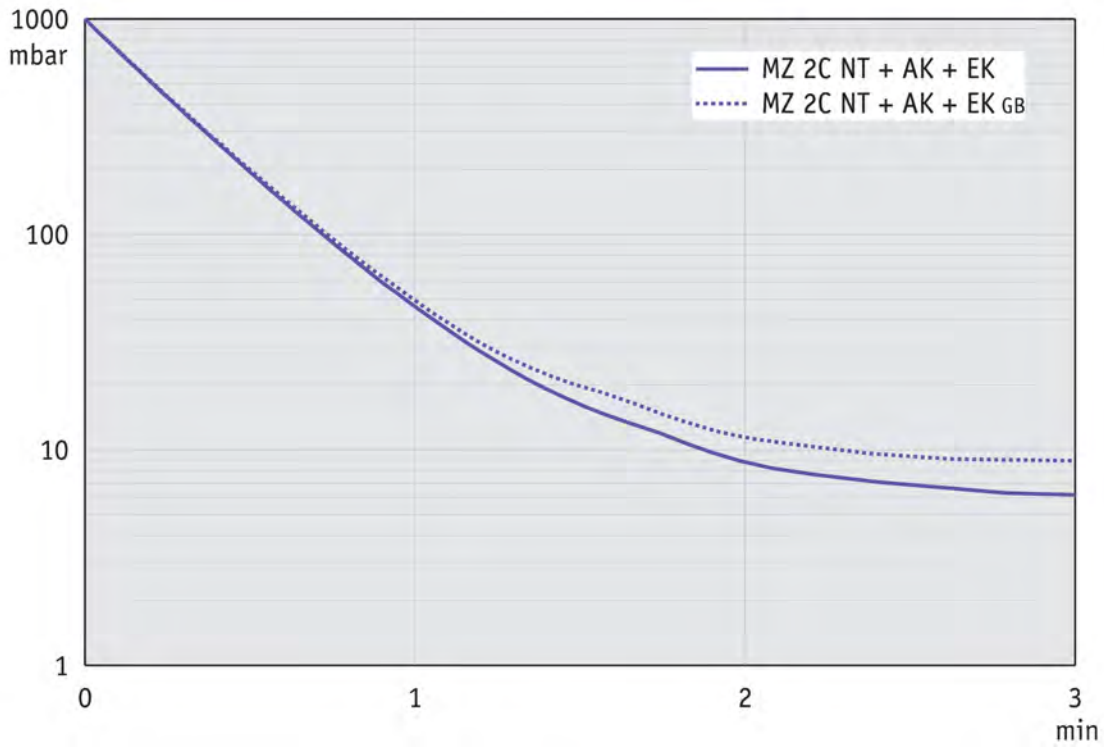

Pumping speed graph at 60 Hz

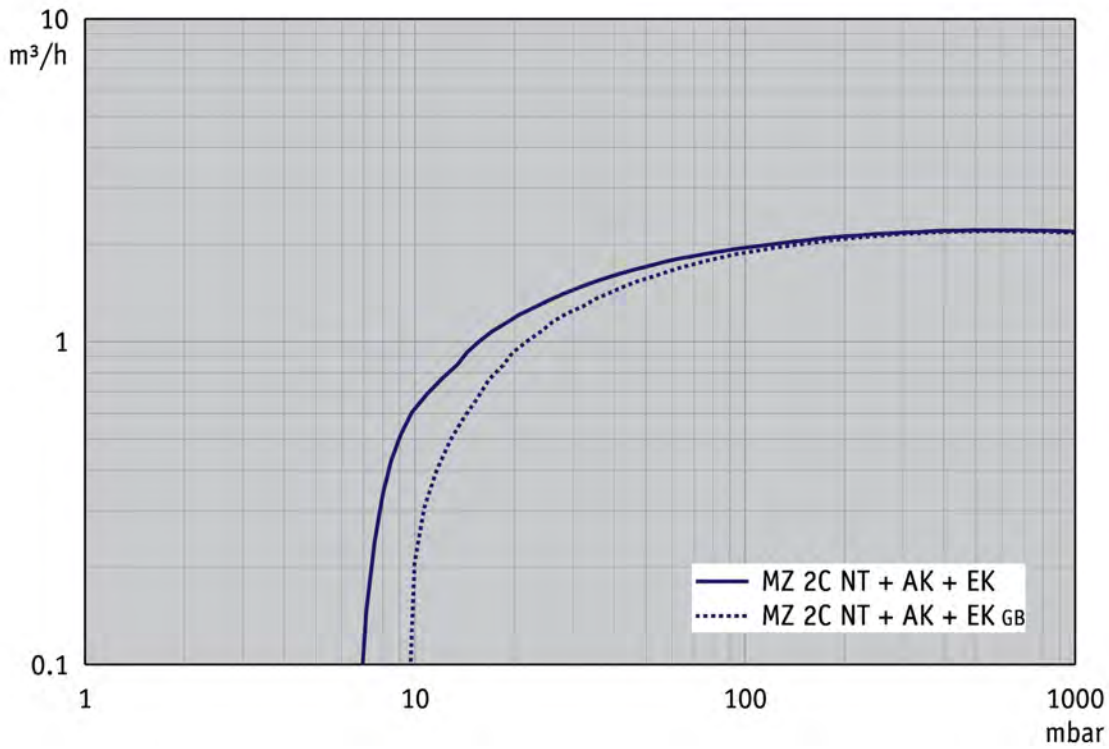

Pump down graph at 60 Hz (10 l volume)

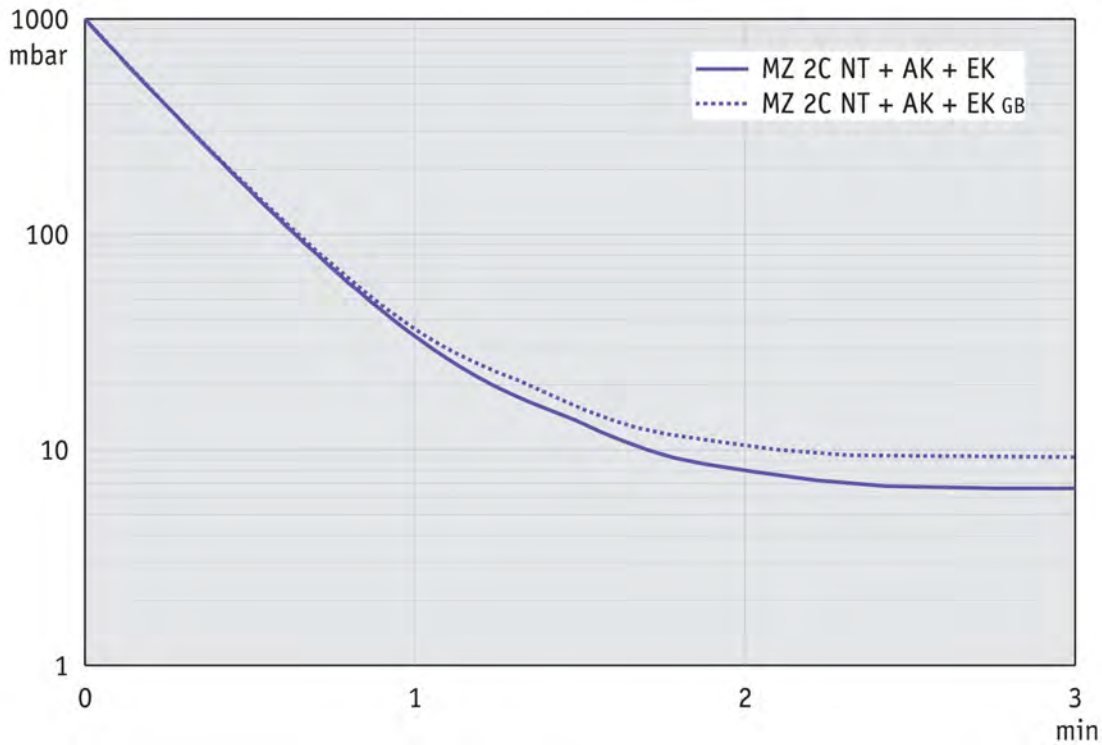

Dimension sheet

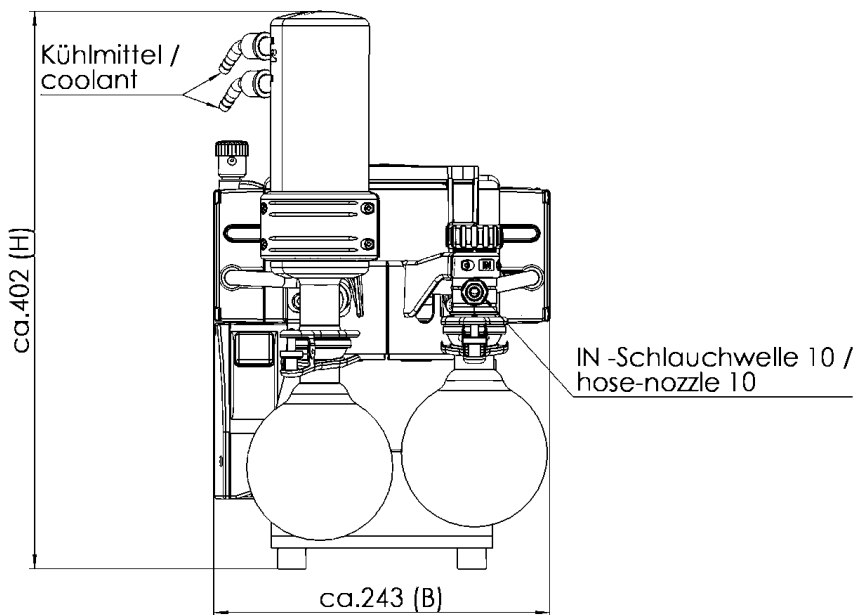

Alle Maße / all dimensions (mm)  
Gewicht / weight: 14,2 kg

EX - Schlauchwelle 10 /  
hose-nozzle 10

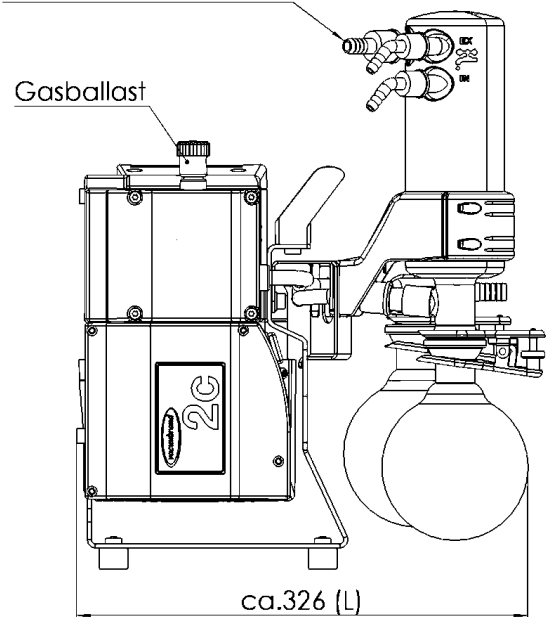

VACUUBRAND MZ 2C NT AK+EK  
Version 2009/03/23

VACUUBRAND is part of the Brand group, a manufacturer of high-quality and innovative laboratory equipment and vacuum technology with a global team of approx. 1,000 employees.

With highly motivated and qualified employees, we manufacture the world's most comprehensive product family for vacuum generation, measurement and control for the rough and fine vacuum range in the laboratory.

**All with one goal:**

Enabling our customers to run reliable, safe and efficient processes. This is why we commit ourselves to continuous innovation, first-class performance, and outstanding quality.

Engineering excellence is central to our ability to deliver products and solutions renowned for their quality, durability, and reliability. Innovative technology, high quality materials and extensive testing deliver unmatched performance - engineered and manufactured in Germany.

Together with you, our experts will find the best solution for your application and provide you with first-class service along the way.